

Curriculum and Detailed Syllabi

For

B.E. Mechatronics

2014 Regulations



Thiagarajar College of Engineering

(A Govt. Aided, Autonomous Institution, Affiliated to Anna University)

Madurai – 625 015, Tamil Nadu

Table of Contents		
Topic		Page Number
<i>Vision and Mission</i>		<i>i</i>
<i>PEO, PO, PSO</i>		<i>ii</i>
<i>Scheduling of Courses</i>		<i>v</i>
<i>Categorization of Courses</i>		<i>vi</i>
<i>Course of Study and Scheme of Evaluation</i>		<i>xii</i>
First Semester		
14MA110	Engineering Mathematics-I	2
14PH120	Physics	6
14CH130	Chemistry	10
14EG141	English	14
14ES150	Basics of Civil and Mechanical Engineering	18
14ES160	Basics of Electrical and Electronics Engineering	24
14ME170	Engineering Graphics	30
14PH180	Physics Laboratory	36
14CH190	Chemistry Laboratory	37
Second Semester		
14MT210	Engineering Mathematics-II	39
14MT220	Free Body Mechanics	45
14MT230	Electrical Machines	54
14MT240	Materials for Mechanical and Electronic Systems	60
14MT250	Environmental Science and Engineering	65
14MT270	Analog and Digital Devices (TCP)	71
14MT280	Electrical Machines Lab	78
14MT290	Workshop	79
Third Semester		
14MT310	Fourier Analysis and Partial Differential Equations	81
14MT320	Kinematics and Dynamics of Machinery	88
14MT330	Sensors and PLC	95
14MT340	Thermal Engineering and Fluid Mechanics	100
14MT350	Manufacturing Processes	105
14MT370	Problem solving using Computer	112
14MT380	Thermal Engineering Lab	117

Table of Contents		
Topic		Page Number
14MT390	Manufacturing Processes Lab	119
Fourth Semester		
14MT410	Linear algebra and Numerical Methods	121
14MT420	Engineering Design	127
14MT430	Analog and Digital circuits Design	130
14MT440	Metrology and Measurements	136
14MT450	Fluid Power Automation	142
14MT470	Professional Communication	147
14MT480	Automation Lab	150
14MT490	Metrology and Measurements Lab	152
14MT4C1	Capstone Course – I	154
Fifth Semester		
14MT510	Optimization Techniques	159
14MT520	Control System	165
14MT530	Power Electronics and drives	170
14MT540	CNC Technology	175
14MT570	Microcontroller	180
14MT580	CAD/CAM Lab	185
14MT590	Analog and Digital Circuit Design Lab	187
Sixth Semester		
14MT610	Accounting and finance	189
14MT620	Industrial Robotics	196
14MT630	Mechatronics system Design	201
14MT640	Digital Signal Processing	207
14MT680	Dynamics and Control Lab	212
14MT690	Robotics Lab	214
Seventh Semester		
14MT710	Project Management	216
14MT720	Unmanned Aerial Vehicles	222
14MT770	System Integration (Theory Cum Practical)	227
14MT7C0	Capstone Course – II	233
Program Specific Electives (PE)		

Table of Contents		
Topic		Page Number
14MTPA0	Machine Vision System	236
14MTPB0	Micro Electro Mechanical Systems	242
14MTPC0	Additive Manufacturing	248
14MTPD0	Integrated Product Development	252
14MTPE0	VERILOG HDL	257
14MTPF0	Total Quality Management	261
14MTPG0	Smart materials for Mechatronics	267
14MTPH0	Embedded system	272
14MTPJ0	Programming for Robotics system	276
14MTPK0	Industrial Internet of Things	280
14MTPM0	Industrial Communication Networks	285
14MTPN0	Automotive Mechatronics	290
14MTPP0	Artificial Intelligence	295
14MTPQ0	Modern Control Systems	299
14MTPR0	Mechanical and Thermal Packaging of Electronics	304
14MTPT0	Data Analytics	310
14MTPU0	Mobile Robotics	314
14MTPW0	Virtual Instrumentation	320
14MTPY0	Design of Machine Elements	326
14MTRA0	Selection and Integration of sensors	332
General Electives		
14MTGA0	Industrial Automation	337
14MTGB0	Mechatronics	343
14MTGC0	Total Quality Management	349
14MTGD0	Sensors	355
Industry Supported Courses		
14MT1A0	Elevator System Design	359
14MT1B0	Motion Logic Drives and Control	364
14MT1C0	Mobile Hydraulics	368
Revised Course(s)		
14MT691	Robotics Laboratory	372
Revised CO-PO Mapping		374



Thiagarajar College of Engineering

– Where quality and ethics matter

Vision Statement:

“World class quality technical education with strong ethical values”

Mission Statement:

We at TCE shall strive continuously,

- Academic excellence in Science, Engineering and Technology through dedication to duty, commitment to research, innovation in learning and faith in human values
- Enable the students to develop into outstanding professionals with high ethical standards capable of creating, developing and managing global engineering enterprises
- Fulfil expectations of the society and industry by equipping students with state of art technology resources for developing sustainable solutions
- Achieve these through team efforts making Thiagarajar College of Engineering the socially diligent trend setter in technical education

DEPARTMENT OF MECHATRONICS ENGINEERING

Vision:

“Be a globally renowned school of engineering in Mechatronics”

Mission:

As a department, we are committed to

- Develop ethical and competent engineers by synergizing world class teaching, learning and research
- Establish state-of-art laboratories and to provide consultancy services to fulfil the expectations of industry and needs of the society
- Inculcate entrepreneurial qualities for creating, developing and managing global engineering ventures
- Motivate the students to pursue higher studies and research

Programme Educational Objectives (PEOs) of B.E. (Mechatronics)

PEO 1: The programme will prepare graduates to synergistically integrate mechanical engineering with electronic and intelligent computer control in the design and manufacture of industrial products and processes

PEO 2: The programme will prepare graduates with strong team skills to involve in integrated product development.

PEO 3: The programme will prepare graduates with an understanding of their ethical and social responsibility.

Programme Outcomes (POs) of B.E. (Mechatronics)

PO1	Engineering knowledge	Apply the knowledge of mathematics, science, engineering fundamentals, and an engineering specialization to the solution of complex engineering problems
PO2	Problem analysis	Identify, formulate, research literature, and analyses Complex engineering problems reaching substantiated conclusions using first principles of mathematics, natural sciences, and engineering sciences
PO3	Design/development of solutions	Design solutions for complex engineering problems and design system components or processes that meet the specified needs with appropriate consideration for the public health and safety, and the cultural, societal, and environmental considerations
PO4	Conduct investigations of complex problems	Use research-based knowledge and research methods including design of experiments, analysis and interpretation of data, and synthesis of the information to provide valid conclusions
PO5	Modern tool usage	Create, select, and apply appropriate techniques, resources, and modern engineering and IT tools including prediction and modelling to complex engineering activities with an understanding of the limitations
PO6	The engineer and society	Apply reasoning informed by the contextual knowledge to assess societal, health, safety, legal, and cultural issues and the consequent responsibilities relevant to the professional engineering practice
PO7	Environment and sustainability	Understand the impact of the professional engineering solutions in societal and environmental contexts, and demonstrate the knowledge of, and need for sustainable development
PO8	Ethics	Apply ethical principles and commit to professional ethics and responsibilities and norms of the engineering practice
PO9	Individual and team work	Function effectively as an individual, and as a member or leader in diverse teams, and in multidisciplinary settings
PO10	Communication	Communicate effectively on complex engineering activities with the engineering community and with society at large, such as, being able to comprehend and write effective reports and design documentation, make effective presentations, and give and receive clear instructions
PO11	Project management and finance	Demonstrate knowledge and understanding of the engineering and management principles and apply these to one's own work, as a member and leader in a team, to manage projects and in multidisciplinary environments
PO12	Life-long learning	Recognize the need for, and have the preparation and ability to engage in independent and life-long learning in the broadest context of technological change

PEO – PO Matrix

POs PEOs	PO1	PO2	PO3	PO4	PO5	PO6	PO7	PO8	PO9	PO10	PO11	PO12
PEO1	S	S	S	S	S	M	S	M	L	M	M	M
PEO2	S	S	S	S	S	S	M	M	S	S	S	L
PEO3	L	M	M	L	L	S	S	S	S	M	S	M

*S – Strong**M-Medium**L-Low***Programme Specific Outcomes (PSO):**

After the successful completion of the B.E. Mechatronics Engineering degree programme, the students will be able to:

PSO1:

Design, develop and retrofit conventional mechanical system into low-cost automated system using sensors and controllers

PSO2:

Design, develop and analyse mechatronics system using hardware and software tools.

SCHEDULING OF COURSES

Semester	Theory						Theory cum Practical	Practical		Special Courses	Credits
	1	2	3	4	5	6	7	8	9	10	
I	14MA110 Engineering Mathematics-I (3)	14PH120 Physics (3)	14CH130 Chemistry (3)	14EG141 English (3)	14ES150 Basics of Civil and Mechanical Engineering (2)	14ES160 Basics of Electrical and Electronics Engineering (2)	14ME170 Engineering Graphics (3)	14PH180 Physics Lab (1)	14CH190 Chemistry Lab (1)	-	21
II	14MT210 Engineering Mathematics (3)	14MT220 Free Body Mechanics (3)	14MT230 Electrical Machines (3)	14MT240 Materials For Mechanical and Electronic Systems (3)	14MT250 Environmental Science and Engineering (3)	-	14MT270 Analog and Digital Devices (3)	14MT280 Electrical Machines Lab (1)	14MT290 Workshop (1)	-	20
III	14MT310 Fourier Analysis and Partial differential equations (3)	14MT320 Kinematics and Dynamics of Machinery (3)	14MT330 Sensors and PLC (3)	14MT340 Thermal Engg. and Fluid Mechanics (3)	14MT350 Manufacturing Processes (3)	-	14MT370 Problem Solving using Computer (3)	14MT380 Thermal Engineering Lab (1)	14MT390 Manufacturing Processes Lab (1)	-	20
IV	14MT410 Linear Algebra and Numerical Methods (3)	14MT420 Engineering Design (3)	14MT430 Analog & Digital Circuits Design (3)	14MT440 Metrology and Measurements (3)	14MT450 Fluid Power Automation (3)	-	14MT470 Professional Communication (2)	14MT480 Automation Lab (1)	14MT490 Metrology & Measurement Lab (1)	14MT4C1 Capstone Course-I (2)	21
V	14MT510 Optimization Techniques (3)	14MT520 Control System (3)	14MT530 Power Electronics and Drives (3)	14MT540 CNC Technology (3)	14MTPX0 Prog. Elec.I (3)	14MTGX0 Gen.Elec. (3)	14MT570 Microcontrollers (3)	14MT580 CAD/CAM Lab (1)	14MT590 Analog and Digital Circuit Design Lab (1)	-	23
VI	14MT610 Accounting and Finance (3)	14MT620 Industrial Robotics (3)	14MT630 Mechatronic System Design (3)	14MT640 Digital Signal Processing (3)	14MTPX0 Prog. Elec.II (3)	-	-	14MT680 Dynamics & Control Lab (1)	14MT690 Robotics Lab (1)	-	18
VII	14MT710 Project Management (3)	14MT720 Unmanned Aerial Vehicles (3)	14MTPX0 Prog. Elec.III (3)	14MTPX0 Prog. Elec.IV (3)	14MTGX0 Gen.Elec. (3)	-	14MT770 System Integration (4)	-	-	14MT7C0 Capstone Course-II (2)	21
VIII	14MTPX0 Prog. Elec.V (3)	14MTPX0 Prog. Elec.VI (3)	14MTPX0 Prog. Elec.VII (3)	-	-	-	-	14MT880 Project (12)		-	21

Total Credits for Curricular Activities: 164

Credit Distribution

S.No.	Category	Credits	Institute Requirement	Department Core
1.	Humanities and Social Sciences	15	15	0
2.	Basic Sciences	26	5-11	15
3.	Engineering sciences	21	11-14	7
4.	Programme Core	63	0	63
5.	Programme Electives	21	0	21
6.	Project	12	0	12
7.	General Electives	6	6	0
Total Credits		164	37-46	118-127

- General electives are courses offered by different departments that do not have any prerequisites and could be of interest to students of any branch
- All students have to undertake co-curricular and extra-curricular activities that include activities related to NCC, NSS, Sports, Professional Societies, participation in identified activities which promote the growth of Departments and the College

BASIC SCIENCE COURSES **20-26**

Engineering Mathematics-1 (Common)	3
Engineering Mathematics-2 (Programme Specific)	3
Engineering Mathematics-3 (Programme Specific)	3
Engineering Mathematics-4 (Programme Specific)	3
Engineering Mathematics-5 (Programme Specific)	3
(As per the Individual programme Requirement)	
Physics	3
Physics Laboratory	1
Chemistry	3
Chemistry Laboratory	1
Department selected course (Programme Specific)	3
(As per the individual programme Requirement)	

HUMANITIES AND SOCIAL SCIENCES COURSES **15**

English	3
Professional Communication (Theory cum practical)	3
Project Management	3
Accounting and Finance	3
Environment Science	3

ENGINEERING SCIENCE COURSES **18-21**

Basics of Civil and Mechanical Engineering	2
Basics of Electrical & Electronics Engineering	2
Engineering Graphics	3
Engineering by Design	3
Problem Solving using Computers	3
Workshop	1
Capstone Course –I	2
Capstone Course-II	2
Data Structures (CSE, IT, ECE)	3

PROGRAMME CORE **63-72**
(Foundation, System, Application)

PROGRAMME ELECTIVES **21**

GENERAL ELECTIVES **06**

PROJECT **12**

Total **164**

Degree: B.E.

Programme: Mechatronics

A. Foundation Courses:

Credits to be earned: (48-63)

a. Humanities and Social Science (12-15)

Sl. No	Course Code	Name of the Course	Number of Hours / Week			Credit	Prerequisite
			L	T	P		
THEORY							
1.	14EG141	English	3	0	0	3	Nil
2.	14MT250	Environmental Science and Engineering	3	0	0	3	Nil
3.	14MT610	Accounting and Finance	3	0	0	3	Nil
4.	14MT710	Project Management	3	0	0	3	Nil
THEORY CUM PRACTICAL							
5.	14MT470	Professional Communication	1	0	2	2	Nil
Total						14	

b. Basic Science (15-21)

Sl. No	Course Code	Name of the Course	Number of Hours / Week			Credit	Prerequisite
			L	T	P		
THEORY							
6.	14MA110	Engineering Mathematics-I	2	2	0	3	Nil
7.	14PH120	Physics	3	0	0	3	Nil
8.	14CH130	Chemistry	3	0	0	3	Nil
9.	14MT210	Engineering Mathematics	2	2	0	3	Nil
10.	14MT310	Fourier Analysis and Partial differential Equation	2	2	0	3	Nil
11.	14MT410	Linear Algebra and Numerical Methods	2	2	0	3	Nil
PRACTICAL							
12.	14PH180	Physics Lab	0	0	2	1	Nil
13.	14CH190	Chemistry Lab	0	0	2	1	Nil
Total						20	

c. Engineering Science (15-21)

Sl. No.	Course Code	Name of the Course	Number of Hours / Week			Credit	Prerequisite
			L	T	P		
THEORY							
14.	14ES150	Basics of Civil and Mechanical Engineering	2	0	0	2	Nil
15.	14ES160	Basics of Electrical and Electronics Engineering	2	0	0	2	Nil
16.	14MT240	Materials for Mechanical and Electronics System	3	0	0	3	Nil
17.	14MT420	Engineering Design	1	0	2	2	Nil
18.	14MT510	Optimisation Techniques.	2	2	0	3	Nil
THEORY CUM PRACTICAL							
19.	14ME170	Engineering Graphics	2	0	2	3	Nil
20.	14MT370	Problem solving using Computer	2	0	2	3	Nil

d. Elective Foundation Courses (HSS, BS and ES) Credits to be earned: 06**B. Core Courses:****Credits to be earned: (63-72)**

Sl. No.	Course Code	Name of the Course	Number of Hours / Week			Credit	Prerequisite
			L	T	P		
THEORY							
1	14MT220	Free Body Mechanics	2	2	0	3	Nil
2	14MT230	Electrical Machines	3	0	0	3	Nil
3	14MT320	Kinematics and Dynamics of Machinery	2	2	0	3	Nil
4	14MT330	Sensors and PLC	2	2	0	3	Nil
5	14MT340	Thermal Engineering and Fluid Mechanics	2	2	0	3	Nil
6	14MT350	Manufacturing Processes	3	0	0	3	Nil
7	14MT430	Analog and Digital Circuits Design	3	0	0	3	Nil
8	14MT440	Metrology and Measurements	3	0	0	3	14MT330
9	14MT450	Fluid Power Automation	3	0	0	3	Nil
10	14MT520	Control Systems	3	0	0	3	Nil
11	14MT530	Power Electronics and Drives	3	0	0	3	Nil
12	14MT540	CNC Technology	3	0	0	3	14MT330 14MT350
13	14MT620	Industrial Robotics	3	0	0	3	Nil
14	14MT630	Mechatronic System Design	3	0	0	3	14MT330 14MT420

							14MT430 14MT520
15	14MT640	Digital Signal Processing	3	0	0	3	14MT310
16	14MT720	Unmanned Aerial Vehicles	3	0	0	3	-
						51	
THEORY CUM PRACTICAL							
17	14MT270	Analog and Digital Devices	2	0	2	3	
18	14MT570	Microcontrollers	2	0	2	3	14MT430
19	14MT770	System Integration	2	0	2	4	-
						10	
PRACTICAL							
20	14MT280	Electrical Machines Lab	0	0	2	1	Nil
21	14MT290	Workshop	0	0	2	1	Nil.
22	14MT380	Thermal Engineering Lab	0	0	2	1	Nil
23	14MT390	Manufacturing Processes Lab	0	0	2	1	Nil
24	14MT480	Automation Lab	0	0	2	1	Nil
25	14MT490	Metrology and Measurement Lab	0	0	2	1	Nil
26	14MT4C1	Capstone Course –I	0	0	2	2	Nil
27	14MT580	CAD/CAM Lab	0	0	2	1	Nil
28	14MT590	Analog and Digital Circuit Design Lab	0	0	2	1	14MT430
29	14MT680	Dynamics and Control Lab	0	0	2	1	14MT320 14MT520
30	14MT690	Robotics Lab	0	0	2	1	Nil
31	14MT7C0	Capstone Course –II	0	0	2	2	Nil
						14	

C. Elective Courses:**Credits to be earned: (27 - 39)****a. Programme Specific Elective (12- 15)****b. Programme Specific Elective for Expanded Scope (09-12)**

S.No	Course Code	Name of the Course	Number of Hours / Week			Credit	Prerequisite
			L	T	P		
THEORY							
1.	14MTPA0	Machine Vision System	3	0	0	3	Nil
2.	14MTPB0	Micro Electro Mechanical Systems	3	0	0	3	Nil
3.	14MTPC0	Additive Manufacturing	3	0	0	3	Nil
4.	14MTPD0	Integrated Product Development	3	0	0	3	14MT420
5.	14MTPD0	VERILOG HDL	3	0	0	3	14MT430
6.	14MTPG0	Smart materials for Mechatronics	3	0	0	3	Nil
7.	14MTPH0	Embedded system	3	0	0	3	14MT570
8.	14MTPJ0	Programming for Robotics	3	0	0	3	14MT320

		system					14MT370 14MT620
9.	14MTPN0	Automotive Mechatronics	3	0	0	3	14MT440 14MT450
10.	14MTPP0	Artificial Intelligence	3	0	0	3	Nil.
11.	14MTPQ0	Modern Control Systems	3	0	0	3	14MT520
12.	14MTPU0	Mobile Robotics	3	0	0	3	Nil
13.	14MTPW0	Virtual Instrumentation	3	0	0	3	Nil
14.	14MTRA0	Selection & Integration of Sensors	3	0	0	3	14MT430, 14MT440
Programme Specific Elective for Expanded Scope (09-12)							
15.	14MTPF0	Total Quality management	3	0	0	3	Nil.
16.	14MTPK0	Industry Internet of Things	3	0	0	3	14MT330 14MT570
17.	14MTPM0	Industrial Communication Networks	3	0	0	3	Nil.
18.	14MTPR0	Mechanical and Thermal Packaging of Electronics.	3	0	0	3	Nil
19.	14MTPT0	Data Analytics	3	0	0	3	Nil
20.	14MTPY0	Design of Machine Elements	3	0	0	3	14MT210 14MT320
21.	14MT1A0	Elevator System Design	1	0	0	1	Nil
22.	14MT1B0	Motion Logic Drives & Controls	1	0	0	1	Nil
23.	14MT1C0	Mobile Hydraulics	1	0	0	1	Nil
24.	14MT1D0	Integrated Building Management System	1	0	0	1	Nil
25.	14MT1E0	Electromagnetic Interference & Compatibility	1	0	0	1	Nil
26.	14MT2A0	Reliability for Mechatronics Systems	2	0	0	2	Nil
27.	14MT1F0	Biomechatronics	1	0	0	1	Nil

C. Interdisciplinary Elective**Credits to be earned: 06 -12****D. Project**

S.No	Course Code	Name of the Course	Number of Hours / Week			Credit	Prerequisite
			L	T	P		
PRACTICAL							
1	14MT880	Project	0	0	0	12	-

THIAGARAJAR COLLEGE OF ENGINEERING: MADURAI – 625 015
B.E. / B.Tech. Degree Programmes

COURSES OF STUDY
 (For the candidates admitted from 2014-15 onwards)

FIRST SEMESTER

Course Code	Name of the Course	Category	No. of Hours / Week			credits
			L	T	P	
THEORY						
14MA110	Engineering Mathematics I	BS	2	2	-	3
14PH120	Physics	BS	3	-	-	3
14CH130	Chemistry	BS	3	-	-	3
14EG141	English	HSS	3	-	-	3
14ES150	Basics of Civil and Mechanical Engineering	ES	2	-	-	2
14ES160	Basics of Electrical and Electronics Engineering	ES	2	-	-	2
THEORY CUM PRACTICAL						
14ME170	Engineering Graphics	ES	2	-	2	3
PRACTICAL						
14PH180	Physics Laboratory	BS	-	-	2	1
14CH190	Chemistry Laboratory	BS	-	-	2	1
Total			17	2	6	21

BS : Basic Science
 HSS : Humanities and Social Science
 ES : Engineering Science

L : Lecture
 T : Tutorial
 P : Practical

Note:

1 Hour Lecture is equivalent to 1 credit
 2 Hours Tutorial is equivalent to 1 credit
 2 Hours Practical is equivalent to 1 credit

THIAGARAJAR COLLEGE OF ENGINEERING: MADURAI – 625 015**B.E. / B.Tech. Degree Programme****SCHEME OF EXAMINATIONS**

(For the candidates admitted from 2014-15 onwards)

FIRST SEMESTER

S.No.	Course Code	Name of the Course	Duration of Terminal Exam. in Hrs.	Marks			Minimum Marks for Pass	
				Continuous Assessment *	Terminal Exam **	Max. Marks	Terminal Exam	Total
THEORY								
1	14MA110	Engineering Mathematics I	3	50	50	100	25	50
2	14PH120	Physics	3	50	50	100	25	50
3	14CH130	Chemistry	3	50	50	100	25	50
4	14EG141	English	3	50	50	100	25	50
5	14ES150	Basics of Civil and Mechanical Engineering	3	50	50	100	25	50
6	14ES160	Basics of Electrical and Electronics Engineering	3	50	50	100	25	50
THEORY CUM PRACTICAL								
7	14ME170	Engineering Graphics	3	50	50	100	25	50
PRACTICAL								
8	14PH180	Physics Laboratory	3	50	50	100	25	50
9	14CH190	Chemistry Laboratory	3	50	50	100	25	50

* CA evaluation pattern will differ from course to course and for different tests. This will have to be declared in advance to students. The department will put a process in place to ensure that the actual test paper follow the declared pattern.

** Terminal Examination will be conducted for maximum marks of 100 and subsequently be reduced to 50 marks for the award of terminal examination marks

THIAGARAJAR COLLEGE OF ENGINEERING: MADURAI – 625 015.**B.E. DEGREE (Mechatronics) PROGRAMME****SUBJECTS OF STUDY**

(For the candidates admitted from 2014-2015 onwards)

SECOND SEMESTER

Subject Code	Name of the subject	Category	No. of Hours / Week			Credits
			L	T	P	
THEORY						
14MT210	Engineering Mathematics-II	BS	2	2	-	3
14MT220	Free Body Mechanics	PC	2	2	-	3
14MT230	Electrical Machines	PC	3	0	-	3
14MT240	Materials For Mechanical and Electronic Systems	PC	3	0	-	3
14MT250	Environmental Science and Engineering	HSS	3	0	-	3
14MT270	Analog and Digital Devices(Theory Cum Practical)	PC	2	0	2	3
PRACTICAL						
14MT280	Electrical Machines Lab	PC	-	-	2	1
14MT290	Workshop	PC	-	-	2	1
Total						20

**** BS- Basic Sciences; HSS-Humanities and Social Sciences; ES-Engineering Sciences; PC- Programme Core; PE-Programme Elective; GE-General Elective; OC-One Credit Course; TC- Two Credit Course; SS-Slef-Study Course (in the list of Programme Electives)**

Note:

1 Hour Lecture/Tutorial is equivalent to 1 credit

2/3 Hours Practical is equivalent to 1 credit

THIAGARAJAR COLLEGE OF ENGINEERING: MADURAI – 625 015.**B.E. DEGREE (Mechatronics) PROGRAMME****SCHEME OF EXAMINATIONS**

(For the candidates admitted from 2014-2015 onwards)

SECOND SEMESTER

S.No	Sub. Code	Name of the subject	Duration of Terminal Exam. in Hrs.	Marks			Minimum Marks for Pass		
				Continuou s Assessmen t *	Termin al Exam **	Max. Marks	Terminal Exam	Total	
THEORY									
1	14MT210	Engineering Mathematics-II	3	50	50	100	25	50	
2	14MT220	Free Body Mechanics	3	50	50	100	25	50	
3	14MT230	Electrical Machines	3	50	50	100	25	50	
4	14MT240	Materials For Mechanical and Electronic Systems	3	50	50	100	25	50	
5	14MT250	Environmental Science and Engineering	3	50	50	100	25	50	
6	14MT270	Analog and Digital Devices(Theory Cum Practical)	3	T: 20	P: 30	T:50	100	25	50
PRACTICAL									
7	14MT280	Electrical Machines Lab	3	50	50	100	25	50	
8	14MT290	Workshop	3	100	-	100	-	50	

* Continuous Assessment evaluation pattern will differ from subject to subject and for different tests. This will have to be declared in advance to students. The department will put a process in place to ensure that the actual test paper follow the declared pattern.

** Terminal Examination will be conducted for maximum marks of 100 and subsequently be reduced to 50 marks for the award of terminal examination marks.

THIAGARAJAR COLLEGE OF ENGINEERING: MADURAI – 625 015.**B.E. DEGREE (Mechatronics) PROGRAMME****COURSES OF STUDY**

(For the candidates admitted from 2014-2015 onwards)

THIRD SEMESTER

Course Code	Name of the Course	Category **	No. of Hours / Week			Credits
			L	T	P	
THEORY						
14MT310	Fourier Analysis and Partial Differential Equations	BS	2	2	-	3
14MT320	Kinematics and Dynamics of Machinery	PC	2	2	-	3
14MT330	Sensors and PLC	PC	3	0	-	3
14MT340	Thermal Engg. and Fluid Mechanics	PC	2	2	-	3
14MT350	Manufacturing Processes	PC	3	0	-	3
THEORY CUM PRACTICAL						
14MT370	Problem solving using Computer	PC	2	0	2	3
PRACTICAL						
14MT380	Thermal Engineering Lab	PC	-	-	2	1
14MT390	Manufacturing Processes Lab	PC	-	-	2	1
Total			14	6	6	20

** BS- Basic Sciences; HSS-Humanities and Social Sciences; ES-Engineering Sciences; PC- Programme Core; PE-Programme Elective; GE-General Elective; OC-One Credit Course; TC- Two Credit Course; SS-Self-Study Course (in the list of Programme Electives)

Note:

1 hour Lecture/2 hours Tutorial is equivalent to 1 credit

2 hours Practical is equivalent to 1 credit

THIAGARAJAR COLLEGE OF ENGINEERING: MADURAI – 625 015.**B.E. DEGREE (Mechatronics) PROGRAMME****SCHEME OF EXAMINATIONS**

(For the candidates admitted from 2014-2015 onwards)

THIRD SEMESTER

S.No.	Course Code	Name of the Course	Duration of Terminal Exam. in Hrs.	Marks			Minimum Marks for Pass	
				Continuou s Assessment	Terminal Exam *	Max. Marks	Terminal Exam	Total
THEORY								
1	14MT310	Fourier Analysis and Partial Differential Equations	3	50	50	100	25	50
2	14MT320	Kinematics and Dynamics of Machinery	3	50	50	100	25	50
3	14MT330	Sensors and PLC	3	50	50	100	25	50
4	14MT340	Thermal Engg. and Fluid Mechanics	3	50	50	100	25	50
5	14MT350	Manufacturing Processes	3	50	50	100	25	50
THEORY CUM PRACTICAL								
6	14MT370	Problem solving using Computer	3	50**	50	100	25	50
PRACTICAL								
7	14MT380	Thermal Engineering Lab	3	50	50	100	25	50
8	14MT390	Manufacturing Processes Lab	3	50	50	100	25	50

* Continuous Assessment evaluation pattern will differ from subject to subject and for different tests. This will have to be declared in advance to students. The department will put a process in place to ensure that the actual test paper follow the declared pattern.

** Terminal Examination will be conducted for maximum marks of 100 and subsequently be reduced to 50 marks for the award of terminal examination marks.

THIAGARAJAR COLLEGE OF ENGINEERING: MADURAI – 625 015.**B.E. DEGREE (Mechatronics) PROGRAMME****COURSES OF STUDY**

(For the candidates admitted from 2014-2015 onwards)

FOURTH SEMESTER

Course Code	Name of the Course	Category **	No. of Hours / Week			Credits
			L	T	P	
THEORY						
14MT410	Linear algebra and Numerical Methods	BS	2	2	-	3
14MT420	Engineering by Design	PC	1	0	4	3
14MT430	Analog and Digital circuits Design	PC	3	0	-	3
14MT440	Metrology and Measurements	PC	3	0	-	3
14MT450	Fluid Power Automation	PC	3	0	-	3
THEORY CUM PRACTICAL						
14MT470	Professional Communication	HSS	1	0	2	2
PRACTICAL						
14MT480	Automation Lab	PC	-	-	2	1
14MT490	Metrology and Measurements Lab	PC	-	-	2	1
SPECIAL COURSES						
14MT4C1	Capstone Course – I	PC	2	-	-	2
Total			15	2	10	21

** BS- Basic Sciences; HSS-Humanities and Social Sciences; ES-Engineering Sciences; PC- Programme Core; PE-Programme Elective; GE-General Elective; OC-One Credit Course; TC- Two Credit Course; SS-Self-Study Course (in the list of Programme Electives)

Note:

1 hour Lecture/2 hours Tutorial is equivalent to 1 credit

2 hours Practical is equivalent to 1 credit

THIAGARAJAR COLLEGE OF ENGINEERING: MADURAI – 625 015.**B.E. DEGREE (Mechatronics) PROGRAMME****SCHEME OF EXAMINATIONS**

(For the candidates admitted from 2014-2015 onwards)

FOURTH SEMESTER

S.No.	Course Code	Name of the Course	Duration of Terminal Exam. in Hrs.	Marks			Minimum Marks for Pass	
				Continuou s Assessment	Terminal Exam *	Max. Marks	Terminal Exam	Total
THEORY								
1	14MT410	Linear Algebra and Numerical Methods	3	50	50	100	25	50
2	14MT420	Engineering Design	3	50	50	100	25	50
3	14MT430	Analog and Digital Circuits Design	3	50	50	100	25	50
4	14MT440	Metrology and Measurements	3	50	50	100	25	50
5	14MT450	Fluid Power Automation	3	50	50	100	25	50
THEORY CUM PRACTICAL								
6	14MT470	Professional Communication	3	50**	50	100	25	50
PRACTICAL								
7	14MT480	Automation Lab	3	50	50	100	25	50
8	14MT490	Metrology and Measurements lab	3	50	50	100	25	50
SPECIAL COURSES								
9	14MT4C1	Capstone Course – I	2					

* Terminal Examination will be conducted for maximum marks of 100 and subsequently be reduced to 50 marks for the award of terminal examination marks.

** Theory -20 marks, Practical -30 marks.

THIAGARAJAR COLLEGE OF ENGINEERING: MADURAI – 625 015.**B.E. DEGREE (Mechatronics) PROGRAMME****COURSES OF STUDY**

(For the candidates admitted from 2014-2015 onwards)

FIFTH SEMESTER

Course Code	Name of the Course	Category **	No. of Hours / Week			Credits
			L	T	P	
THEORY						
14MT510	Optimization Techniques	BS	2	2	0	3
14MT520	Control System	PC	3	0	0	3
14MT530	Power Electronics and drives	PC	3	0	0	3
14MT540	CNC Technology	PC	3	0	0	3
THEORY CUM PRACTICAL						
14MT570	Microcontrollers	HSS	2	0	2	3
PRACTICAL						
14MT580	CAD/CAM Lab	PC	0	0	2	1
14MT590	Analog and Digital Circuit Design Lab	PC	0	0	2	1
ELECTIVES						
14MTPX0	Program Elective I	PE	3	0	0	3
Total			16	2	6	20

** BS- Basic Sciences; HSS-Humanities and Social Sciences; ES-Engineering Sciences; PC- Programme Core; PE-Programme Elective; GE-General Elective; OC-One Credit Course; TC- Two Credit Course; SS-Self-Study Course (in the list of Programme Electives)

Note:

1 hour Lecture/2 hours Tutorial is equivalent to 1 credit

2 hours Practical is equivalent to 1 credit

THIAGARAJAR COLLEGE OF ENGINEERING: MADURAI – 625 015.**B.E. DEGREE (Mechatronics) PROGRAMME****SCHEME OF EXAMINATIONS**

(For the candidates admitted from 2014-2015 onwards)

FIFTH SEMESTER

S.No.	Course Code	Name of the Course	Duration of Terminal Exam. in Hrs.	Marks			Minimum Marks for Pass	
				Continuou s Assessment	Terminal Exam *	Max. Marks	Terminal Exam	Total
THEORY								
1	14MT510	Optimization Techniques	3	50	50	100	25	50
2	14MT520	Control System	3	50	50	100	25	50
3	14MT530	Power Electronics and drives	3	50	50	100	25	50
4	14MT540	CNC Technology	3	50	50	100	25	50
THEORY CUM PRACTICAL								
5	14MT570	Microcontroller s	3	50**	50	100	25	50
PRACTICAL								
6	14MT580	CAD/CAM Lab	3	50	50	100	25	50
7	14MT590	Analog and Digital Circuit Design Lab	3	50	50	100	25	50
ELECTIVES								
8	14MTPX0	Program Elective I	3	50	50	100	25	50

* Terminal Examination will be conducted for maximum marks of 100 and subsequently be reduced to 50 marks for the award of terminal examination marks.

** Theory -20 marks, Practical -30 marks.

THIAGARAJAR COLLEGE OF ENGINEERING: MADURAI – 625 015.**B.E. DEGREE (Mechatronics) PROGRAMME****COURSES OF STUDY**

(For the candidates admitted from 2014-2015 onwards)

SIXTH SEMESTER

Course Code	Name of the Course	Category **	No. of Hours / Week			credits
			L	T	P	
THEORY						
14MT610	Accounting and finance	BS	3	0	0	3
14MT620	Industrial Robotics	PC	3	0	0	3
14MT630	Mechatronics system Design	PC	3	0	0	3
14MT640	Digital Signal Processing	PC	3	0	0	3
14MTPX0	Program Elective II	PE	3	0	0	3
PRACTICAL						
14MT680	Dynamics and Control Lab	PC	0	0	2	1
14MT690	Robotics Lab	PC	0	0	2	1
Total			18	04		20

** BS- Basic Sciences; HSS-Humanities and Social Sciences; ES-Engineering Sciences; PC- Programme Core; PE-Programme Elective; GE-General Elective; OC-One Credit Course; TC- Two Credit Course; SS-Self-Study Course (in the list of Programme Electives)

Note:

1 hour Lecture/2 hours Tutorial is equivalent to 1 credit

2 hours Practical is equivalent to 1 credit

THIAGARAJAR COLLEGE OF ENGINEERING: MADURAI – 625 015.
B.E. DEGREE (Mechatronics) PROGRAMME
SCHEME OF EXAMINATIONS
(For the candidates admitted from 2014-2015 onwards)

SIXTH SEMESTER

S. No.	Course Code	Name of the Course	Duration of Terminal Exam. in Hrs.	Marks			Minimum Marks for Pass	
				Continuou s Assessment	Termi nal Exam *	Max. Mark s	Terminal Exam	Total
THEORY								
1	14MT610	Accounting and finance	3	50	50	100	25	50
2	14MT620	Industrial Robotics	3	50	50	100	25	50
3	14MT630	Mechatronics system Design	3	50	50	100	25	50
4	14MT640	Digital Signal Processing	3	50	50	100	25	50
5	14MTPX0	Program Elective II	3	50	50	100	25	50
PRACTICAL								
6	14MT680	Dynamics and Control Lab	3	50	50	100	25	50
7	14MT690	Robotics Lab	3	50	50	100	25	50

* Terminal Examination will be conducted for maximum marks of 100 and subsequently be reduced to 50 marks for the award of terminal examination marks.

** Theory -20 marks Practical -30 marks.

THIAGARAJAR COLLEGE OF ENGINEERING: MADURAI – 625 015.**B.E. DEGREE (Mechatronics) PROGRAMME****COURSES OF STUDY**

(For the candidates admitted from 2014-2015 onwards)

SEVENTH SEMESTER

Course Code	Name of the Course	Category **	No. of Hours / Week			Credits
			L	T	P	
THEORY						
14MT710	Project Management	HSS	3	0	0	3
14MT720	Unmanned Aerial Vehicles	PC	3	0	0	3
14MTPX0	Program Elective III	PE	3	0	0	3
14MTPX0	Program Elective IV	PE	3	0	0	3
THEORYCUM PRACTICAL						
14MT770	System Integration(T&P)	PC	3	0	2	4
SPECIAL COURSES						
14MT7C0	Capstone Course – II	PC	2	0	0	2
Total			20	0	2	21

** BS- Basic Sciences; HSS-Humanities and Social Sciences; ES-Engineering Sciences; PC- Programme Core; PE-Programme Elective; GE-General Elective; OC-One Credit Course; TC- Two Credit Course; SS-Self-Study Course (in the list of Programme Electives)

Note:

1 hour Lecture/2 hours Tutorial is equivalent to 1 credit

2 hours Practical is equivalent to 1 credit

THIAGARAJAR COLLEGE OF ENGINEERING: MADURAI – 625 015.

**B.E. DEGREE (Mechatronics) PROGRAMME
SCHEME OF EXAMINATIONS**
(For the candidates admitted from 2014-2015 onwards)

SEVENTH SEMESTER

S. No.	Course Code	Name of the Course	Duration of Terminal Exam. in Hrs.	Marks			Minimum Marks for Pass	
				Continuou s Assessment	Terminal Exam *	Max. Marks	Terminal Exam	Total
THEORY								
1	14MT710	Project Management	3	50	50	100	25	50
2	14MT720	Unmanned Aerial Vehicles	3	50	50	100	25	50
3	14MTPX0	Program Elective III	3	50	50	100	25	50
4	14MTPX0	Program Elective IV	3	50	50	100	25	50
THEORY CUM PRACTICAL								
5	14MT770	System Integration(T&P)	3	50**	50	100	25	50
SPECIAL COURSES								
6	14MT7C0	Capstone Course II	-	100	-	100	-	50

* Terminal Examination will be conducted for maximum marks of 100 and subsequently be reduced to 50 marks for the award of terminal examination marks.

** Theory -20 marks Practical -30 marks.

THIAGARAJAR COLLEGE OF ENGINEERING: MADURAI – 625 015.**B.E. DEGREE (Mechatronics) PROGRAMME****COURSES OF STUDY**

(For the candidates admitted from 2014-2015 onwards)

EIGHTH SEMESTER

Course Code	Name of the Course	Category **	No. of Hours / Week			credits
			L	T	P	
THEORY						
14MTPX0	Program Elective V	PE	3	0	0	3
14MTPX0	Program Elective VI	PE	3	0	0	3
14MTPX0	Program Elective VII	PE	3	0	0	3
PRACTICAL						
14MT880	Project	PC	0	0	24	12
Total			9	0	24	21

** BS- Basic Sciences; HSS-Humanities and Social Sciences; ES-Engineering Sciences; PC- Programme Core; PE-Programme Elective; GE-General Elective; OC-One Credit Course; TC- Two Credit Course; SS-Self-Study Course (in the list of Programme Electives)

Note:

1 hour Lecture/2 hours Tutorial is equivalent to 1 credit

2 hours Practical is equivalent to 1 credit

THIAGARAJAR COLLEGE OF ENGINEERING: MADURAI – 625 015.

**B.E. DEGREE (Mechatronics) PROGRAMME
SCHEME OF EXAMINATIONS**
(For the candidates admitted from 2014-2015 onwards)

EIGHTH SEMESTER

Sl. No.	Course Code	Name of the Course	Duration of Terminal Exam. in Hrs.	Marks			Minimum Marks for Pass	
				Continuous Assessment	Terminal Exam *	Max. Marks	Terminal Exam	Total
THEORY								
1	14MTPX0	Program Elective V	3	50	50	100	25	50
2	14MTPX0	Program Elective VI	3	50	50	100	25	50
3	14MTPX0	Program Elective VII	3	50	50	100	25	50
PRACTICAL								
4	14MT880	Project	--	150	150	300	75	150

* Terminal Examination will be conducted for maximum marks of 100 and subsequently be reduced to 50 marks for the award of terminal examination marks.

** Theory -20 marks Practical -30 marks.

PROGRAM ELECTIVES						
14MTPA0	Machine Vision System	PE	3	-	-	3
14MTPB0	Micro Electro Mechanical Systems	PE	3	-	-	3
14MTPC0	Additive Manufacturing	PE	3	-	-	3
14MTPD0	Integrated Product Development	PE	3	-	-	3
14MTPE0	VERILOG HDL	PE	3	-	-	3
14MTPF0	Total Quality management	PE	3	-	-	3
14MTPG0	Smart materials for Mechatronics	PE	3	-	-	3
14MTPH0	Embedded system	PE	3	-	-	3
14MTPJ0	Programming for Robotics system	PE	3	-	-	3
14MTPK0	Industry Internet of Things	PE	3	-	-	3
14MTPM0	Industrial Communication Networks	PE	3	-	-	3
14MTPN0	Automotive Mechatronics	PE	3	-	-	3
14MTPP0	Artificial Intelligence	PE	3	-	-	3
14MTPQ0	Modern Control Systems	PE	3	-	-	3
14MTPR0	Mechanical and Thermal Packaging of Electronics.	PE	3	-	-	3
14MTPT0	Data Analytics	PE	3	-	-	3
14MTPU0	Mobile Robotics	PE	3	-	-	3
14MTPW0	Virtual Instrumentation	PE	3	-	-	3
14MTPY0	Design of Machine Elements.	PE	3	-	-	3
14MTRA0	Selection and Integration of sensors	PE	3	-	-	3
GENERAL ELECTIVES						
14MTGA0	Industrial Automation	PE	3	-	-	3
14MTGB0	Mechatronics	PE	3	-	-	3
14MTGC0	Total Quality Management	PE	3	-	-	3
14MTGD0	Sensors	PE	3	-	-	3

CURRICULUM AND DETAILED SYLLABI

FOR

B.E. / B.Tech. DEGREE PROGRAMME

FIRST SEMESTER

FOR THE STUDENTS ADMITTED IN THE

ACADEMIC YEAR 2014-15 ONWARDS

THIAGARAJAR COLLEGE OF ENGINEERING

(A Government Aided ISO 9001:2008 certified Autonomous Institution affiliated to Anna University)

MADURAI – 625 015, TAMILNADU

Phone: 0452 – 2482240, 41

Fax: 0452 2483427

Web: www.tce.edu

		Category	L	T	P	Credit
14MA110	ENGINEERING MATHEMATICS - I	BS	2	2	0	3

Preamble

The driving force in engineering mathematics is the rapid growth of technology and the sciences. Matrices have been found to be of great utility in many branches of engineering applications such as theory of electric circuits, aerodynamics, mechanics and so on. Many physical laws and relations can be expressed mathematically in the form of differential equations. Based on this we provide a course in matrices, calculus and differential equations.

Prerequisite

NIL

Course Outcomes

On the successful completion of the course, students will be able to	
CO1: Find the inverse and the positive powers of a square matrix	Understand
CO2: Apply the concept of orthogonal reduction to diagonalise the given matrix	Apply
CO3: Find the radius of curvature, circle of curvature and centre of curvature for a given curve.	Understand
CO4: Determine the evolute and envelope for a given family of curves	Apply
CO5: Classify the maxima and minima for a given function with several variables, through by finding stationary points	Analyse
CO6: Apply Lagrangian multiplier method for finding maxima and minima of an unconstrained problem	Apply
CO7: Predict the suitable method to solve second and higher order differential equations	Apply

Assessment Pattern

Bloom's Category	Continuous Assessment Tests			Terminal Examination
	1	2	3	
Remember	10	10	10	20
Understand	30	30	30	20
Apply	40	40	40	50
Analyse	20	20	20	10
Evaluate	0	0	0	0
Create	0	0	0	0

Course Level Assessment Questions

Course Outcome 1 (CO1):

- Suppose an $n \times n$ matrices A and B have the same eigen values $\lambda_1, \lambda_2, \dots, \lambda_n$ with the same Independent eigen vectors X_1, X_2, \dots, X_n . Show that A = B.

2. Find the 2x2 matrix having eigen values $\lambda_1=2$ and $\lambda_2=5$ with corresponding eigen vectors $X_1 = \begin{pmatrix} 1 \\ 0 \end{pmatrix}$, $X_2 = \begin{pmatrix} 1 \\ 1 \end{pmatrix}$.

3. Find A^{-1} and A^4 for a given square matrix $A = \begin{pmatrix} 7 & 2 & -2 \\ -6 & -1 & 2 \\ 6 & 2 & -1 \end{pmatrix}$, using Cayley Hamilton theorem.

4. Compute the eigenvalues and eigenvectors of $A = \begin{pmatrix} 7 & 2 & - \\ 1 & 1 & -2 \\ -1 & -2 & 1 \end{pmatrix}$

Course Outcome 2 (CO2):

1. Transfer the given quadratic form $6x_1^2 + 3x_2^2 + 14x_3^2 + 4x_1x_2 + 4x_2x_3 + 18x_3x_1$ to canonical by an orthogonal transformation.

2. Diagonalise the matrix $A = \begin{pmatrix} 8 & -6 & 2 \\ -6 & 7 & -4 \\ 2 & -4 & 3 \end{pmatrix}$

3. Discuss when a quadratic form is singular. What is the rank then?

Course Outcome 3 (CO3)

1. Predict the radius of curvature of the curve $x^3 + xy^2 - 6y^2 = 0$ at (3,3).
 2. Identify the centre of curvature of the curve $y = x^3 - 6x^2 + 3x + 1$ at (1,-1).
 3. Find the equation of the circle of curvature of the curve $y^3 + x^3 = 3axy$ at the point $\left(\frac{3a}{2}, \frac{3a}{2}\right)$.

Course Outcome 4 (CO4)

1. Predict the evolute of the parabola $x^2 = 4ay$.
 2. Predict the envelope of the straight line $\frac{x}{a} + \frac{y}{b} = 1$, where a and b are parameters that are connected by the relation $a+b=c$.
 3. Is it possible to find the curvature of a straight line? Justify your answer.

Course Outcome 5 (CO5)

1. Examine the extrema of $f(x, y) = x^2 + xy + y^2 + \frac{1}{x} + \frac{1}{y}$.
 2. Identify the saddle point and the extremum points of $f(x, y) = x^4 - y^4 - 2x^2 + 2y^2$.
 3. Analyse the extrema of the function $f(x, y) = x^2 - 2xy + y^2 + x^3 - y^3 + x^4$ at the origin

Course Outcome 6 (CO6)

1. Apply Lagrangian multiplier method to find the shortest and the longest distances from the point (1,2,-1) to the sphere $x^2 + y^2 + z^2 = 24$.
 2. Exhibit the point on the curve of intersection of the surfaces $z=xy+5$ and $x+y+z=1$ which is nearest to the origin.
 3. The temperature at any point (x,y, z) in a space is given by $T = kxyz^2$, where k is a constant. Find the highest temperature on the surface of the sphere $x^2 + y^2 + z^2 = a^2$.

Course Outcome 7 (CO7)

1. Solve the equation $y'' + a^2y = \tan ax$ by the method of variation of parameters.
2. Compute the solution of the given equation $(x^2D^2 - 2xD - 4)y = 32(\log x)^2$.
3. Predict the solution of $((2x+3)^2D^2 - 2(2x+3)D - 12)y = 6$.
4. Solve the simultaneous equations $x'+2x - 3y = 5t$, $y'-3x+2y = 2e^{2t}$.

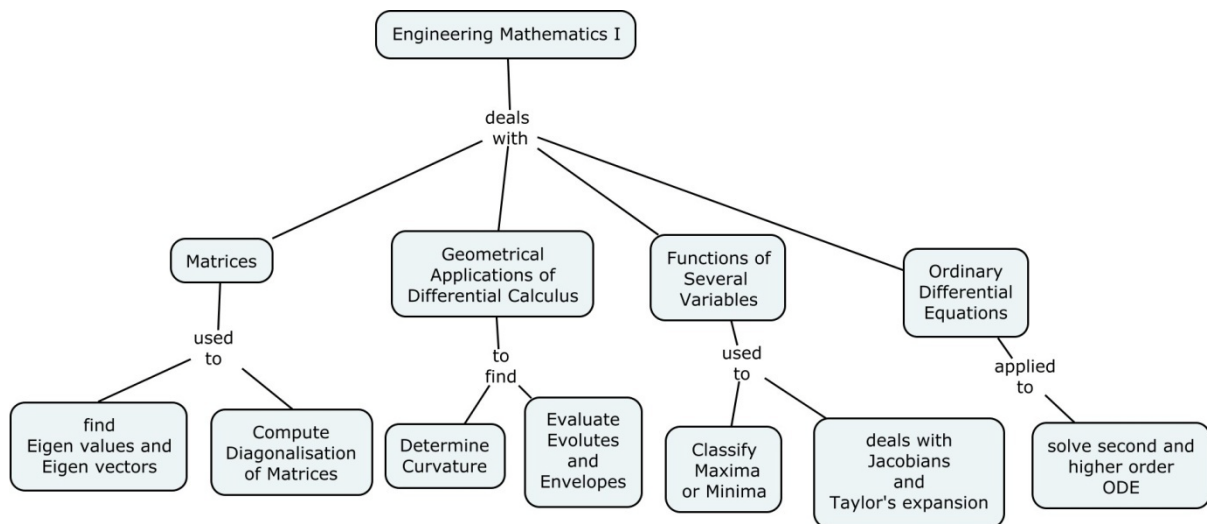
Concept Map**Syllabus**

MATRICES: Characteristic equation – Eigen values and Eigen vectors of a real matrix – Properties of Eigen values –Cayley Hamilton theorem- Orthogonal reduction of a symmetric matrix to diagonal form –Orthogonal matrices –Reduction of quadratic form by orthogonal transformation, Applications.

GEOMETRICAL APPLICATIONS OF DIFFERENTIAL CALCULUS: Curvature – Cartesian and Polar coordinates – Centre of curvature, Circle of curvature – Evolutes and Envelopes, Applications.

FUNCTIONS OF SEVERAL VARIABLES: Function of two variables – Partial derivatives – Total derivative – Change of Variables - Jacobians - Taylor's expansion – Maxima and Minima – Constrained Maxima and Minima by Lagrangian Multiplier method, Applications.

ORDINARY DIFFERENTIAL EQUATIONS: Linear differential equations of second and higher order with constant coefficients - Method of variation of parameters – Equations reducible to linear equations with constant coefficients: Cauchy's homogeneous linear equation and Legendre's linear equation - Simultaneous linear equations with constant coefficients. Applications.

Text Book

1. Kreyszig.E, "Advanced Engineering Mathematics", John Wiley & Sons. Singapore, 10thedition, 2012.
2. Grewal.B.S, Higher Engineering Mathematics, Khanna Publications, 42nd Edition, 2012.

Reference Books

1. Veerarajan.T, "Engineering Mathematics I", Tata McGraw Hill Publishing Co, New Delhi, 5th edition, 2006.
2. Kandasamy .P et.al. "Engineering Mathematics", Vol.I (4th revised edition), S.Chand &Co, New Delhi, 2000.

Course Contents and Lecture Schedule

Module No.	Topic	No.of Lectures
1	MATRICES	
1.1	Characteristic equation – Eigen values and Eigen vectors of a real matrix	2
1.2	Properties of Eigen values	1
	Cayley Hamilton theorem	2
	Tutorial	1
1.3	Orthogonal reduction of a symmetric matrix to diagonal form	2
1.4	Orthogonal matrices –Reduction of quadratic form by orthogonal transformation.	1
1.5	Applications	1
	Tutorial	1
2	GEOMETRICAL APPLICATIONS OF DIFFERENTIAL CALCULUS	
2.1	Curvature – Cartesian and Polar co-ordinates	2
2.2	Centre of curvature, Circle of curvature	2
	Tutorial	1
2.3	Evolutes	2
2.4	Envelopes.	2
2.5	Applications	1
	Tutorial	1
3	FUNCTIONS OF SEVERAL VARIABLES	
3.1	Function of two variables – Partial derivatives	1
3.2	Total derivative	1
	Tutorial	1
3.3	Change of Variables ,Jacobians	2
3.4	Taylor's expansion	1
3.5	Maxima and Minima	2
3.6	Constrained Maxima and Minima by Lagrangian Multiplier method	2
3.7	Applications	1
	Tutorial	1
4	ORDINARY DIFFERENTIAL EQUATIONS	
4.1	Linear differential equations of second and higher order with constant coefficients.	2
	Tutorial	1
4.2	Cauchy's homogeneous linear equation	1
4.3	Legendre's linear equation	1
4.4	Method of variation of parameters	1
4.5	Simultaneous linear equations with constant coefficients.	2
4.6	Applications	1
	Tutorial	1
	Total	44

Course Designers:

- | | | |
|----|-------------------------|--------------------|
| 1. | P. Subramanian | psmat@tce.edu |
| 2. | V. Gnanraj | vgmat@tce.edu |
| 3. | S. Jeya Bharathi | sjbmat@tce.edu |
| 4. | G Jothilakshmi | gjmat@tce.edu |
| 5. | A.P.Pushpalatha | appmat@tce.edu |
| 6. | M.Sivanandha Saraswathy | sivanandha@tce.edu |

Category L T P Credit

BS 3 0 0 3

14PH120 PHYSICS**Preamble**

The course work aims in imparting fundamental knowledge of thermodynamics, quantum physics and optics which are essential in understanding and explaining engineering devices and measuring instruments. The objective of the course is to help students acquire a basic knowledge for thermal applications, electron microscopy techniques and fibre optic communication systems.

Prerequisite

NIL

Course Outcomes

On the successful completion of the course, students will be able to

Assessment Pattern

CO1: Compute the theoretical efficiency of a Carnot's engine	Apply
CO2: Calculate the change in entropy in a thermal cycle	Apply
CO3: Explain the basic concept of quantum theory	Understand
CO4: Describe the working principle of SEM and TEM	Understand
CO5: Compare and contrast the properties and applications of laser and ordinary incandescent light	Analyse
CO6: Illustrate the principle of light transmission in a fibre and compare its advantages as a wave guide over the conventional co-axial cable	Analyse
CO7: Explain the basic principle, construction and working of optical fibre sensor	Understand

Bloom's Category	Continuous Assessment Tests			Terminal Examination
	1	2	3	
Remember	10	10	10	10
Understand	30	30	30	30
Apply	40	40	40	40
Analyse	20	20	20	20
Evaluate	0	0	0	0
Create	0	0	0	0

Course Level Assessment Questions**Course Outcome 1 (CO1):**

- Show that the efficiency of an ideal heat engine depends only on the temperature of the source and sink.
- Compute the efficiency of a Carnot's engine working between the steam point and the ice point.
- A Carnot's engine is operated between two reservoirs at temperature of 450K and 350K. If the engine receives 1000 calories of heat from the source in each cycle. Calculate the amount of heat rejected to the sink and work done by the engine in each cycle.

Course Outcome 2 (CO2):

1. Compute the change in entropy when 5 kg of water at 100°C is converted into steam at the same temperature. (Latent heat of vaporisation=540cal/g)
2. Show that the area of the temperature-entropy diagram of a Carnot's cycle is the useful work done per cycle.
3. One mole of a gas expands isothermally to four times its volume. Calculate the change in entropy in terms of gas constant.

Course Outcome 3 (CO3):

1. Describe Planck's law of black body radiation.
2. Summarize the physical significance of wave function.
3. Explain Compton Effect and derive an expression for the wavelength of the scattered photon.

Course Outcome 4 (CO4):

1. Explain the construction and working of TEM.
2. Explain the wave-particle duality of matter and obtain an expression for de Broglie wavelength.
3. Describe the construction and working of SEM.

Course Outcome 5 (CO5):

1. Find the ratio of population of two energy states in a Laser, the transition between which is responsible for the emission of photons of wavelength 6893A at a temperature of 300K. Comment on the type of emission based on the ratio of population.
2. Analyse the role of mixture of gases for a CO₂ laser and predict the working of the laser without Helium gas in the mixture.
3. Differentiate between CO₂ laser and NdYAG Laser with respect to their construction and energy level diagram.

Course Outcome 6 (CO6):

1. Compare and contrast the material properties of core and cladding
2. Identify the major advantages of optical fibre communication system over conventional communication systems
3. Draw the refractive index profile of step index and graded index fibres and comment on the advantages of graded index fibre based on refractive index profile.

Course Outcome 7 (CO7)

1. Define a sensor with an example.
2. Explain the classification of fibre optic sensors based on their working principle.
3. Explain the principle and working of temperature sensor

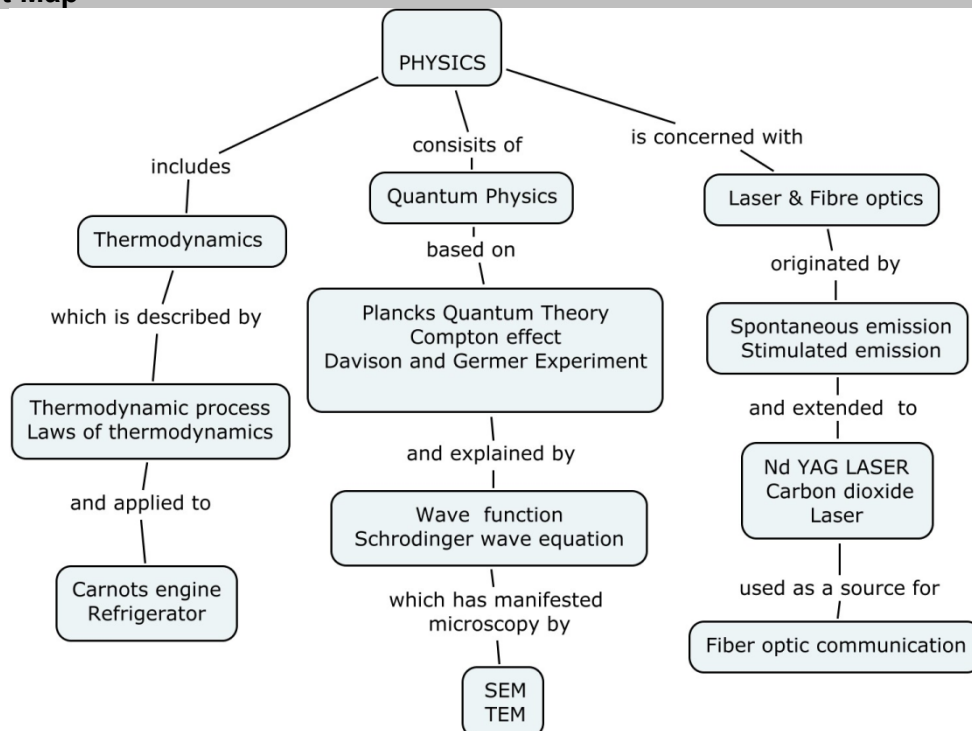
Concept Map**Syllabus****Thermodynamics**

Introduction to thermodynamics-Thermodynamic process-Work done in isothermal and adiabatic process- First and second law of thermodynamics- Carnot's engine-Refrigerator, Temperature-Entropy diagram-Change in entropy in reversible and irreversible process-Entropy of a perfect gas. Application: Otto cycle- Internal Combustion engine.

Quantum Physics

Planck's quantum theory of blackbody radiation-Compton effect-De-Broglie Hypothesis-Davison & Germer experiment-wave function and its properties-Uncertainty principle-Schrodinger wave equation-Time dependent and time independent equations-particle in a box.

Application: Scanning Electron Microscope-Transmission Electron Microscope

Laser and Fibre Optics

Fundamentals of laser-Spontaneous and Stimulated emission-Laser action-characteristics of laser beam-Einstein coefficients-Nd-YAG laser, CO₂ laser-applications of laser- Holography Fibre Optics-Principle and propagation of light in Optical fibre-Numerical aperture-Acceptance angle-Classification of Optical fibre based on material, refractive index and mode-Fibre Optic communication system.

Application: Fibre Optic sensors- temperature, and displacementsensors.

Text Book

1. Paul G Hewitt, "Conceptual Physics", 12th Edition Pearson Higher Education Pvt. Ltd., 2014.
2. Gour R.K. and Gupta S.L., "Engineering Physics", 8th Edition Dhanpat Rai Publications, 2006

Reference Books

1. Arthur Beiser, " Concepts of Modern Physics", McGraw Hill Education(India)Pvt Limited, 6th Edition, 2003
2. Stephen Blundell, "Concepts in Thermal Physics", Oxford University Press, 2nd Edition 2010.
3. Gerd keiser, " Optical fiber communications", Tata Mc Graw Hill Pvt Ltd, 4th Edition 2008.

Course Contents and Lecture Schedule

Module No.	Topic	No. of Lectures
1.	Thermodynamics	
1.1	Introduction to thermodynamics-Thermodynamic processes	2
1.2	Work done in isothermal and adiabatic process	2
1.3	First and second law of thermodynamics	2
1.4	Carnot's engine- theoretical efficiency expression-Refrigerator	2
1.5	Temperature-Entropy diagram	1
1.6	Change in entropy in reversible and irreversible process	2
1.7	Entropy of a perfect gas	2
1.8	Application: Otto cycle- Internal Combustion engine.	2
2.	Quantum Physics	
2.1	Planck's quantum theory of blackbody radiation	2
2.2	Compton effect- derivation	3
2.3	Davisson & Germer experiment	2
2.4	Wave function and its properties-Uncertainty principle	2
2.5	Schrodinger wave equation-Time dependent and time independent equations	2
2.6	Particle in a box - Problems	2
2.7	Application: Scanning Electron Microscope-Transmission Electron Microscope	2
3.	Laser and Fibre Optics	
3.1	Fundamentals of laser, Spontaneous and Stimulated emission	1
3.2	Laser action-characteristics of laser beam	2
3.3	Einstein coefficients	1
3.4	Nd-YAG laser	1
3.5	CO ₂ laser	1
3.6	Applications of laser- Holography	1
3.7	Principle and propagation of light in Optical fibre	1
3.8	Numerical aperture-Acceptance angle	2
3.9	Classification of Optical fibre based on material, refractive index and mode	2
3.10	Fibre Optic communication system	1
3.11	Application: Fibre Optic sensors- temperature, and displacementsensor	2

Total **42**

Course Designers:

- | | |
|-------------------------|----------------|
| 1. Dr.R.Vasuki | rvphy@tce.edu |
| 2. Mr. A.L.Subramaniyan | alsphy@tce.edu |
| 3. Mr. D.Ravindran | drphy@tce.edu |

14CH130 CHEMISTRY

Category	L	T	P	Credit
BS	3	0	0	3

Preamble

The objective of this course is to bestow better understanding of basic concepts of chemistry and its applications on diverse engineering domains. It also imparts knowledge on properties of water and its treatment methods, Engineering materials and its protection from corrosion, Energy storage technologies, properties of fuels and combustion. This course also highlights criteria behind selecting materials for various engineering applications and their characterization.

Prerequisite

NIL

Course Outcomes

On the successful completion of the course, students will be able to

CO 1. Estimate the hardness of water	Apply
CO 2. Identify suitable water treatment methods	Analyze
CO 3. Describe the components and working of energy storage devices	Understand
CO 4. Illustrate control methods for various forms of corrosion	Apply
CO 5. Enumerate the quality of fuels from its properties	Remember
CO 6. Outline the important features of fuels	Analyze
CO 7. Select appropriate materials for specific applications	Apply

Assessment Pattern

Bloom's Category	Continuous Assessment Tests			Terminal Examination
	1	2	3	
Remember	20	20	20	20
Understand	40	30	30	30
Apply	40	40	40	40
Analyze	0	10	10	10
Evaluate	0	0	0	0
Create	0	0	0	0

Course Level Assessment Questions**Course Outcome 1 (CO1):**

1. Differentiate temporary and permanent hard water.
2. 50 ml of given water sample consumed 18 ml of EDTA during titration using EBT indicator. 25 ml of same EDTA consumed by 50 ml of standard hard water containing 1 mg of pure CaCO_3 per ml. Calculate the hardness of given water samples in ppm.
3. Describe the essential characteristics of drinking water.

Course Outcome 2 (CO2):

1. Compare the mechanisms involved in ion exchange and zeolite methods of water treatment.
2. Appraise the treatment steps followed in municipal water supply.
3. Criticize the internal treatment methods of water.

Course Outcome 3 (CO3):

1. Describe the working of lithium ion battery with the help of electrode reactions.
2. Demonstrate the advantages of fuel cell over conventional batteries.
3. Explain the types of battery.

Course Outcome 4 (CO4)

1. Illustrate the different forms of corrosion
2. Collect and explain the factors which influence the corrosion.
3. Exhibit the various forms of corrosion control methods

Course Outcome 5 (CO5)

1. Define the calorific value of the fuel
2. Describe the cetane and octane numbers of the fuel.
3. List the characteristics of good fuel

Course Outcome 6 (CO6)

1. Assess the quality of coal by performing proximate and ultimate analysis
2. Calculate the minimum volume of air required for the complete combustion of 1 m³ of gaseous fuel containing the following composition by volume. CO: 23%; H₂:12%; CH₄: 3%; CO₂: 5%; N₂: 55%; and O₂: 2%.
3. Compare: Liquefied petroleum gas and bio gas.

Course Outcome 7 (CO7)

1. Explicate the characteristics of good refractory material.
2. Demonstrate the preparation of nano materials by sol-gel method.
3. Exhibit the applications of polymer composites.

Concept Map

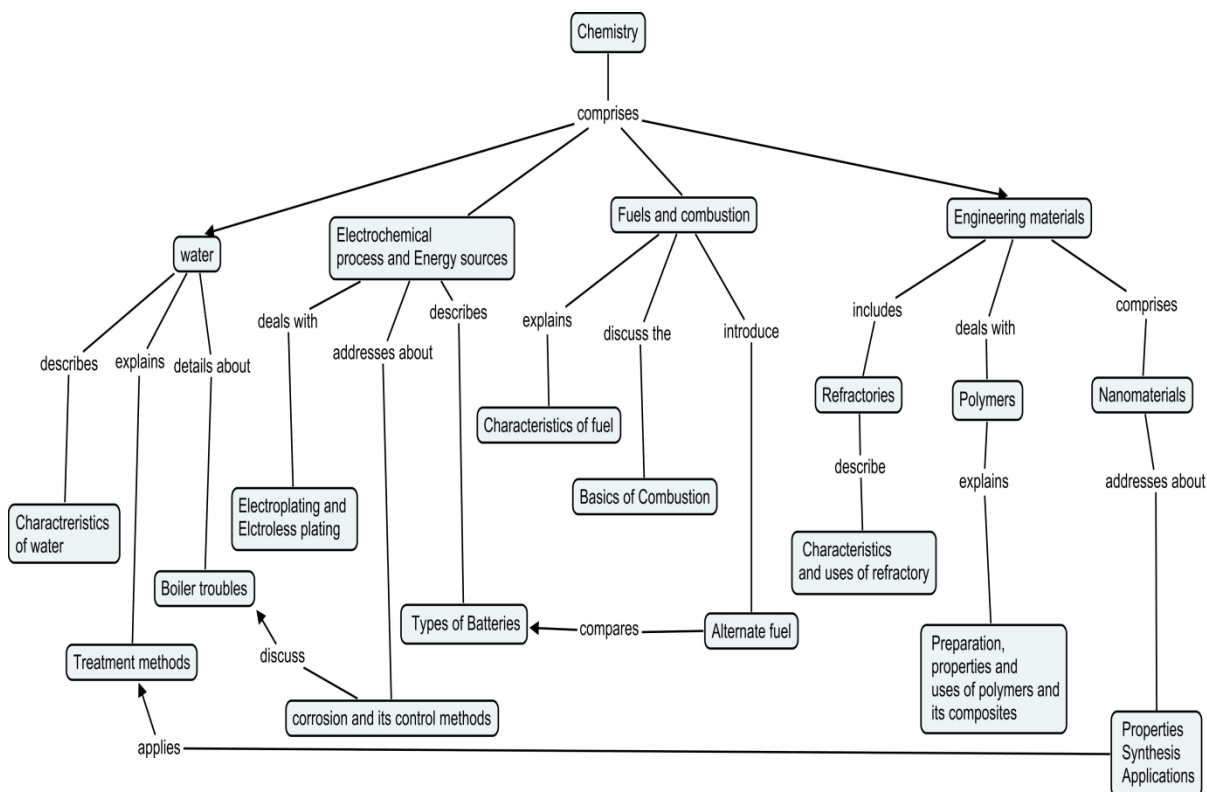

Syllabus

WATER: Standards for drinking water, Hardness. Softening of water: External and Internal treatments of water, Boiler troubles, Methods of treatment of municipal water .

ELECTROCHEMICAL PROCESSES AND ENERGY SOURCES: Introduction -Electroplating – Principle- Significant parameters and applications-PCB manufacturing- Electroless plating.**Batteries** –Primary and secondary batteries – Characteristics- Examples. Fuel cells - Classification and working principles. **Corrosion:** Principle-types- forms and control methods.

FUELS AND COMBUSTION: Fuels-Introduction- classification of fuels- calorific values - analysis of coal. **Combustion** –principle- calculation of fuel and air ratio- knocking characteristics - flue gas analysis –gaseous fuels - alternate fuels.

ENGINEERING MATERIALS: Refractories: Definition, characteristics, classification, properties-requisites of good refractory and their uses –**Polymers:** classification-Industrially important polymers – PE, PET, PVC – PU – nylon – epoxy resins – Bakelite-preparation properties and uses-conducting polymer-bio-polymer-polymer composites-**Nanomaterials:** Size-dependent properties – synthesis by physical and chemical methods –applications-future perspectives.

Text Book

1. Jain & Jain, “ Engineering Chemistry”, Dhanpat Rai publishing Company (P) Ltd, NewDelhi, 15th Edition, 2008.

Reference Books

1. S.S. Dara and S.S.Umare, “A Textbook of Engineering Chemistry”, S.Chand & Company, 12th Edition, Reprint, 2013.
2. V R Gowariker, N V Viswanathan and Jayadev Sreedhar, “Polymer Science” New age International Publisher, 2012.
3. Charles P.Poolejr and Frank J.Owens, “Introduction to Nanotechnology”, Wieli-India, 2008.

Course Contents and Lecture Schedule

Module No.	Topic	No. of Lectures
1.0	Water	
1.1	Introduction: importance of water, standards for drinking water, physical, chemical & biological parameters. (WHO, BIS & ICMR standards)	1
1.2	Alkalinity (principle only) ,Hardness of water – types, units,	1
1.3	Determination of hardness by EDTA method and problems	2
1.4	Softening of water: External treatment methods: Lime-soda process (concept only), zeolite process,	1
1.5	ion exchange process, reverse osmosis, electro dialysis	2
1.6	Solar and multistage flash distillation , nanofiltration	1
1.7	Boiler trouble: scale and sludge formation, boiler corrosion, priming and foaming, caustic embrittlement,	2
1.8	Internal treatment methods: Carbonate, Phosphate, Colloidal, Calgon conditioning,	1
1.9	municipal water treatment	1
2.0	Electrochemical process and Energy sources	
2.1	Electrochemistry- introduction-Electroplating- Definition, Principles- Significant parameters	2
2.2	Nickel and Chromium electroplating	1
2.3	Electroless plating –PCB manufacturing	1
2.4	Corrosion- definition, mechanism, forms of corrosion	2

Module No.	Topic	No. of Lectures
2.5	Factors influencing corrosion and corrosion control methods	2
2.6	Batteries- Definition, types-dry cell, lead acid and lithium batteries	2
2.7	Fuel cells- principle, types and applications. (H ₂ O ₂ fuel cell)	1
3.0	Fuels and combustion	
3.1	Introduction- Classification of fuels	1
3.2	Calorific Values- Theoretical calculation using Dulong's formula	1
3.3	Coal – classification- Analysis of coal- Proximate and Ultimate analysis	2
3.4	Refining of petroleum- Knocking characteristics-Octane and Cetane numbers	1
3.5	Natural gas- Liquefied petroleum gas- producer gas-bio gas- alternate fuels- power alcohol- bio diesel	2
3.6	Combustion- calorific intensity- SIT- Calculation of minimum quantity of air required for combustion	2
3.7	Flue gas analysis	1
3.8	Gaseous fuels	1
3.9	Alternate fuels	1
4.0	Engineering materials	
4.1	Refractories: Definition-physical and chemical characteristics- classification, properties-requisites of good refractory and their uses	2
4.2	Polymers: classification-Industrial important polymers – PE, PET, PVC – PU– nylon – epoxy resins- Bakelite- preparation properties and uses	2
4.3	conducting polymer mechanism -bio-polymer-polymer composites	1
4.4	Nanomaterials: Size-dependent properties – synthesis by physical (laser ablation, PVD) and	2
4.5	chemical methods (solgel, hydro thermal) - applications-future perspectives	2
Total number of Lectures		44

Course Designers:

- | | | |
|----|---------------------|-----------------------------|
| 1. | Dr.K.Radha | hodchem@tce.edu |
| 2. | Dr. M.Kottaisamy | mmksami@tce.edu |
| 3. | Mrs.J.Shanmugapriya | shanmugapriya@tce.edu |
| 4. | Mr.S.Rajkumar | rajkumarsubramaniam@tce.edu |

14EG141 ENGLISH

Category	L	T	P	Credit
HSS	3	1	0	3

Preamble

This is a life skill course necessary for all students of Engineering and Technology. The course work aims at developing communication skills in English essential for understanding and expressing the ideas in different social, academic and professional contexts. The outcome of the course is to help the students acquire the language skills of listening, speaking, reading and writing competency in English language thereby making them competent and employable in the globalised scenario.

Prerequisite

NIL

Course Outcomes

On the successful completion of the course, students will be able to

- | | |
|--|------------|
| CO1. listen, understand and respond to others in different situations | Understand |
| CO2. speak correctly and fluently in different situations using appropriate communication strategies. | Apply |
| CO3. read and comprehend a variety of texts adopting different reading skills | Understand |
| CO4. write with clarity in simple, apt and flawless language with coherence and cohesion | Apply |
| CO5. use their communicative competency with precision and clarity in the context of science and technology | Understand |
| CO6. be interpersonal and proactive in using language confidently and effectively for personal and profession growth | Create |

Assessment Pattern

Bloom's Category	Continuous Assessment Tests			Terminal Examination
	1	2	3	
Remember	20	20	20	20
Understand	40	40	40	40
Apply	20	20	20	20
Analyse	-	-	-	-
Evaluate	-	-	-	-
Create	20	20	20	20

Course Level Assessment Questions**Course Outcome 1 (CO1):**

1. Tested by way of assignments like – listening to short speeches of contexts - general and technical
2. Answering questions – objective and descriptive
3. Note taking

Course Outcome 2 (CO2):

1. Tested by way of assignments like role play, mini presentation, self-introduction, situational conversation and one-to-one debate
2. Write down an imaginary dialogue between a father and a son about his/her fresh college experience. (in five exchanges, not more than 150 words)

3. Choose the right option that at best fits in the blanks (Mention A or B or C or D only)

They are to ____ a question paper to identify the moral ____ of the young candidates.

A. /prɪvɪnt/-/kærɪktəʳ/ B. /sɛt/-/kəndɪ kt/ C. /prɪpeəʳ/-/kəndɪ kt/ D. /prezəns/-/kəʊd/

4. Read the following phonemic sentence and answer the question below:

/ðeəʳ ɪz nəʊ klɒk ɪn ðə klɑ :sru:m/

What is unavailable in the learning place?

Course Outcome 3 (CO3):

1. Read the following passage and answer the following questions.

A passage from the context of science and technology/current issues will be given followed by different types of questions/exercises like:

- Descriptive questions for eliciting short answers
- True or False
- Sentence Completion
- Objective type
- Synonyms /meaning of the words in the text

2. Read the passage given under Q.No. 1a and 'make notes' (Not exceeding 100 words).

3. Read the passage given under Q.No.1a and write a summary (Not exceeding 100 words).

Course Outcome 4 (CO4):

1. Rewrite the following sentence using the appropriate modal auxiliary

The variation in reading is to be noted down every minute compulsorily for the first five minutes.

2. Expand the nominal compounds: 1. Credit Card 2. Newspaper Glasses

3. Complete the following: The function of a mini drafter -----

4. What is meant by a topic sentence?

5. Write a set of recommendations to save electric power.

Course Outcome 5 (CO5):

1. Analyse and interpret the following graphic data in about 100 words:

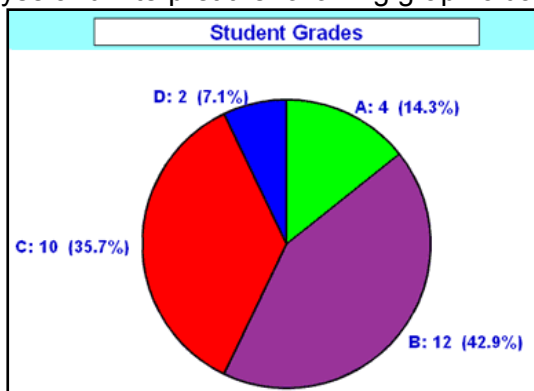

2. Write a basic definition of an MP3 player.

3. Establish cause and effect relationship for the following:

The trade imbalance is likely to rise again in 2015. A new set of policy actions will be required soon.

Course Outcome 6 (CO6):

1. Write a letter to the HR Manager, TCS, Chennai, requesting him to grant permission for your In-plant Training during your summer vacation.

2. Write a paragraph in about 100 words on "The Impact of Technology on Nature"

3. Prepare a set of 10 instructions on how to draw money from an ATM.

Concept Map

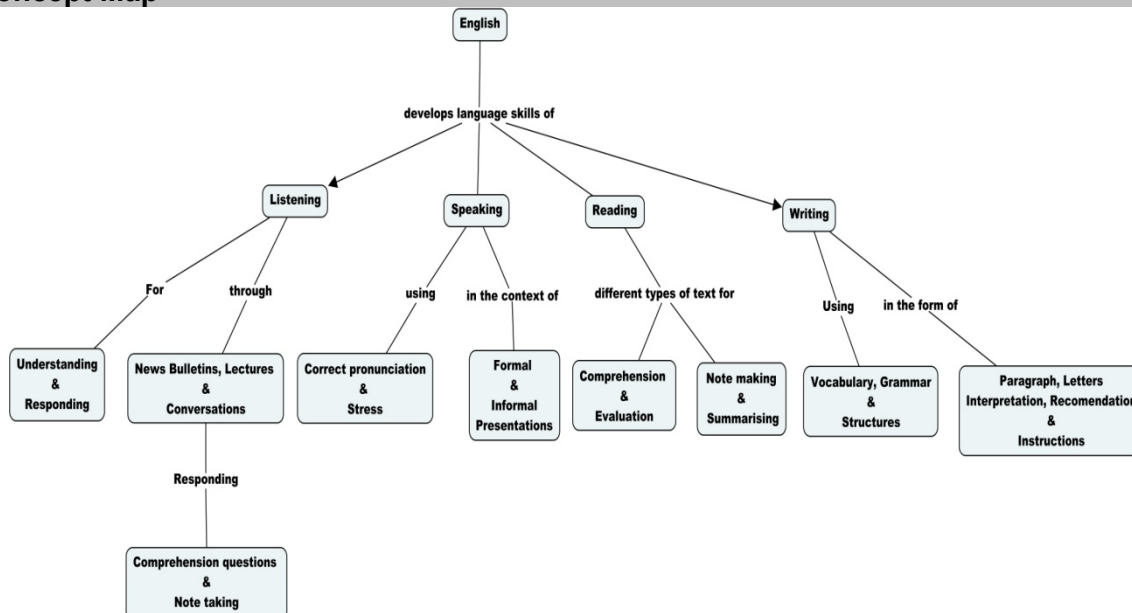

Syllabus

Listening

Listening to news bulletins, lectures and conversations; answering comprehension questions; active listening; note-taking

Speaking

Pronunciation, Syllable and Stress; Contracted forms, Courtesy words; Situational conversation, One-to one debate and Mini presentation on extensive reading and Dailies.

Reading

Skipping, Scanning and Skimming; Reading for information and pleasure; Study skills – Comprehension, Note-making and Summarising

Writing

Vocabulary : Word analysis, Parts of Speech (Nouns, Verbs, Adjectives, Adverbs Articles, Prepositions, Conjunctions); Sentences Types (Affirmative, Negative, Interrogative, Imperative, Exclamatory) ; Sentence Structure (Subject Verb Agreement, Tenses, Voices, Modals, Conditionals, Relative clauses, Reported Speech); Dialogue Writing, Notions (Nominal Compounds, Definition, Classification, Cause and Effect, Purpose and Function) Paragraph Writing: Compare and Contrast, Descriptive; Formal Letters; Interpretation of Graphics; Instructions and Recommendations.

Text Book

Workbook prepared by the Department of English

Reference Books

1. Department of English, Anna University, Mindscapes: English for Technologists and Engineers, Orient Blackswan, Chennai, 2012
2. Dhanavel, S.P. English and Communication Skills for Students of Science and Engineering, Orient Blackswan, Chennai, 2011
3. Murphy, Raymond English Grammar in Use with Answers: Reference and Practice for Intermediate Students, Cambridge : CUP, 2004
4. Jones, Daniel. An English Pronouncing Dictionary, Cambridge: CUP, 2006
5. Prasad, Hari Mohan , Sinha, Uma Rani , Objective English for Competitive Examinations, Tata McGraw-Hill: Noida, 2010
6. Thomson, A.J. and Martinet, A.V. A Practical English Grammar, OUP, New Delhi:1986
7. Lewis, Norman, Word Power Made Easy, Goyal Publishers, New Delhi: 2004

Course Contents and Lecture Schedule

Module No.	Topic	No. of Lectures
1.	Introduction	1
2.	Listening to News, Lectures, Conversations - Practice	1
3.	Comprehension Exercises	1
4.	Active Listening and Note-taking	1
5.	Introduction to Phonemes	1
6.	Syllables and Stress	1
7.	Contracted Forms, Courtesy Words	1
8.	Situational Conversation, Telephonic Conversation	1
9.	Reading - Skimming, Skipping and Scanning	1
10.	Note Making and Summarizing	1
11.	Dialogue Writing	1
12.	Vocabulary - Word Analysis, Parts of Speech	1
13.	Types of Sentences	1
14.	Tutorial	1
15.	Presentation Skills (Activity)	2
16.	Reading Comprehension	2
17.	Subject Verb Agreement	1
18.	Tenses	2
19.	Voices	1
20.	Modals	1
21.	Conditions	1
22.	Relative Clause	1
23.	Reported Speech	1
24.	Formal Letter Writing	1
25.	Instruction Writing	1
26.	Tutorial	1
27.	Nominal Compounds	1
28.	Definition and Classification	1
29.	Cause and Effect	1
30.	Purpose and Function	1
31.	Paragraph Writing	2
32.	Recommendation Writing	1
33.	Interpretation of Graphics	2
34.	Spoken Assignment	3
35.	Tutorial	1
36.	Revision	2
37.	Feedback	1
	Total	45

Course Designers:

1	Dr.T.Sadasivan	sadasivan@tce.edu
2	Dr.S.Rajaram	sreng@tce.edu
3	Dr.A.Tamilselvi	tamilselvi@tce.edu
4	Mr.Vinoth.R	vino@tce.edu
5	Ms.R.K.Jaishree Karthiga	jai@tce.edu

14ES150

**BASICS OF CIVIL AND
MECHANICAL ENGINEERING**

Category	L	T	P	Credit
ES	2	0	0	2

A. BASICS OF CIVIL ENGINEERING**Preamble**

This course will create awareness on fundamental knowledge on various domains of Civil Engineering

Prerequisite

- NIL

Course Outcomes

On the successful completion of the course, students will be able to:

CO1:	Identify the branches of Civil Engineering and roles of a Civil Engineer	Understand
CO2:	Explain the properties and uses of building materials, Concept of green building	Understand
CO3:	Identify and explain the functions of various components of a residential building and building safety devices	Understand
CO4:	Explain the properties and classifications of soils and appropriate foundation for different soil conditions	Understand
CO5:	Identify the various sources of water and need for rain water harvesting	Understand
CO6:	Explain the various stages of works involved in water supply and sewerage projects.	Understand
CO7:	Classify roads and explain the importance of signalling	Understand

Assessment Pattern

Bloom's Category	Continuous Assessment Tests			Terminal Examination
	1	2	3	
Remember	20	20	--	20
Understand	30	30	--	30
Apply	---	---	---	---
Analyse	---	---	---	---
Evaluate	---	---	---	---
Create	---	---	---	---

CAT 3 – ASSIGNMENT (GROUP PRESENTATION)**Course Level Assessment Questions****Course Outcome 1 (CO1):**

1. List the various branches of Civil Engineering
2. Compare the roles of Structural and Environmental Engineers
3. Discuss the various functions of a Civil Engineer

Course Outcome 2 (CO2):

1. Discuss the properties of a building stone
2. Mention the types of cement
3. Compare PCC and RCC and mention the applicability of each

Course Outcome 3 (CO3)

1. Draw the cross section through a wall and explain the functions of various components
2. Compare arches and lintels
3. Write the purpose of DPC in buildings

Course Outcome 4 (CO4)

1. Define foundation and mention its various types
2. Enumerate the various engineering properties of soil
3. Explain the situations requiring deep foundations.

Course Outcome 5 (CO5)

1. Explain the various sources of water
2. Draw and explain the hydrological cycle
3. Write the need for preserving water, mentioning its methods

Course Outcome 6 (CO6)

1. Define per capita demand
2. Explain the necessity for treatment of water
3. Explain the need for sewerage

Course Outcome 7 (CO7)

1. Discuss the classification of roads
2. List the various modes of transportation
3. Write the need and importance for signalling in roads.

Concept Map

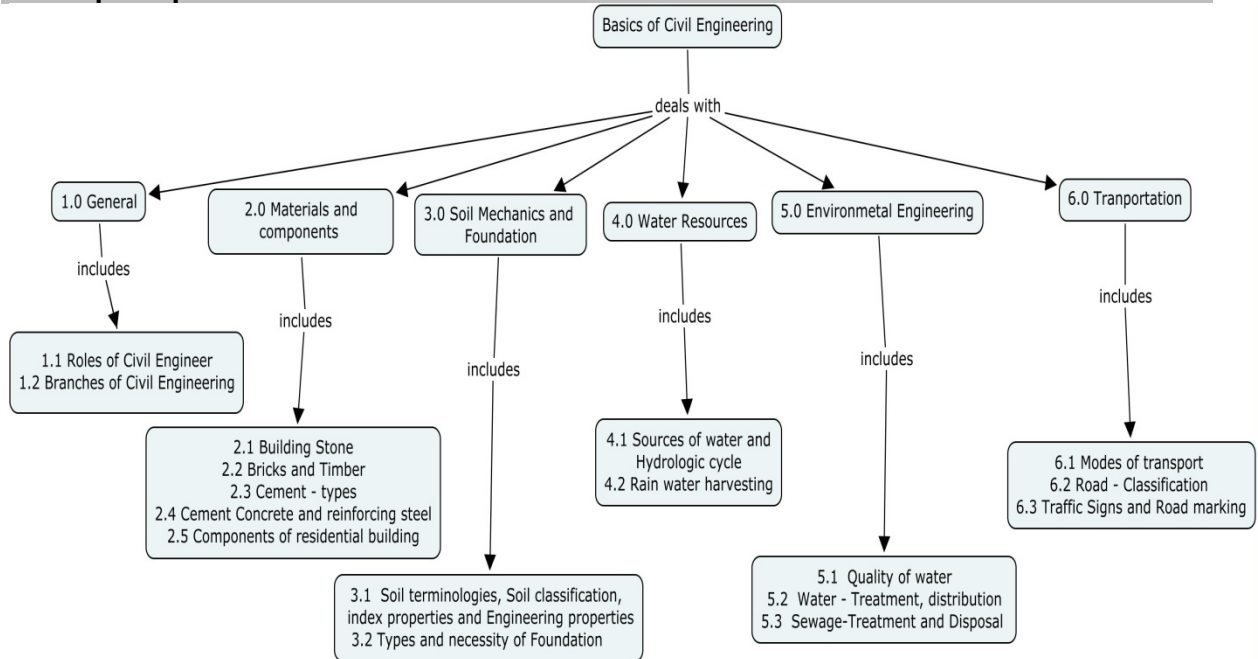

Syllabus

General: Introduction – Functions and role of Civil Engineer- Branches of Civil Engineering.

Materials and Components: Materials – Properties, classification and characteristics of building stones, bricks, timber, cement and cement concrete, reinforcing steel- Components of residential building. Green building concepts and building safety devices. **Soil Mechanics and Foundation:** Geological cycle – Soil classification –Engineering properties. Foundation – Types and necessity. **Water Resources:** Sources of water – Hydrologic cycle – Rain water harvesting – importance – methods of rain water harvesting. **Environmental Engineering-** Water demand estimation – Sources of water – Quality of water – Treatment of water- Water distribution. Sewerage – need and importance – collection, treatment and disposal of sewage – Septic tanks. **Transportation:** Modes of transport – types. Roads – Classification of rural and urban roads. Traffic signs and road marking – Traffic signals.

Text Book:

1. Lecture Notes prepared by TCE Civil Engineering Faculty

Reference Books

1. G.Shanmugam and M.S.Palanichamy, "Basics of Civil and Mechanical Engineering", Tata McGraw Hill Publishers, New Delhi, 2014
2. T. Jha and S.K. Sinha, "Construction and Foundation Engineering" , Khanna publishers, Delhi, 2003
3. Ahuja and Birdi, , "Fundamentals of Building Construction" Dhanpat Rai and sons Delhi, 2000
4. Rangwala and S.B.Patel, "Engineering materials", Charotar publishing house, Anand, 2002
5. S.K. Garg, "Water Supply Engineering", Khanna publishers, Delhi, 2005
6. S.K. Garg, "Sewage Disposal and Air Pollution Engineering", Khanna publishers, Delhi, 2005
7. Khanna and Justo, "Highway Engineering", New Chand and Bros, Roorkee, 2000

Course Contents and Lecture Schedule

Module No.	Topic	No. of Lectures
1.0	General	
1.1	Roles of Civil Engineer	1
1.2	Branches of Civil Engineering	
2.0	Materials and Components	
2.1	Building stone – properties, types, characteristics and uses	1
2.2	Bricks and timber - properties, types, characteristics and uses	1
2.3	Cement- properties, types, characteristics and uses	1
2.4	Cement concrete and reinforcing steel - properties and uses	
2.5	Components of residential buildings – purpose	2
3.0	Soil Mechanics and Foundation	
3.1	Geological Cycle- Soil classification, engineering properties	1
3.2	Types and necessities of foundation	1
4.0	Water Resources	
4.1	Sources of water and hydrologic cycle	1
4.2	Rain water harvesting- importance and methods	1
5.0	Environmental Engineering	
5.1	Water demand estimation, quality and treatment of water	1
5.2	Methods of water distribution	1
5.3	Sewerage- need and importance, collection, treatment and disposal-Septic tank	1
6.0	Transportation	
6.1	Modes of transport	1
6.2	Road classification	
6.3	Traffic signs and road marking	2
Total periods		16

Course Designers:

- | | | |
|----|-------------------|----------------|
| 1. | Dr. T. Vel Rajan | tciv@tce.edu |
| 2. | Dr. S. Nagan | snciv@tce.edu |
| 3. | Dr. R. Velkennedy | rvkciv@tce.edu |
| 4. | Dr. G. Chitra | gcciv@tce.edu |
| 5. | Dr. T. Baskaran | tbciv@tce.edu |
| 6. | Dr. R. Ponnudurai | rpciv@tce.edu |

B. BASICS OF MECHANICAL ENGINEERING

Preamble

Basic Mechanical Engineering gives the fundamental ideas in the areas of engineering design, manufacturing and thermal engineering. An engineer needs to understand the design procedures, manufacturing techniques and working principle of an engineering component.

Prerequisite

NIL

Course Outcomes

On successful completion of the course, students will be able to

CO1: Describe the steps involved in component design and transmission systems	Understand
CO2: Explain the manufacturing processes such as casting, forming, joining, and machining	Understand
CO3: Describe the Functions of Prime movers, working of IC engines and refrigerator	Understand
CO4: Explain the various safety practices in industries and personal protective elements	Understand

Assessment Pattern

Bloom's Category	Continuous Assessment Tests			Terminal Examination
	1	2	3	
Remember	40	40	Assignment evaluation	40
Understand	60	60		60
Apply				
Analyse				
Evaluate				
Create				

Course Level Assessment Questions

Course Outcome 1 (CO 1):

1. Describe the evolution of mechanical engineering
2. State the need for design
3. Define stress

Course Outcome 2 (CO 2):

1. What is rolling?
2. What is the need of metal joining
3. State the applications of casting.

Course Outcome 3 (CO 3):

1. State the function of prime mover.
2. Explain the vapour compression refrigeration system
3. Compare the two stroke and four stroke engine

Course Outcome 4 (CO 4):

1. State the various precautions are to be taken by the welder
2. Explain the various personal safety practices in industries with reference to OSHA

Concept Map

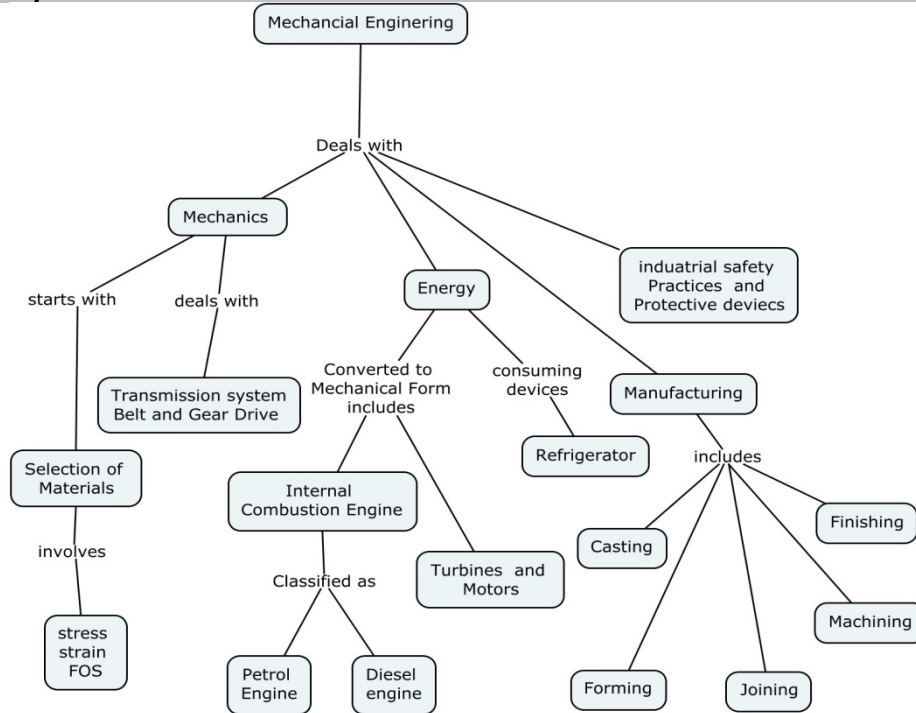

Syllabus

History and evolution of Mechanical Engineering

Steps of design procedure –Materials for engineering components, stress, strain, Factor of safety. Transmission systems- Belt and gear drives

Manufacturing processes – Types of manufacturing industries and manufacturing systems, foundry - green sand mould casting. Metal forming - forging, rolling, extrusion, drawing, Metal joining – Resistance Arc welding and Gas welding. Metal machining (construction and operation only) - lathe, metal finishing- Surface grinding

Energy resources - Renewable, Non renewable energy. Prime movers- Types and applications. Internal Combustion Engine- working of petrol, diesel engines, Domestic refrigerator – Vapour compression Refrigeration.

Industrial Safety practice & Protective Devices-General requirements- Eye and face protection.- Respiratory Protection - Head protection - Foot protection- Hand Protection.

Note: All the topics are to be taught / illustrated with product / component examples from domestic appliances (mixer, grinder, refrigerator, table, chair, cook wares, fan, bath tub, soap box, water tap, pin, clip), transports (bicycle, car, train, ship, aeroplane), Industrial components (gas stove burner, bolt, nut, window frame, gate, motor, pump, compressor, exhaust fan, nail, keys, table weight), etc

Assignments with power point presentation in other related topics like (not included for terminal examinations)

Different modes of heat transfer, Boilers, Pumps, Thermal, Wind, tidal, geothermal nuclear, Gas turbine power plants, Energy conservation, Alternate fuels, cryogenics, drilling operations, milling operations and surface finishing operations, Additive manufacturing.

Text Book

1. Basic Mechanical Engineering – Lecture notes by Dept. of Mechanical Engg., TCE,.
2. Shanmugam G and Palanichamy M S, “Basic Civil and Mechanical Engineering”, Tata McGraw Hill Publishing Co., New Delhi, 1996.
3. Prabhu.T.J, Jai Ganesh. V and Jebaraj.S, “Basic Mechanical Engineering”, Scitech Publications, Chennai, 2000.

Reference Books

1. Bhandari V B, "Design of Machine Elements", Tata McGraw hill Publications, Second edition, 2009.
2. Hajra Choudhury. S.K, Hajra Choudhury. A.K, Nirjhar Roy, “Elements of Workshop Technology”, Vol. 1, Media Promoters, 2009.
3. Venugopal K. and Prahua Raja V., “Basic Mechanical Engineering”, Anuradha Publishers, Kumbakonam, 2000.
4. Shantha Kumar S R J., “Basic Mechanical Engineering”, Hi-tech Publications, Mayiladuthurai, 2000.

Course Contents and Lecture Schedule

Module No.	Topic	No. of Lectures
1.0	History and evolution of Mechanical Engineering	1
2.0	Steps of design procedure – Materials for engineering components, stress, strain, Factor of safety	2
2.1	Transmission systems- Belt and gear drives	1
3.0	Manufacturing processes	
3.1	Types of manufacturing industries and manufacturing systems, foundry - green sand mould casting	1
3.2	Metal forming - forging, rolling, extrusion, drawing,	2
3.3	Metal joining – Resistance Arc and Gas welding	1
3.4	Metal machining (construction and operation only) - lathe	2
3.5	Metal finishing- Surface grinding	1
4.0	Energy resources - renewable, non renewable	1
4.1	Prime movers- Types and applications.	1
4.2	Internal Combustion Engine- Working of petrol, diesel engines	2
4.3	Domestic refrigerator – Vapour compression Refrigeration	1
5.0	Industrial Safety Practice & Protective Devices	1
6	Assignments with power point presentation	5
	Total no. of periods	22

Course Designers:

- | | | |
|----|-----------------------|----------------------|
| 1. | Dr. M. Kathiresan | umkathir@tce.edu |
| 2. | Mr. M. S. Govardhanan | govardhanans@tce.edu |

14ES160	BASICS OF ELECTRICAL AND ELECTRONICS ENGINEERING	Category	L	T	P	Credits
		ES	2	0	0	2

A. BASICS OF ELECTRICAL ENGINEERING**Preamble**

It is an introductory course which emphasize the fundamental concepts and overview of Electrical Engineering. The concepts discussed herein are intended to provide clarification on basic electrical engineering for beginners of all engineering graduates.

Prerequisite

NIL

Course Outcomes

On the successful completion of the course, the students will be able to:

CO1	Explain the evolution of electricity and list the inventors.	Remember
CO2	Explain the basic electrical quantities and laws.	Understand
CO3	Explain the types of electrical equipment, machines and its applications.	Understand
CO4	Show the tariff for a given load and energy consumption.	Understand
CO5	Explain the electrical safety issues and protective devices.	Understand
CO6	Explain the roles of authorities governing Indian Electricity.	Understand
CO7	Explain the concept of renewable and non renewable resources of power generation systems.	Understand

Assessment Pattern

Bloom's Category	Continuous Assessment Tests			Terminal Examination
	1	2	3	
Remember	10	10	Through Assignment and Seminar	10
Understand	40	40		40
Apply	0	0		0
Analyse	0	0		0
Evaluate	0	0		0
Create	0	0		0

Course Level Assessment Questions**Course Outcome 1:**

1. Name the invention of Benjamin Franklin in 1747.
2. List the names of inventors of electrical quantities.
3. Write the year of installation of first hydro electric power plant.

Course Outcome 2:

1. State Ohm's Law.
2. Define Power & Energy.
3. Differentiate DC and AC supply.

Course Outcome 3 :

1. List the types of electric machines.
2. Name the types of analog meters for measuring current & voltage.
3. List the applications of induction motor.

Course Outcome 4 :

1. Show the energy consumed per year by a load of 60 W operated for 5 hours a day.
2. Write the expression relating power and energy.
3. State the need of star rating for equipment.

Course Outcome 5:

1. Distinguish between circuit breaker and lightning arrester.
2. List the various types of electrical hazards.
3. List the few electrical safety devices.

Course Outcome 6 :

1. List the various authorities governing Indian electricity.
2. List the activities of TEDA.
3. State the role of Central Electricity Regulatory Commission.

Course Outcome 7 :

1. State the significances of renewable power generation.
2. List the sources of renewable power.
3. State the limitation of non renewable power generation.

Concept Map

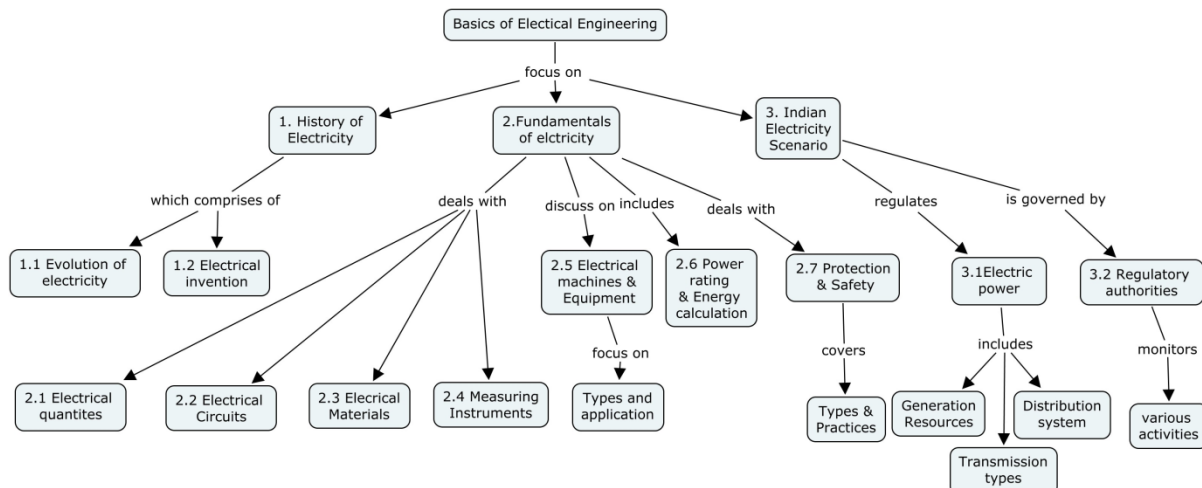

Syllabus

History of Electricity

Evolution of Electricity and Electrical inventions.

Fundamentals of Electricity

Electrical quantities- Charge, Electric potential, voltage, current, power, energy, DC, AC, time period, frequency, phase, flux, flux density, RMS, Average, Peak, phasor & vector diagram.

Electric Circuits - Passive components (RLC), Ohm's law, KCL, KVL, Faraday's law, Lenz's law.

Electrical materials – Conducting and insulating materials.

Measuring Instruments – Analog and Digital meters – Types and usage.

Electrical Machines & Equipment- Types, Specifications and applications.

Power rating and Energy calculation – for a sample load (domestic loads). Energy Efficient equipment – star ratings.

Protection & Safety - Hazards of electricity - shock, burns, arc-blast, Thermal Radiation, explosions, fires, effects of electricity on the human body. Electrical safety practices, Protection devices.

Indian Electricity Scenario

Electric Power- Generation resources, Transmission types & Distribution system (levels of voltage, power ratings and statistics)

Regulatory Authorities governing Indian Electricity - Roles of : MNRE,NTPC, NPCIL, PGCIL, APTEL, [CERC](#), SERC, CTU, STU, NLDC, RLDC,SLDC, RFO,BEE,TNEB, IREDA,TEDA.

Text Book

1. Basics of Electrical Engineering – Lecture Notes, Dept. of EEE, TCE, Madurai.

Course Contents and Lecture Schedule

Module No.	Topic	No. of Lectures
1.	History of Electricity	
1.1	Evolution of Electricity and Electrical inventions.	2
2.	Fundamentals of electricity	
2.1	Electrical quantities- Charge, Electric potential, voltage, current, power, energy, DC,AC, time period, frequency, phase, flux, flux density, RMS, Average, Peak, phasor & vector diagram.	2
2.2	Electrical circuits - Passive components (RLC), Ohm's law, KCL, KVL, Faraday's law, Lenz's law.	1
2.3	Electrical materials – Conducting and insulating materials.	1
2.4	Measuring Instruments- Analog and Digital meters – Types and usage	1
2.5	Electrical Machines & Equipment - Types, Specifications and applications.	2
2.6	Power rating and Energy calculation – for a sample load (domestic loads). Energy Efficient equipment – star ratings.	1
2.7	Protection & Safety - Hazards of electricity - shock, burns, arc-blast, Thermal Radiation, explosions, fires, effects of electricity on the human body. Electrical safety practices, Protection devices.	2
3.	Indian Electricity Scenario	
3.1	Electric Power- Generation resources, Transmission types & Distribution system (levels of voltage, power ratings and statistics).	2
3.2	Regulatory Authorities governing Indian electricity - Roles of : MNRE,NTPC, NPCIL, PGCIL, APTEL, CERC ,SERC, CTU, STU, NLDC, RLDC,SLDC, RFO,BEE,TNEB, IREDA,TEDA.	2
4	Assignments/Seminars: Evolution of Electrical Engineering, Electrical Equipment, Machines and its applications, Energy tariff calculation, Power generation, Protection devices, Indian Electricity Governance.	6
Total		22

Course Designers:

- | | | |
|----|-------------------|--|
| 1. | Mr.B.Ashok Kumar | ashokudt@tce.edu |
| 2. | Dr.S.Charles Raja | charlesrajas@tce.edu |
| 3. | Mr.G.Sivasankar | qsiva@tce.edu |
| 4. | Mr.V.Seetharaman | yseetharaman@tce.edu |

B.BASICS OF ELECTRONICS ENGINEERING

Preamble

Basic Electronics is a primary course for all engineering students. The course work aims in imparting fundamental knowledge on electronic components and communication engineering concepts. The objective of this course is to help students acquire knowledge in real life applications.

Prerequisite

NIL

Course Outcomes

On the successful completion of the course, students will be able to

CO1: Understand the basic electronic components	Understand
CO2: Identify Frequency Spectrum and Applications	Apply
CO3: Explain the operation of Communication blocks	Understand
CO4: Understand the applications of Electronics and Communication devices	Understand

Assessment Pattern

Bloom's Category	Continuous Assessment Tests			Terminal Examination
	1	2	3	
Remember	30	20	Assignment and Seminar	15
Understand	20	30		25
Apply	0	0		10
Analyse	0	0		0
Evaluate	0	0		0
Create	0	0		0

Course Level Assessment Questions

Course Outcome 1 (CO1):

1. Differentiate Electrical and Electronics.
2. Explain the operation of Diodes and Transistors.

Course Outcome 2 (CO2):

1. Explain different configurations of Transistors
2. Identify the frequency spectrum for mobile communications.

Course Outcome 3 (CO3):

1. Describe the operation of communication transceivers
2. Specify the types of communication systems.

Course Outcome 4 (CO4):

1. List different Real time Electronics Products.
2. Explain the concept behind satellite communication

Concept Map

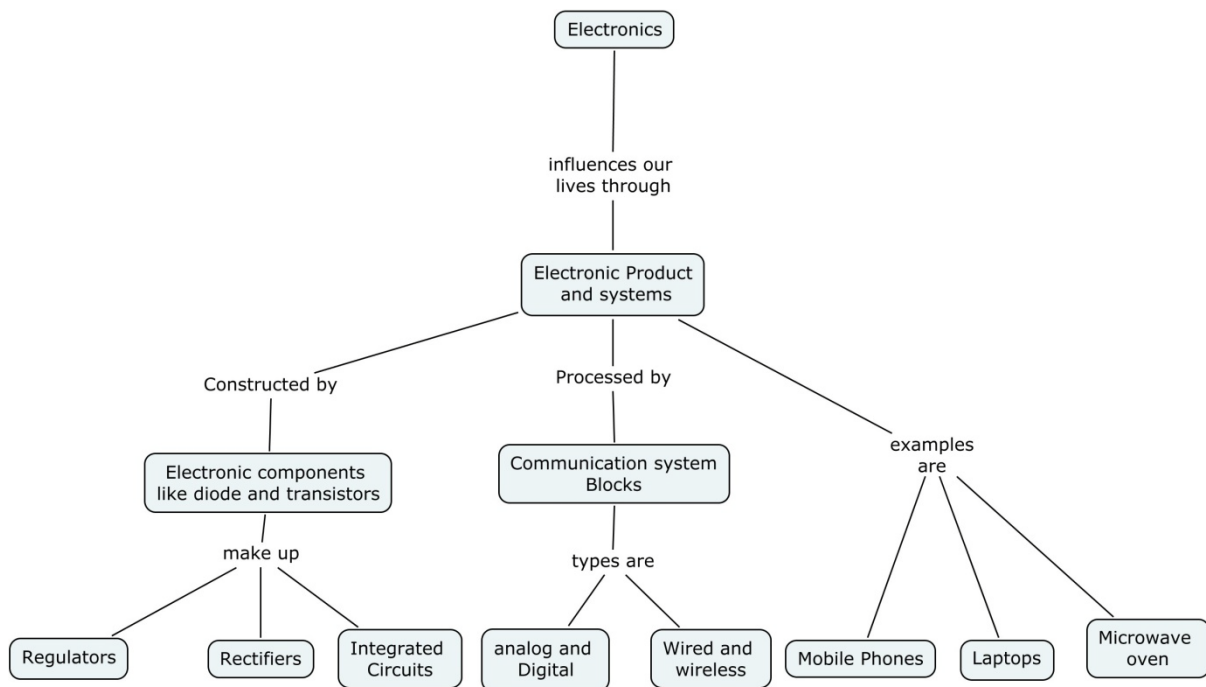

Syllabus

Electronics

Electrical Vs Electronics, Electronic products and systems, Electronic Devices (Diode – Forward bias, reverse bias, Transistor (CE, CB, CC)), Electronic components, Electronic Circuit (Rectifier, Regulator & IC), Amplifiers and Oscillators

Communication

Frequency spectrum and applications, Types of Communication systems (analog Vs digital, wire –optical, wireless, satellite), Communication system Block diagram (Transmitter and Receiver)

Applications

Mobile Phones, Laptop, Satellite, Microwave Oven – Qualitative Approach.

Text Book

1. Basic Electronics and Communication Engineering – Lecture Notes, Dept. of ECE, TCE, Madurai.

Reference Books

1. Albert Paul Malvino, "Electronic Principles", Tata Mcgraw Hill, 2002
2. Simon Haykin, "Communication Systems", Wiley Eastern, Third Edition, 1996
3. Faculty of Network Institutions, "Analog electronics", Project Network Engineering Series, 2004
4. Simon Haykin, Barry Van Veen, "Signals and Systems", Wiley, 2nd Edition, 2002

Course Contents and Lecture Schedule

Module No.	Topic	No. of Lectures
1.	Electronics	
1.1	Electrical and Electronics Principles	1
1.2	Electronic products and systems	1
1.3	Electronic Devices – Diodes and Transistors	1
1.4	Transistor Configuration CE, CB and CC	1
1.5	Electronic Circuits – Rectifier, Regulator & IC	1
1.6	Amplifiers and Oscillators	2
2.	Communication	
2.1	Frequency spectrum and applications	1
2.2	Types of Communication systems	1
2.3	Communication system Block diagram	1
2.4	Transmitter	1
2.5	Receiver	1
3.	Applications -Qualitative Approach.	
3.1	Mobile Phones	1
3.2	Laptops	1
3.3	Satellite	1
3.4	Microwave Oven	1
Total		16

Course Designers:

- | | |
|-----------------------------|--------------------|
| 1. Dr.S.Raju | hodece@tce.edu |
| 2. Dr.R.Sukanesh | drsukanesh@tce.edu |
| 3. Dr.M.Suganthi | msuganthi@tce.edu |
| 4. Dr.M.S.K.Manikandan | manimsk@tce.edu |
| 5. Dr.D.Gracia Nirmala Rani | gracia@tce.edu |

14ME170 ENGINEERING GRAPHICS

Category L T P Credit
ES 2 0 2 3

Preamble

Engineering Graphics is referred as language of engineers. An engineer needs to understand the physical geometry of any object through its orthographic or pictorial projections. The knowledge on engineering graphics is essential in proposing new product through drawings and interpreting data from existing drawings. This course deals with orthographic and pictorial projections, sectional views and development of surfaces.

Prerequisite

NIL

Course Outcomes

On successful completion of the course, students will be able to

- CO1: Draw the orthographic projections of points, straight lines, plane surfaces and solids. Apply
- CO2: Draw the orthographic projections of sectioned solids and true shape of the sections. Apply
- CO3: Develop lateral surfaces of the uncut and cut solids. Apply
- CO4: Draw the pictorial projections (isometric and perspective) of simple solids. Apply
- CO5: Sketch by free hand the orthographic views from the given pictorial view. Apply

Assessment Pattern

Bloom's Category	Continuous Assessment Tests			Terminal Examination
	1	2	3	
Remember				
Understand				
Apply	100	100	100	100
Analyse				
Evaluate				
Create				

Course Level Assessment Questions

Course Outcome 1: Students will be able to draw the orthographic projections of points, straight lines, plane surfaces and solids.

1. Draw the projection of points on a common reference line. Take 20 mm distance between the projectors.
 1. Point K is 10 mm above H.P. and 25 mm in front of V.P
 2. Point L is 10 mm above H.P. and on the V.P
 3. Point M is 25 mm below H.P. and 20 mm behind V.P
 4. Point N is 20 mm below H.P. and 20 mm in front of V.P
 5. Point O is on the reference line.
 6. Point P is on both H.P. and V.P

2. A line RS, 80 mm long has its end R, 20 mm above HP and 30 mm in front of VP. The top and front views of the line have the lengths of 50 mm and 65 mm respectively. Draw the projections of the line and find its true inclinations with HP and VP.
3. A thin rectangular plate of sides 60 mm x 30 mm has its shorter side in the V.P and inclined at 30° to the H.P. Project the top view of plate, if its front view is a square of 30 mm side.
4. Draw the projections of a pentagonal prism of base side 30 mm and axis length 60 mm when it lies on the ground on one of its rectangular faces with its axis inclined at 35° to V.P and parallel to H.P.

Course Outcome 2: Students will be able to draw the orthographic projections of sectioned solids and true shape of the sections.

1. A square pyramid of base 40 mm side and axis 65 mm long has its base on the ground and all the base edges equally inclined to V.P. It is cut by a section plane, perpendicular to V.P, inclined at 45° to H.P and bisecting the axis. Draw the elevation, sectional plan and true shape of the section.
2. A cube of 35 mm side is resting on ground on one of its faces with a vertical face inclined at 30° to VP. It is cut by a cutting plane perpendicular to HP and inclined at 60° to VP so that a face which makes 60° angle with VP is cut into two equal halves. Draw the sectional elevation, plan and true shape of the section.
3. A cone of 60 mm base circle diameter and axis height 70 mm is resting on HP with a point on its circumference such that the generator containing that point is perpendicular to HP. The cone is cut by a plane parallel to HP and perpendicular to VP bisecting the axis. Draw the elevation and sectional plan.

Course Outcome 3: Students will be able to develop lateral surfaces of the uncut and cut solids.

1. A pentagonal pyramid of base 50 mm side and axis 75 mm long has its base on the ground. It is cut by a section plane, perpendicular to V.P, inclined at 30° to H.P intersecting the axis at 40 mm from apex. Draw the development of the lateral surface of its lower portion.
2. A hexagonal prism of 45 mm side and axis height 70 mm is resting on ground with its base. It is cut by i) a horizontal cutting plane at 25 mm from base and ii) a cutting plane inclined to HP at 35° passing through a point on the axis at 20 mm from its top. Draw the development of the lateral surface of its middle portion.
3. A cylinder of 70 mm base diameter and axis height 90 mm is resting on HP with its base. It contains a circular through hole of 30 mm diameter on its periphery, with the axis of hole parallel to HP and perpendicular to VP, bisecting the cylinder axis. Draw the development of the cylindrical surface.

Course Outcome 4: Students will be able to draw the pictorial projections (isometric and perspective) of simple solids.

1. Draw the isometric view of a pentagonal pyramid of base side 32 mm and height 75 mm when its base is parallel to HP with one of its base edges parallel to VP. The vertex is below the base.
2. Draw the isometric projection of a hexagonal prism of base side 30 mm and height 70 mm when it lies on the ground with one of its face edges and axis parallel to HP and VP.
3. A regular hexagonal pyramid of base edge 30 mm and height 50 mm rests on its base on the ground plane with one of its base edges touching the picture plane. The station point is 40 mm above the ground plane and 50 mm in front of PP. The central plane is 35 mm to the right of the axis. Draw the perspective projection of the pyramid. A cylinder of diameter 40 mm and height 50 mm rests on GP on one of its ends with its axis 40 mm behind the picture plane. The station point is 50 mm to the

right of the axis. The station point is 70 mm above the GP and 45 mm in front of PP. Draw the perspective view of the cylinder.

Course Outcome 5: Students will be able to sketch by free hand the orthographic views from the given pictorial view.

1. Draw the front view, top view and left side views of the given block from its pictorial view.

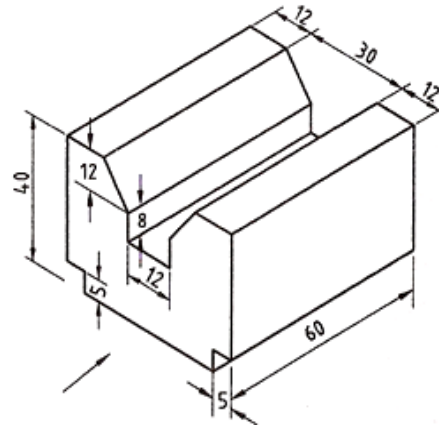

2. Draw the orthographic projections for the given object.

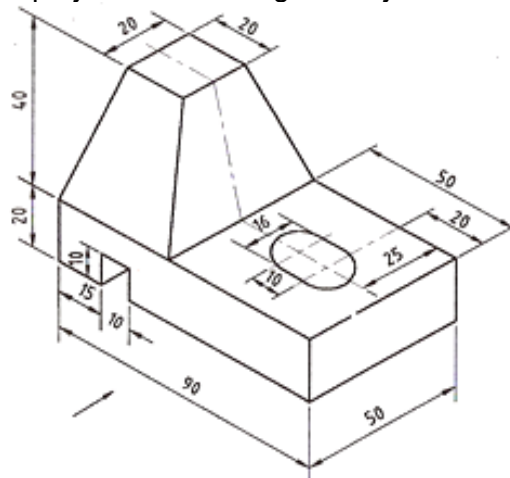

3. Draw the Elevation, Plan and Right side view for the given shaft bracket.

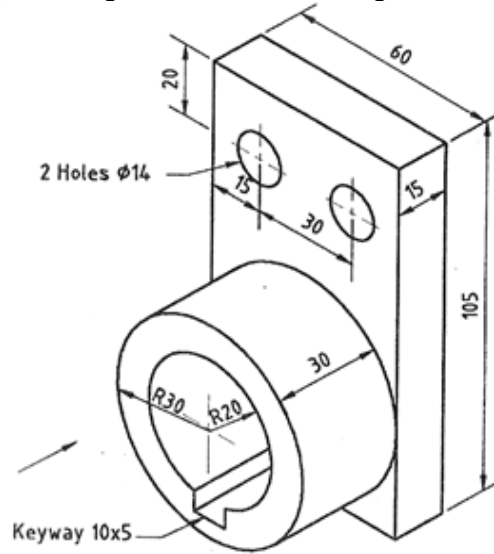

Concept Map

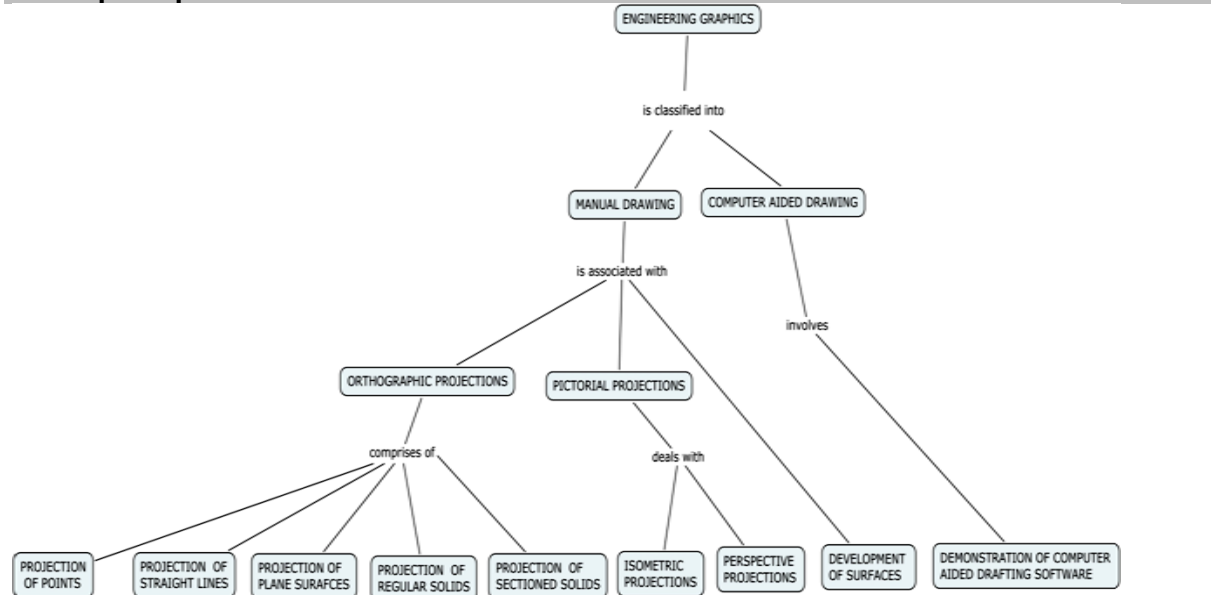

Syllabus

Introduction- Importance of graphics in engineering applications – Use of drafting instruments -Size, layout and folding of drawing sheets - BIS Standards – Lettering and dimensioning, construction of polygons.

Orthographic projections - Introduction - Principles -Principal planes-First angle projection.

Projection of points located in all quadrants. **Projection of straight lines** inclined to both the principal planes - Determination of true lengths and true inclinations by rotating line method, traces. **Projection of planes** (regular polygonal and circular surfaces) inclined to both the principal planes by rotating object method. **Projection of regular solids*** by rotating object method when the axis is inclined to one of the principal planes. **Projection of sectioned solids** and true shape of the sections (Axis of the solid perpendicular to HP).

Development of lateral surfaces of regular* and sectioned solids.

Pictorial Projections – Introduction - **Isometric projection** – Principle, isometric scale, Isometric projections of regular solids* when the axis is i) perpendicular to HP ii) perpendicular to VP (iii) parallel to both HP and VP. **Perspective projection** - Principle, perspective projection of regular solids* when the axis is perpendicular to i) Ground Plane ii) Picture plane by visual ray method.

Free hand sketching of multiple orthographic views from single pictorial view of objects.
Introduction to drafting packages and demonstration. (Not for examination).
 (*prisms, pyramids, cylinder and cone).

Text Book

1. Bhatt N.D. and Panchal V.M., "Engineering Drawing", Charotar Publishing House, 50th Edition, 2010.

Reference Books

1. Natarajan K.V., "A text book of Engineering Graphics", Dhanalakshmi Publishers, Chennai, 2009.
2. Basant Agarwal and Agarwal C.M., "Engineering Drawing", Tata McGraw Hill Publishing Company Limited, New Delhi, 2008
3. Venugopal K. and Prabhu Raja V., "Engineering Graphics", New Age International (P) Limited, 2008.
4. Gopalakrishna K.R., "Engineering Drawing" (Vol. I&II combined), Subhas Stores, Bangalore, 2007.

Course Contents and Lecture Schedule

Sl.No	Topic	Lecture Hrs (Periods)	Practical Hrs (Periods)
1	Introduction- Importance of graphics in engineering applications – Use of drafting instruments -Size, layout and folding of drawing sheets – BIS Standards - Lettering and dimensioning, construction of polygons.	2	3
2	Orthographic projection - Introduction - Principles -Principal planes-First angle projection, Projection of points located in all quadrants.	2	3
3	Projection of straight lines inclined to both the principal planes - Determination of true lengths and true inclinations by rotating line method, traces.	4	6
4	Projection of planes (regular polygonal and circular surfaces) inclined to both the principal planes by rotating object method.	4	6
5	Projection of regular solids (prisms, pyramids, cylinder and cone) when the axis is inclined to one of the principal planes by rotating object method.	4	6
6	Projection of sectioned solids and true shape of the sections (Axis of the solid perpendicular to HP)	2	3
7	Development of lateral surface of regular and truncated solids.	2	3
8	Isometric projection – Principle, isometric scale, Isometric projections of regular solids when the axis is i) perpendicular to HP ii) perpendicular to VP (iii) parallel to both HP and VP.	2	3
9	Perspective projection - Principle, perspective projection of regular solids when the axis is perpendicular to i)Ground Plane ii) Picture plane by visual ray method.	2	3
10	Free hand sketching of multiple orthographic views from pictorial view of objects.	2	3
11	Introduction to drafting packages and demonstration.	2	-
	Test		3
	TOTAL	28	42

Question Pattern for Terminal Examination			
Question Number	Description	Type	Marks
1	Projection of Points (OR) Free hand sketching of orthographic views from pictorial views	Either or	10
2	Projection of lines	Either or	15
3	Projection of planes	Either or	15
4	Projection of solids	Either or	15
5	Section of solids	Either or	15
6	Development of surfaces	Either or	15
7	Isometric Projection (OR) Perspective projection	Either or	15
Total			100

- Note:**
- Plates (Drawing sheets) submitted by students will be considered for internal assignment marks (30).
 - One test will be conducted locally by respective faculty-in-charge during regular class hours for internal test marks (20).
 - Terminal examination will be conducted centrally by the office of controller of examinations.

Course Designers:

- | | | |
|----|------------------|--------------------|
| 1. | Mr.A.Samuel Raja | samuel1973@tce.edu |
| 2. | Mr.M.Kannan | mknmech@tce.edu |

14PH180	PHYSICS LABAROTARY	Category	L	T	P	Credit
		BS	0	0	2	1

Preamble

The course aims in imparting fundamental knowledge of experimental Physics. The error analysis is essential for understanding and analyzing the results of any experiment. Basic experiments in thermal applications and optics are introduced. Characteristics and uses of Laser & fiber optics have been included. The outcome of the course is to help students determine physical constants, Viscosity, Band gap, wavelength of a Laser and Acceptance angle of a fiber.

LIST OF EXPERIMENTS

1. Error analysis
2. Compound pendulum- acceleration due to gravity
3. Poiseulle's flow method-viscosity determination
4. Solar cell characteristics
5. Plank's constant determination
6. Energy band gap of junction diode
7. Spectrometer – dispersive power of the prism
8. Microscope- thickness of wire by air wedge
9. Laser- particle size and wavelength determination
10. Fiber optics –numerical aperture & acceptance angle determination

Course Designers:

- | | |
|---------------------|----------------|
| 1. Dr.R.Vasuki | rvphy@tce.edu |
| 2. A.L.Subramaniyan | alsphy@tce.edu |
| 3. D.Ravindran | drphy@tce.edu |

		Category	L	T	P	Credit
14CH190	CHEMISTRY LABORATORY	BS	0	0	2	1

Preamble

The objective of this course is to develop the intellectual and psychomotor skills of the students by imparting knowledge in material, quantitative and electrochemical analysis.

Course Outcomes

On the successful completion of the course, students will be able to

- | | |
|--|---------|
| • Analyse the material qualitatively | Analyse |
| • Estimate the chemical parameters of water | Apply |
| • Calculate the strength of acids, oxidizing and reducing agents | Analyse |

List of Experiments

1. Material analysis

- i) Analysis of Boiler scale
- ii) Analysis of Cement
- iii) Analysis of alloy sample

2. Quantitative analysis

- i) Estimation of Total Hardness of water sample
- ii) Estimation of Ca^{2+} and Mg^{2+} individual hardness of water sample
- iii) Estimation of Alkalinity of water sample
- iv) Estimation of Chloride in a water sample
- v) Estimation of COD

3. Electrochemical analysis

- i) Conductometry Titration (Strong acid Vs Strong base, Mixture of acids Vs Strong base)
- ii) Potentiometric redox Titration ($\text{K}_2\text{Cr}_2\text{O}_7$ Vs FAS, KMnO_4 Vs FAS)

Course Designers:

- | | | |
|----|-----------------|--------------------|
| 1. | Dr.K.Radha | hodchem@tce.edu |
| 2. | Dr.S.Balaji | sbalaji@tce.edu |
| 3. | Dr.V.Velkannan | velkannan@tce.edu |
| 4. | Dr.S.Sivailango | drssilango@tce.edu |

CURRICULUM AND DETAILED SYLLABI

FOR

B.E. DEGREE (Mechatronics) PROGRAMME

SECOND to EIGHTH SEMESTERS

**FOR THE STUDENTS ADMITTED FROM THE
ACADEMIC YEAR 2014-2015 ONWARDS**



THIAGARAJAR COLLEGE OF ENGINEERING

(A Govt. Aided Autonomous Institution affiliated to Anna University)

MADURAI – 625 015, TAMILNADU

Phone: 0452 – 2482240, 41

Fax: 0452 2483427

Web: www.tce.edu

Preamble

Vector calculus focuses on differentiation and integration of vector fields, primarily in 3-dimensional Euclidean space \mathbb{R}^3 . Vector calculus plays an important role in differential geometry and in the study of partial differential equations. It is used extensively in electromagnetic fields, gravitational fields and fluid flow.

A complex function is one in which the independent variable and the dependent variable are both complex numbers. More precisely, a complex function is a function whose domain and range are subsets of the complex plane. Complex analysis is widely applicable to hydrodynamics, thermodynamics, nuclear, aerospace, mechanical and electrical engineering. Another important application of complex analysis is in string theory which studies conformal invariants in quantum field theory.

The Laplace transform is a widely used integral transform in mathematics with many applications in physics and engineering. Laplace transformation is a linear operator of a function $f(t)$ with a real argument t ($t \geq 0$) that transforms $f(t)$ to a function $F(s)$ with complex argument s .

Laplace transformation from the time domain to the frequency domain transforms differential equations into algebraic equations and convolution into multiplication. A mathematical description of the input-output relation of a system can be formulated either in the time domain or in the frequency domain. Laplace transform is often interpreted as a transformation from the time-domain, in which inputs and outputs are functions of time, to the frequency-domain, where the same inputs and outputs are functions of complex angular frequency, in radians per unit time.

Laplace transform is used for solving differential and integral equations. In physics and engineering it is used for analysis of linear time-invariant systems such as electrical circuits, harmonic oscillators, optical devices, and mechanical systems. Laplace transform is a very effective mathematical tool to simplify very complex problems in the area of stability and control.

The z-transform is the discrete-time counter-part of the Laplace transform.

A discrete system is expressible as a difference equation and its solution are found using Z-transforms.

The Laplace transform and its discrete-time counterpart z-transform are essential mathematical tools for system design and analysis, and for monitoring the stability of a system. A working knowledge of the z-transform is essential to the study of discrete-time filters and systems. It is through the use of these transforms that we formulate a closed-form mathematical description of a system in the frequency domain, design the system, and then analyze the stability, the transient response and the steady state characteristics of the system.

Prerequisite

Elementary differential calculus and integral calculus.

Course Outcomes

On the successful completion of the course, students will be able to

CO 1.	Solve linear and constant coefficient difference equations using Z-transforms	Apply
CO 2.	Apply the vector differential operators to represent the physical phenomena like gradient, directional derivative, curl, divergence and to verify vectors for irrotational and solenoidal.	Apply
CO 3.	Find work done by line integral of vector point function and inferring the relations among line integral, surface integral and volume integral using Green's, Stoke's and Gauss Divergence theorems.	Apply
CO 4	Apply Laplace transform to solve the given ordinary differential equation and system of ODE	Apply
CO 5.	Construct an analytic function, when its real or imaginary part is known and discuss about the transformations of standard functions such as $\sin z$, z^2 , e^z and identify the singular points of a given complex function	Apply

Mapping with Programme Outcomes

COs	PO1	PO2	PO3	PO4	PO5	PO6	PO7	PO8	PO9	PO10	PO11	PO12
CO1.	S	S	S	S	L	L	L	L	M	M	L	S
CO2.	S	S	M	M	L	L	L	L	M	M	L	S
CO3.	S	S	M	M	L	L	L	L	M	M	L	S
CO4.	S	S	S	S	L	L	L	L	M	M	L	S
CO5.	S	S	M	M	L	L	L	L	M	M	L	S

S- Strong; M-Medium; L-Low

Assessment Pattern

Bloom's Category	Continuous Assessment Tests			Terminal Examination
	1	2	3	
Remember	10	10	10	10
Understand	20	20	20	20
Apply	70	70	70	70
Analyse	-	-	-	-
Evaluate	-	-	-	-
Create	-	-	-	-

Course Level Assessment Questions

Course Outcome 1 (CO1):

1. Compute $Z[a^n \sin nq]$ and $Z[a^n \cos nq]$
2. State and prove final value theorem
3. Use convolution theorem to evaluate $Z^{-1}\left[\frac{z^2}{(z-a)(z-b)}\right]$
4. Using Z-transform, solve $u_{n+2} + 4u_{n+1} + 3u_n = 3^n$ with $u_0 = 0$ and $u_1 = 1$.

Course Outcome 2 (CO2):

1. Prove that $\text{curl } \vec{r} = 0$
2. Find the angle between the surfaces $x^2 + y^2 + z^2 = 9$ and $z = x^2 + y^2 - 3$.
3. Find a unit vector normal to the surface $x^3 + y^3 + 3xyz = 3$ at the point (1,2,-1).
4. Check whether the following vector is solenoidal or not $\nabla\Phi \times \nabla\Psi$.

Course Outcome 3 (CO3):

1. Verify Greens theorem for $\int_C [(xy + y^2)dx + x^2dy]$, where C is bounded by $y = x$ and $y = x^2$.
2. If S be the surface of the sphere $x^2 + y^2 + z^2 = 1$, prove that $\int_S \text{curl } \vec{F} \cdot ds = 0$.
3. Show that $\int_C R \cdot dR = 0 = 0$ independently of the origin of R .
4. Find the work done in moving the particle in the force $3x^2i + (2xz - y)j + zk$ along a straight line joining the origin to (2,1,3).

Course Outcome 4 (CO4):

1. Solve the Equation $y'' + 9y = \cos 2t, y(0) = 1$ & $y\left(\frac{\pi}{2}\right) = -1$ using Laplace Transform.
2. Compute $L^{-1}\left(\frac{p+8}{p^2+4p+5}\right)$
3. Using convolution theorem in Laplace Transform, evaluate $\int_0^t \text{SinuCos}(t-u)du$

4. Show that $\int_0^t e^{-4t} t \sin 3t dt = \frac{6}{(s^2 + 8s + 25)^2}$.

Course Outcome 5 (CO5)

1. Compute an analytic function $f(z)=u+iv$, where $u = e^x(x \cos y - y \sin y)$.
2. Show that the map $w = 1/z$ maps the circles and straight lines as circles or straight lines.

3. Identify the singular points of $\frac{1}{(2 \sin z - 1)^2}$

4. Distinguish between isolated singularity and removable singularity

Concept Map

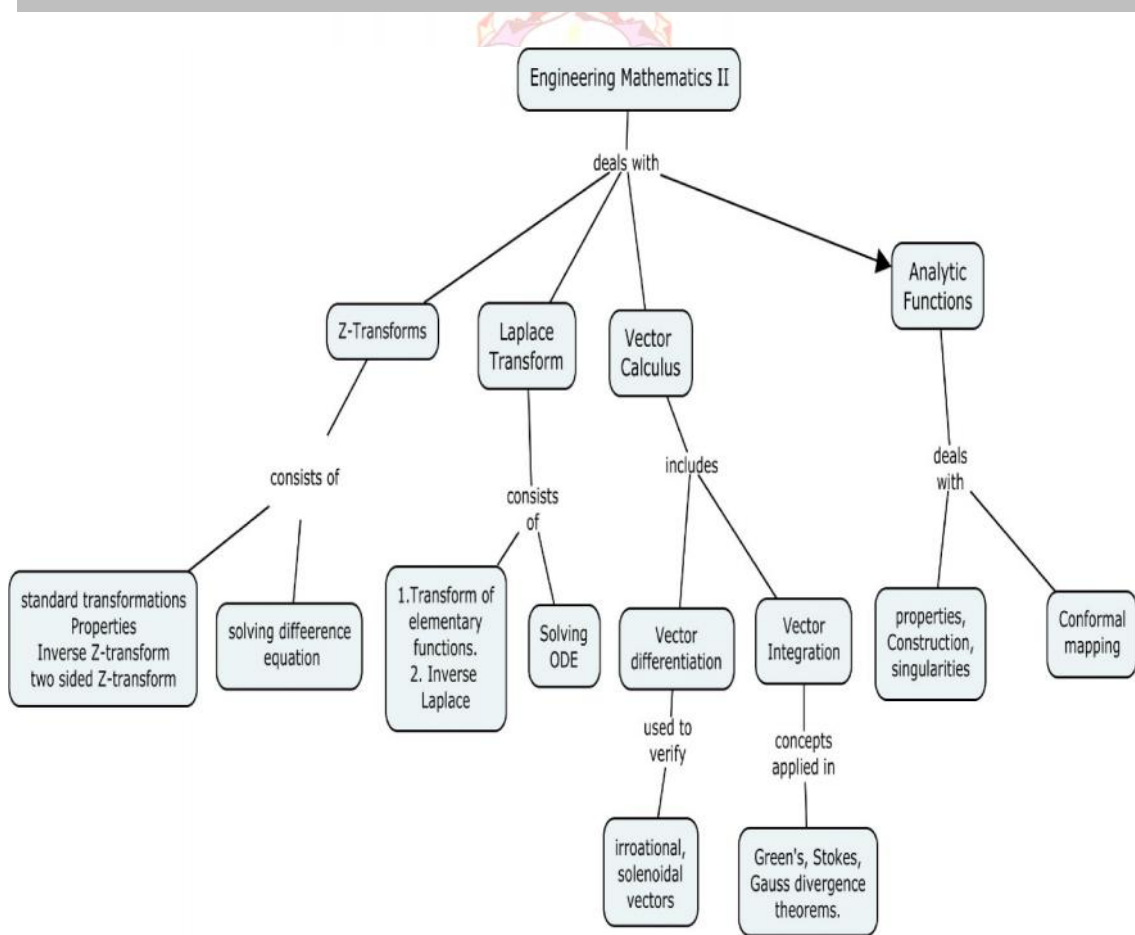

Syllabus:

VECTOR CALCULUS: Gradient, divergence and curl – Directional derivative – Irrotational and solenoidal vectors – Simple problems on Vector differentiation – Vector integration - Line , Surface and Volume Integrals – Green’s theorem in a plane, Gauss divergence theorem and Stokes’ theorem(excluding proofs) – Simple problems using the above three theorems.

ANALYTIC FUNCTIONS: Functions of complex variables – Analytic functions: Necessary conditions – Cauchy - Riemann equations and sufficient conditions (excluding proofs) – Properties of analytic functions – Harmonic and conjugate functions – Construction of an analytic function – Singularity-Conformal mapping: $w = z^2$, $\sin z$, e^z and bilinear transformation.

LAPLACE TRANSFORM: Laplace transform –Sufficient condition for existence – Transform of elementary functions – Basic properties – Transforms of derivatives and integrals of functions -Derivatives and integrals of transforms - Transforms of unit step function and impulse functions – Transform of periodic functions. Inverse Laplace transform -Statement of Convolution theorem and simple problems – Initial and final value theorems–Solution of linear ODE of second order with constant coefficients and system of ordinary differential equations using Laplace transformation

Z-TRANSFORMS: Standard Z - transforms – properties of Z - transform – Convolution theorem – Convergence – Two sided Z-transform - Inverse Z-transform – Solving difference equations using Z-transforms.

Text Book

1. Grewal. B.S, “**Higher Engineering Mathematics**”, 41st Edition, Khanna Publications, Delhi, 20112.
2. Erwin Kreyszig, “**Advanced Engineering Mathematics**”, 8th Edition, John Wiley & Sons, 2009.

Reference Books

1. T. Veerarajan, “**Engineering Mathematics**”, 3rd Edition, Tata McGraw Hill, New Delhi, 2004.
2. Thomas Phinny, “**Calculus**”, 13th Edition, Pearson Education, New Delhi, 2005.
3. B.V.Ramana, “**Higher Engineering Mathematics**”, Tata Macraw Hill, New Delhi,2011

Course Contents and Lecture Schedule

Module No.	Topic	No.of Lectures
1	Vector Calculus:	
1.1	Vector differential Operator: Grad, Div , Curl, Solenoidal and Irrotational Vectors	1
	Tutorial	2
1.2	Line , Surface and Volume Integrals	1
1.3	Simple Problems on Line, Surface and Volume Integrals	1
1.4	Green's, Stoke's and Gauss Divergence theorem(without Proof) Simple Problems using Green's, Stoke's and Gauss Divergence theorem	2
	Tutorial	3
2	Analytic Functions	
2.1	Analytic functions, C-R equations and properties	1
2.2	Harmonic functions and Milne Thomson's method	1
	Tutorial	2
2.3	Singularities	1
	Tutorial	1
2.4	Conformal maps and bilinear transformations	2
	Tutorial	2
3	Laplace Transformation	
3.1	Laplace transformations of some standard functions-properties,	1
3.2	Problems using properties	1
	Tutorial	2
3.3	Inverse Laplace transformation	1
	Tutorials	1
3.4	Periodic functions, convolution theorem, initial value theorem and final value theorem	1
3.5	Solution of differential equations and integral equations	1
	Tutorial	2
4	Z-Transforms	
4.1	Standard Z transforms, properties of Z transform	1
	Tutorial	2
4.2	Convolution theorem, Two sided Z transform	1
	Tutorial	1
4.5	Inverse Z transform	1
4.6	Applications to Z transform	2
	Tutorial	2
	Total	40

Course Designers:

- | | | |
|----|---------------------|----------------------|
| 1. | M. Kameshwari | mkmat@tce.edu |
| 2. | C. S. Senthil kumar | kumarstays@tce.edu |
| 3. | R. Suresh | suresh080183@tce.edu |

14MT220	FREE BODY MECHANICS	Category	L	T	P	Credit
		PC	2	1	0	3

(Common with 14ME220 – Free Body Mechanics)

Preamble

Mechanics is the branch of physics concerned with the behavior of physical bodies when subjected to forces or displacements, and the subsequent effect of the bodies on their environment. The discipline has its roots in several ancient civilizations. Scientists such as Galileo, Kepler and especially Newton, during the early modern period, laid the foundation for what is now known as classical mechanics. The often-used term ‘body’ in the field of mechanics stands for a wide assortment of objects, including particles, projectiles, spacecraft, stars, parts of machinery, parts of solid, parts of fluids (gases and liquids) etc. Distinctions between the various sub-disciplines of mechanics, concern the nature of the bodies being described. Sub-disciplines of mechanics include Newtonian mechanics (dynamics, theory of motion and forces), Lagrangian mechanics (a theoretical formalism based on the principle of conservation of energy), Hamiltonian mechanics (another theoretical formalism based on the principle of the least action), Celestial mechanics (the motion of heavenly bodies: planets, comets, stars, galaxies, etc.), Astrodynamics (spacecraft navigation etc.), Solid mechanics (properties of rigid bodies), Elasticity (properties of semi-rigid bodies), Acoustics (density variation propagation in solids, fluids and gases), Statics (semi-rigid bodies in (mechanical equilibrium), Fluid mechanics (the motion of fluids), Soil mechanics (mechanical behavior of soils), Continuum mechanics (mechanics of continua - both solid and fluid), Hydraulics (mechanical properties of liquids), Fluid statics (liquids in equilibrium)

Prerequisite

- 14MA110 : Engineering Mathematics-I
- 14PH120 : Physics

Course Outcomes

On the successful completion of the course, students will be able to

- | | | |
|--------------|--|----------|
| CO 1. | Enumerate the basic of concept of mechanics and fundamentals of friction | Remember |
| CO 2. | Solve problems in engineering systems using the concept of static equilibrium | Apply |
| CO 3. | Determine the centroid of a line, areas, and volumes, center of mass of body and moment of inertia of composite areas. | Apply |
| CO 4. | Solve problems involving frictional phenomena in machines | Apply |
| CO 5. | Solve problems involving kinematics and kinetics of particles in two- and three-dimensions | Apply |
| CO 6. | Solve problems involving kinematics and kinetics of rigid bodies in plane motion. | Apply |
| CO 7. | Solve problems using D’Alembert principles. | Apply |

Mapping with Programme Outcomes

COs	PO1	PO2	PO3	PO4	PO5	PO6	PO7	PO8	PO9	PO10	PO11	PO12
CO1.	L	-	-	-	-	-	-	-	-	-	M	-
CO2.	S	M	M	-	-	-	-	-	-	-	M	-
CO3.	S	M	M	-	-	-	-	-	-	-	M	-
CO4.	S	M	M	-	-	-	-	-	-	-	M	-
CO5.	S	M	M	-	-	-	-	-	-	-	M	-
CO6.	S	M	M	-	-	-	-	-	-	-	M	-
CO7.	S	M	M	-	-	-	-	-	-	-	M	-

Assessment Pattern

Bloom's Category	Continuous Assessment Tests			Terminal Examination
	1	2	3	
Remember	20	20	20	20
Understand	20	20	20	20
Apply	60	60	60	60
Analyse	-	-	-	-
Evaluate	-	-	-	-
Create	-	-	-	-

Course Level Assessment Questions

Course Outcome 1 (CO1):

1. Define equilibrium of mechanical system.
2. State law of friction.
3. Describe the dynamic equilibrium of a rigid body in plane motion.
4. State the Newton's law of motion.

Course Outcome 2 (CO2):

1. Determine the resultant of two force P and Q act on a bolt A

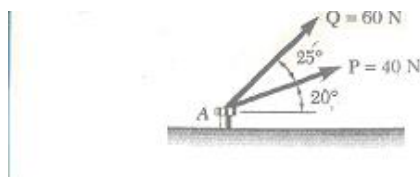

2. A barge is pulled by two tugboats. If the resultant of the forces exerted by the tugboats is a 5000 N force directed along the axis of the barge, determine the a) the tension in

each of the ropes knowing that $\alpha = 45^\circ$ b) the value of α for which the tension in rope 2 is minimum.

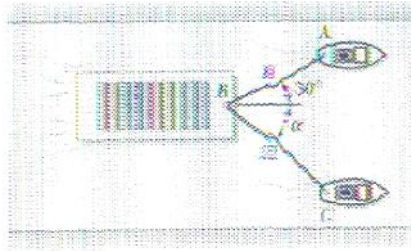

3. Four forces act on bolt A shown, Determine the resultant of the forces on the bolt,

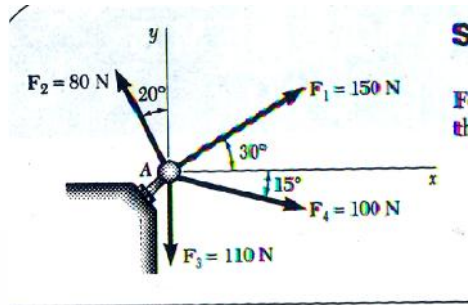

4. Determine the reactions at A for the beam subjected to the following load distribution (figure 1)

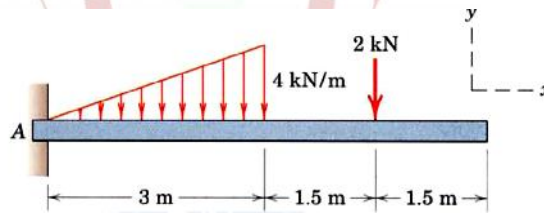

Course Outcome 3 (CO3):

1. Define centroid of an area
2. State parallel axis theorem
3. State perpendicular axis theorem.
4. Determine the moment of inertia of the shaded are with respect to the x axis

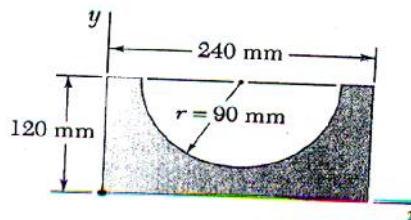

5. Determine the moment of inertia and radius of gyration of the shaded area with respect to the x axis

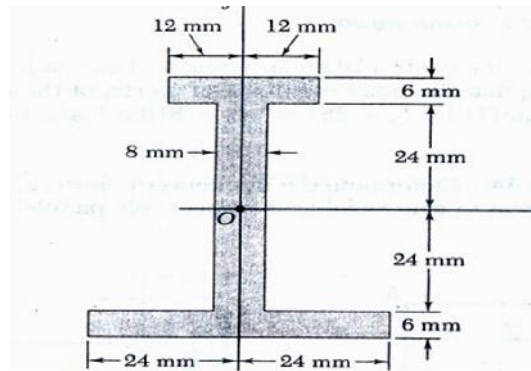

6. Locate the centre of gravity of the given shape as shown in figure

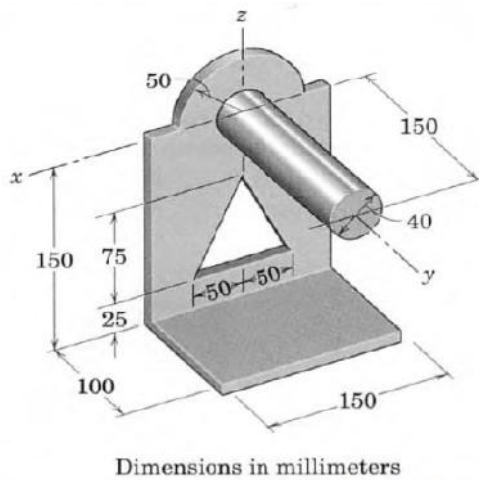

Course Outcome 4 (CO4):

1. A body of mass 4 kg lying on a rough horizontal plane is attached to one end of a string. The string passes over a smooth pulley and carries at its other end, a body of mass 10 kg which hangs freely vertically down. If the system starts from rest and attains an acceleration of 6 m/s^2 , find the coefficient of friction.
2. Determine the horizontal force P required to raise the 200kg block. The coefficient of friction for all surfaces is 0.40.
3. If the coefficient of friction between the steel wedge and the moist fibers of the newly cut stump is 0.20, determine the maximum angle which the wedge may have and not pop out of the wood after being driven by the sledge.

Course Outcome 5 (CO5):

1. Steep safety ramps are built beside mountain highways to enable vehicles with defective brakes to stop safely. A truck enters a 250m ramp at a high speed V_0 and travels 180m in 6s at constant deceleration before its speed is reduced to $V_0/2$. Assuming the same constant deceleration, determine a) the additional time required for the truck to stop b) the additional distance travelled by the truck.
2. A flywheel rotates about its centre, and has a mass of 50kg. It rotates freely at a constant angular velocity of 100rpm when a brake is applied as shown in fig.. Find the angular acceleration of the flywheel, and determine the time taken T for it to come to rest.
3. A 0.5 kg baseball is pitched with a velocity of 80 m/s. After the ball is hit by the bat, it has a velocity of 120 m/s in the direction shown. If the bat and ball are in contact for 0.015 s, determine the average impulsive force exerted on the ball during the impact.

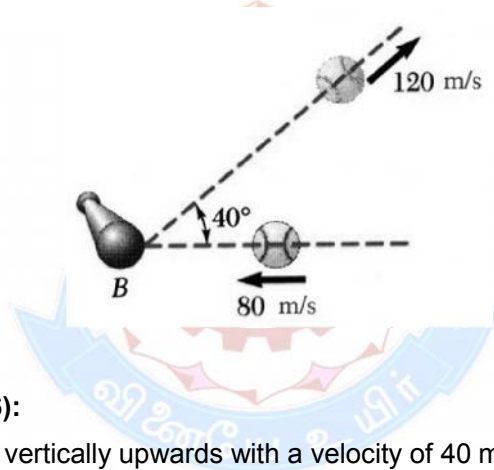

Course Outcome 6 (CO6):

1. A Stone is thrown vertically upwards with a velocity of 40 m/sec. Find its position after 5 seconds.
2. A body of mass 4 kg lying on a rough horizontal plane is attached to one end of a string. The string passes over a smooth pulley and carries at its other end, a body of mass 10 kg which hangs freely vertically down. If the system starts from rest and attains an acceleration of 6 m/s^2 , find the coefficient of friction.
3. A pulley weighing 12 N and having a radius of gyration of 8 cm is connected to two blocks as shown. Assuming no axle friction, determine the angular acceleration of the pulley and the acceleration of each block.

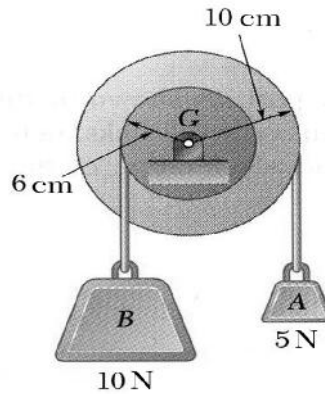

Course Outcome 7 (CO7):

1. A flywheel executes 1800 revolutions while it coasts to rest from speed of 6000 rpm. Assuming uniformly accelerated motion, determine (a) the time required for the flywheel to coast to rest, (b) the time required for the flywheel to execute the first 900 revolutions.
2. Two identical 1350-kg automobiles A and B are at rest with their brakes released when B is struck by a 5400-kg truck C which is moving to the left at 8 km/h. A second collision then occurs when B strikes A. Assuming the first collision is perfectly plastic and the second collision is perfectly elastic, determine the velocities of the three vehicles just after the second collision.



3. For the drum and flywheel, $I = 10.5 \text{ kg}\cdot\text{m}^2$. The bearing friction is equivalent to a couple of 60 Nm . At the instant shown, the block is moving downward at 6 m/s . Determine the velocity of the block after it has moved 4 m downward.

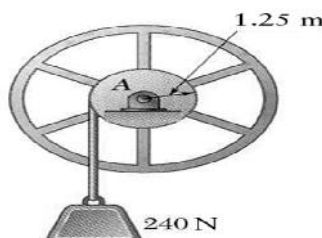

Concept Map

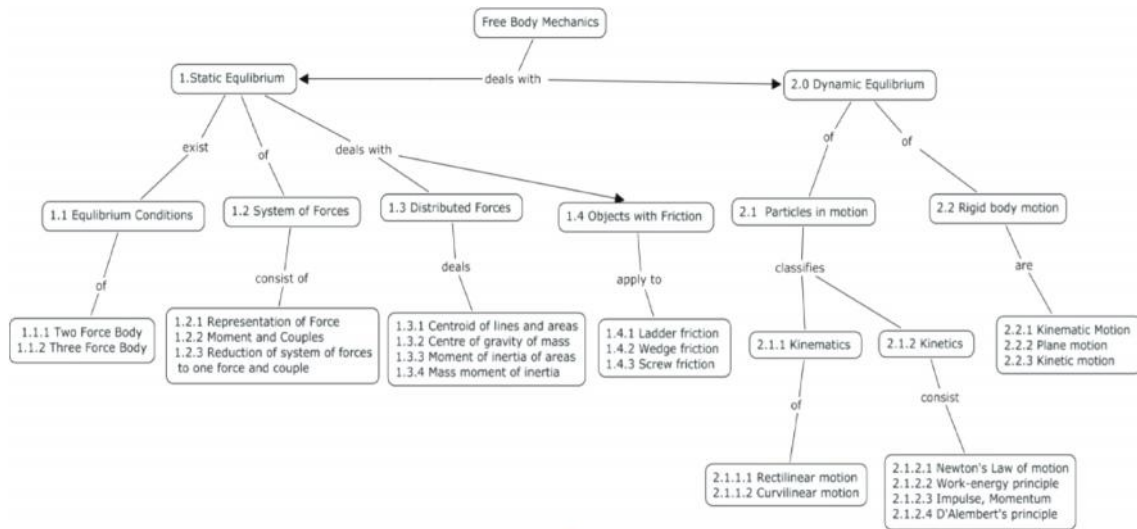

Syllabus

Static Equilibrium of Mechanical Systems: Equilibrium conditions-Two force body-Three force body.

System of forces: Representation of Force, Moment and Couples-Reduction of system of forces to one force and couple. **Distributed forces:** Centroid of lines and areas-Centre of gravity of mass-Moment of inertia of areas-Mass moment of inertia.

Objects with friction: Ladder friction-Wedge friction-Screw friction-Applications

Dynamic equilibrium: Particles in motion-Kinematics of particles-Rectilinear motion-Curvilinear motion-Kinetics of particles-Newton's Law of motion-Work-energy principle-Impulse-Momentum principle, D'Alembert's principle.

Rigid body motion: Kinematic Motion -Rotary motion of rigid bodies-Plane motion-Kinetic motion.

Text Books

1. Beer F.P. and Johnston Jr. E.R., **Vector Mechanics for Engineers: Statics and Dynamics**, Eighth Edition, Tata McGraw Hill, 2008.
2. Meriam J.L and Kraig L.G, 'Engineering., **Mechanics-Statics and Dynamics**, John Wiley & sons, Newyork, 2008.

Reference Books

1. Boresi A.P. and Schmidt R.J., **Engineering Mechanics and Dynamics**, Thomson Asia Press, Singapore, 2004.

2. Shames. I.H, Engineering Mechanics – Statics and Dynamics, Pearson Education, Asia, 2006.
3. Palanichamy and Nagan S., **Engineering Mechanics – Statics and Dynamics**, Tata McGraw Hill, 2005.
4. Lakshmana Rao: **Engineering Mechanics– Statics and Dynamics**, Prentice Hall of India, New Delhi, 2003.
5. Timoshenko, S, Young, D, Rao. J, **Engineering Mechanics**, Fourth Edition, Tata McGraw Hill, 2006.

Course Contents and Lecture Schedule

Module No.	Topic	No. of Lectures
1	Static Equilibrium of Mechanical Systems	
1.1	Equilibrium conditions	1
1.1.1	Two force body	
1.1.2	Three force body	1
1.2	System of forces	
1.2.1	Representation of Force,	2
1.2.2	Moment and Couples	2
1.2.3	Reduction of system of forces to one force and couple	1
1.3	Distributed forces	
1.3.1	Centroid of lines and areas	2
1.3.2	Centre of gravity of mass	2
1.3.3	Moment of inertia of areas	2
	Tutorial Problems in Moment of Inertia	2
1.3.4	Mass moment of inertia	2
	Tutorial Problems in Mass Moment of Inertia	2
1.4	Objects with friction	
1.4.1	Ladder friction	2
1.4.2	Wedge friction	2
1.4.3	Screw friction	2
	Tutorial Problems in Friction	2
2	Dynamic equilibrium	

2.1	Particles in motion	
2.1.1	Kinematics of particles	1
2.1.1.1	Rectilinear motion	1
2.1.1.2	Curvilinear motion	1
2.1.2	Kinetics of particles	1
2.1.2.1	Newton's Law of motion	2
2.1.2.2	Work-energy principle	2
2.1.2.3	Impulse, Momentum	2
	Tutorial Problems	2
2.1.2.4	D'Alembert's principle	1
2.2	Rigid body motion	
2.2.1	Kinematic Motion –Rotary motion of Rigid bodies	1
2.2.2	Plane motion	2
2.2.3	Kinetic motion	2
	Tutorial Problems	2
	Total	48

Course Designers:

1. G.Kanagaraj gkmech@tce.edu
2. V.Balasubramani vbmech@tce.edu

Preamble

In future, the machines play a vital role in transforming the manufacturing system into automatic system. An electrical machine is the apparatus that converts energy in three categories: generators which convert mechanical energy to electrical energy, motors which convert electrical energy to mechanical energy, and transformers which changes the voltage level of an alternating current. The academic study of electric machines has become considerable importance in recent years for development of mechatronics in industries. This course aims to provide knowledge on construction and working principle, advantages, limitations and applications of various industrial machines.

Prerequisite

- 14MA110 : Engineering Mathematics-I
- 14PH120 : Physics
- 14ES160 : Basic electrical and electronics engineering

Course Outcomes

CO 1.	Explain the various types of Machines, principle and operation.	Understand
CO 2.	Explain the Construction principle and control of different types of Machines.	Understand
CO 3.	Explain the characteristics, Application of different types of Machines.	Understand
CO 4.	Determine the EMF and Torque equation of different types of Machines to solve problems based on its application	Apply
CO 5.	Select the suitable machine & working principle for a given situation and application.	Apply

Mapping with Programme Outcomes

COs	PO1	PO2	PO3	PO4	PO5	PO6	PO7	PO8	PO9	PO10	PO11	PO12
CO1	M	L	S	L	L	L	M	L	L	M	L	L
CO2	M	M	M	L	L	L	L	L	L	L	L	L
CO3	M	M	M	L	M	S	S	L	L	L	L	L
CO4	S	S	M	L	L	L	L	L	L	L	L	L
CO5	M	L	M	L	S	L	S	L	L	L	L	L

S- Strong; M-Medium; L-Low

Assessment Pattern

Bloom's Category	Continuous Assessment Tests			Terminal Examination
	1	2	3	
Remember	30	20	20	20
Understand	70	40	50	40
Apply	--	40	30	40
Analyse	--	--	--	--
Evaluate	--	--	--	--
Create	--	--	--	--

Course Level Assessment Questions

Course Outcome 1 (CO1):

1. Discuss different types of DC motor and explain any one.
2. Explain briefly Variable Reluctance principle and how stepper motor works on that principle with neat sketch.
3. Discuss in detail the difference between VRSM &PMSM.
4. Explain the principle operation of Solenoid with neat circuit diagram

Course Outcome 2 (CO2):

1. Discuss the characteristics of DC motors with neat sketches.
2. Explain the construction of Transformer with neat sketches.
3. With neat sketch briefly explain the construction of Stepper motor.

Course Outcome 3 (CO3):

1. Discuss in detail about the speed control of Induction Motors.
2. Explain the principle and operations of servo motor and give their advantages, limitations and specific applications.
3. With neat sketches, briefly explain the Principle operation of Permanent magnet stepper motor and its limitations.

Course Outcome 4 (CO4):

1. A load has impedance $10 + j 5$ and is fed by a voltage of 100V. Calculate the current and power at the load.
2. A 4 pole lap winding DC shunt generator has a useful flux per pole of 0.6Wb.The armature winding consist of 200turns, each turns having the resistance of 0.003ohm. Calculate the terminal voltage running at 1000rpm if armature current is 45Amp.
3. Derive the slip torque characteristics and equation for DC motor.

4. Derive the model of electro mechanical system.

Course Outcome 5 (CO5):

1. Select a suitable Motor and working principle for high starting torque application like
 - a. Elevator.
2. Suggest suitable design procedure along with justification for manufacture of the following
 - a. Products:
 - i. Position change application.
 - ii. House pump
3. Select the appropriate special Machine and explain the construction and working principle for Robotic application

Course Map

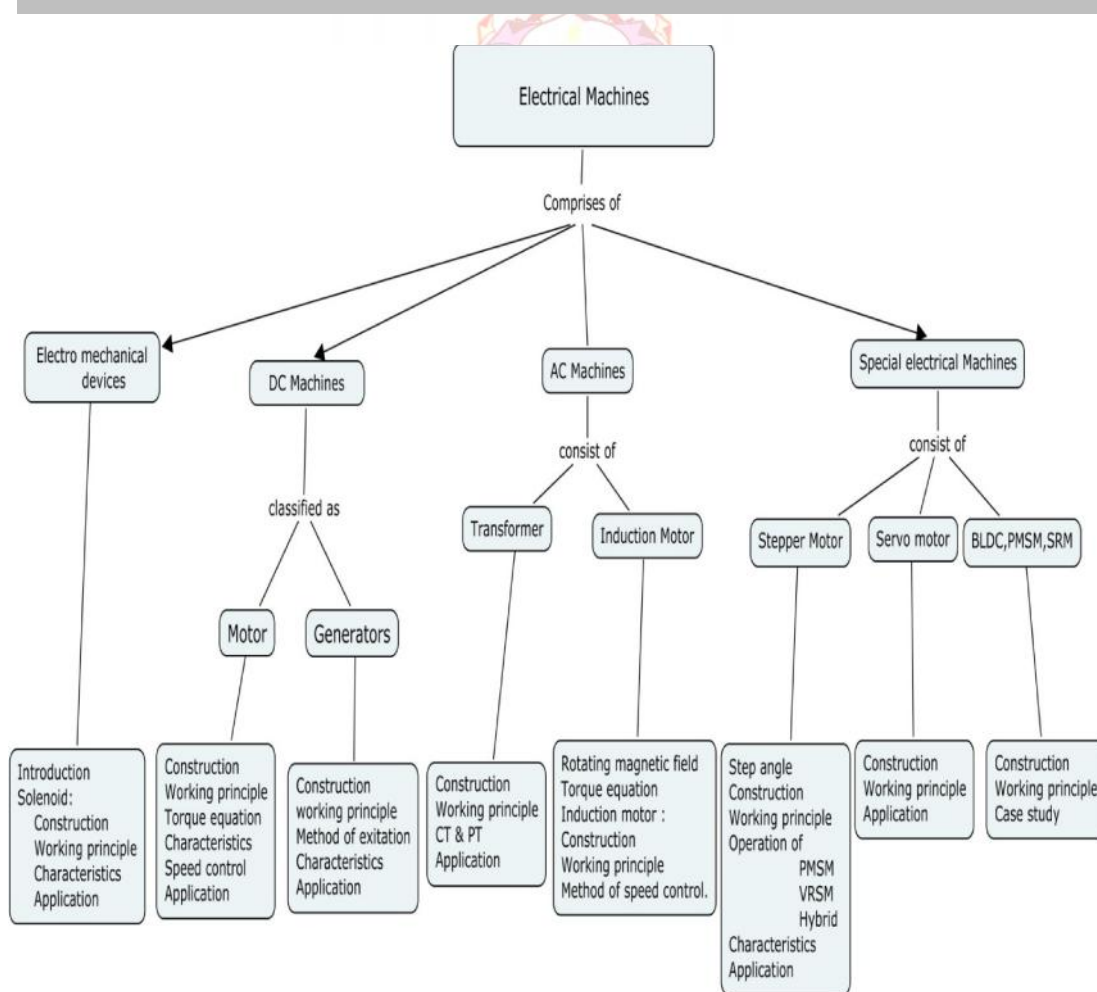

Syllabus

Introduction: Introduction to electro mechanical system – Principle of electro mechanical system – Solenoid – construction – operation principle – Characteristics - Application - Overview & importance of electrical machines.

DC Machines: Types - Constructional details – Principle & operation - Emf equation -Methods of excitation of D.C.generators - Characteristics of series, shunt generator - Principle operation of D.C. motor - Back emf and torque equation - Characteristics of series and shunt motors - Starting of D.C. motors - Speed control of D.C. motors – Applications.

Transformer: Types - Construction - Working principle - Emf equation - Voltage regulation - CT & PT - Applications.

AC Machines: Production of rotating magnetic field - Torque equation - Torque – slip characteristics - Power stages and efficiency - Principle and operation of single phase Induction motors - methods of speed control – applications.

Special Machines:

Stepper Motor: Constructional features – Step angle -Principle of operation -Variable reluctance motor –Hybrid Motor-Single and multi stack configurations – Characteristics of stepper motor.

Servo Motor: types - Construction and Working principle of Servomotor-Types-Position, speed control.

Permanent magnet DC motor, Switched reluctance motor, BLDC motor - Construction and working Principle.

Application: Application and case study of Special Machines in Mechatronics System.

Text Book

- 1) Stephen J Chapman, "**Electrical machines fundamentals**" 4th edition. Tata McGraw hill,2005
- 2) J B Gupta, "**Theory and Performances of Electrical Machines**" 14th edition SK Kataria & Sons 2010.
- 3) Takashi Kenjo, "**Stepper motor & their microprocessor control**" 2nd edition, Oxford science publication 1995.
- 4) Vedam Subramanian, "**Electric Drives**", 2nd edition, Tata McGraw Hill, 2011

Reference Books

- 1 A.E.Filtgerald & Charles Kingsley jr, "**Electric Machinery**" 6th edition,McGrow science,2002
- 2 Crowder, "**Electric Drives and Electromechanical Systems**", Elsevier, Indian Reprint, 2009.
- 3 Metha.V.K. and Rohit Metha, "**Principle of Electrical Engineering**", S.Chand & Co,2006.

Course Contents and Lecture Schedule

Module No.	Topic	No. of Lectures
1	Electro mechanical system	
1.1	Introduction, Principle of electro mechanical system	2
1.2	Solenoid – construction – operation principle	1
1.3	Characteristics - Application	1
2.	DC Machines	
2.1	Types - Constructional details – Principle & operation	2
2.2	Emf equation	1
2.3	Methods of excitation of D.C.generators	1
2.4	Characteristics of series, shunt generator	1
2.5	Principle operation of D.C. motor	1
2.6	Back emf and torque equation	1
2.7	Characteristics of series and shunt	2
2.8	Starting of D.C. motors- Speed control of D.C. motors	1
2.9	Applications	1
3	Transformer	
3.1	Types - Construction - Working principle	2
3.2	Emf equation	1

3.3	Voltage regulation	1
3.4	CT & PT – Applications	1
4	AC Machines	
4.1	Single phase	
4.1.1	Production of rotating magnetic field	1
4.1.2	Torque equation - Torque – slip characteristics	1
4.1.3	Power stages and efficiency	1
4.1.4	Principle and operation of single phase Induction motors	1
4.1.5	Methods of speed control – applications.	1
5	Special Machines	
5.1	Stepper Motor	
5.1.1	Constructional features – Step angle	1
5.1.2	Principle of operation	1
5.1.3	Variable reluctance motor	1
5.1.4	Hybrid Motor-Single and multi stack configurations	1
5.1.5	Characteristics of stepper motor	1
5.2	Servo Motor	
5.2.1	Types - Construction and Working principle of Servomotor	1
5.2.2	Types-Position, speed control	2
5.2.3	Permanent magnet DC motor - Construction and working Principle	1
5.2.4	Switched reluctance motor - Construction and working Principle	1
5.2.5	BLDC motor - Construction and working Principle	1
6	Application: Application and case study of Special Machines in Mechatronics System.	2
	Total	38

Course Designers:

- | | | |
|----|----------------|---------------|
| 1. | Dr.N.Kamaraj | nkeee@tce.edu |
| 2. | S.Julius Fusic | sjf@tce.edu |

14MT240

MATERIALS FOR MECHANICAL AND ELECTRONIC SYSTEMS

Category L T P Credit
PC 3 0 0 3

Preamble

The course work aims in imparting fundamental knowledge of materials to mechatronics engineers. The course work delivers properties of conducting, semiconducting, dielectric and magnetic materials. The types of mechanical testing and the current electronic materials such as LEDs, solar cell materials, smart materials and nanomaterials are discussed.

Prerequisite

- Course Code : 14PH120
- Course Name : PHYSICS

Course Outcomes

On the successful completion of the course, students will be able to

Mapping with Programme Outcomes

CO 1.	Compute the thermal and electrical and magnetic properties of different types of materials										Apply	
CO 2.	Interpret the basic mechanical properties and illustrate the procedure for testing of materials										Apply	
CO 3.	Compute the conductivity and bandgap of a given semiconductor for different carrier concentration and temperatures										Apply	
CO 4.	Explain the properties, structures and characteristics of materials used in LED and solar cells										Understand	
CO 5.	Explain the properties and application of new engineering materials like nano materials and shape memory alloys.										Understand	
Cos	PO1	PO2	PO3	PO4	PO5	PO6	PO7	PO8	PO9	PO10	PO11	PO12
CO1	S	M	L	L		L	L	L	L			S
CO2	S	S		S				L	L		L	S
CO3	S	L	L	S		L		M	L			S
CO4	S	L	M	M		M		L	L			S
CO5	S	L		M				L	L			S

S- Strong; M-Medium; L-Low

Assessment Pattern

Bloom's Category	Continuous Assessment Tests			Terminal Examination
	1	2	3	
Remember	20	20	20	20
Understand	30	30	30	30
Apply	50	50	50	50
Analyse	0	0	0	0
Evaluate	0	0	0	0
Create	0	0	0	0

Course Level Assessment Questions

Course Outcome 1 (CO1):

1. Write a note on the concept of hole.
2. Define dielectric breakdown and summarize the various factors contributing to breakdown in dielectrics.
3. State and prove Widemenn-Franz law. Justify the mismatch between the Lorentz member determined experimentally and theoretically.
4. A paramagnetic material has a magnetic field intensity of 10^4 A/m. If the susceptibility of the material at room temperature is 3.7×10^{-3} calculate the magnetization and flux density in the material.

Course Outcome 2 (CO2):

1. Draw a neat sketch of stress-strain diagrams showing the limit of proportionality, elastic limit, yield point, the point of maximum loading and rupture.
2. Discuss the fatigue failure of materials An Aluminium rod of 10 mm dia and 300 mm length is subjected to a tensile load of 500 kg. Calculate the tensile strain, the increase in length and decrease in diameter.
3. The Young's modulus of metal is 0.8×10^8 kg/Cm² and Poisson's ratio is 0.33.

Course Outcome 3 (CO3)

1. Write the expression for the electrical conductivity of an intrinsic semiconductor.
2. Define Fermi level in the case of semiconductors. Mention its position in intrinsic and extrinsic semiconductors at 0K.

3. Explain the variation of electrical conductivity with respect to temperature in the case of n-type semiconductor. (Understand)
4. In a Hall experiment a current of 25 A is passed through a long foil of silver which is 0.1 mm thick and 3cm wide. If the magnetic field of flux density 0.14 Wb/m^2 is applied perpendicular to the foil, calculate the hall voltage development and estimate the mobility of electrons in silver. The conductivity of silver is $6.8 \times 10^7 \text{ } \Omega^{-1}\text{m}^{-1}$ and Hall coefficient is $-8.4 \times 10^{11} \text{ m}^3/\text{coulomb}$.

Course Outcome 4 (CO4)

1. Any four properties required for a semiconductor material to be used as LED.
2. Cite any four compound semiconductors used as solar cell materials.
3. Explain the properties of Zinc Oxide which make them suitable as a solar cell material.

Course Outcome 5 (CO5)

1. Illustrate, with suitable examples, the generation of smart materials.
2. Interpret the engineering issues of the conventional shape memory alloys and advanced magnetic shape memory alloys.
3. Underline the applications of Magnetostrictive materials.

Concept Map

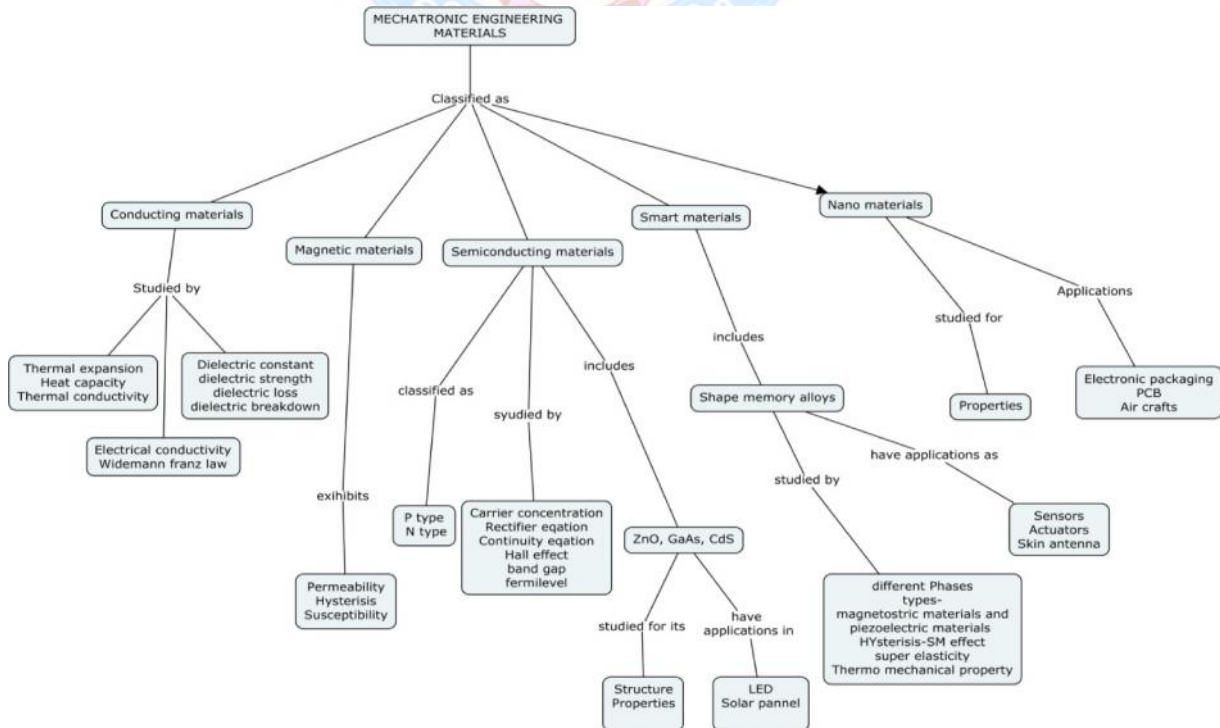

Syllabus

Properties of conducting and Magnetic Materials: Thermal Properties: Expansion, Heat Capacity and Conductivity. Electrical Properties: Conductivity, widemaan Franz law, Dielectric Constant, Dielectric Strength, Dielectric Loss and Dielectric Breakdown. Magnetic Properties: Permeability, Hysteresis, Susceptibility and Magnetic Intensity.

Mechanical properties of Materials: Classification of Materials: Selection of Engineering materials - Mechanical Properties: Concept of Stress and Strain, Elastic and Plastic Deformation, Hardness, Tensile Strength. Testing of Materials: Brinell, Vickers and Rockwell Hardness tester, Tensile test & Fatigue test. (Testing shown by demonstration on lab)

Semiconducting Materials: Classification of semiconductors – carrier Concentration in an intrinsic semiconductor – Expression for carrier concentration in n and p type semiconductors - Rectifier equation, Continuity Equation, Hall Effect - Calculation of density of holes and electrons – Fermi level and its variation with temperature – Determination of band gap, - Variation of Fermi level with temperature and impurity concentration – Structure – property and applications of ZnO, GaAs, CdS, LED materials, Solar panel materials.

Smart Materials: Classes of smart Materials – Shape Memory Alloys – Two different phases – Types of SMA – Characteristics of SMA – Hysteresis , SM effect- The phase dependence of phase change temperature upon loading, super elasticity –Thermo mechanical property - Characterization of SMA – Magnetostrictive Materials – Piezoelectric Materials – Applications: Sensors – Actuators – Skin Antenna.

Nanomaterials: Introduction - properties – Applications: electronic packaging – PCB - Aircrafts

Text Books

1. **Materials Science and Engineering – An Introduction**, William D. Callister, 6th Edition, John Wiley, USA, 2004.

Reference Books

1. **The Science and Engineering of Materials**, Donald R. Asklund and Pradeep P. Phule, 5th Edition, Cengage Learning Publisher, USA, 2006.
2. **Physics of Semiconductor Devices**, S.M. Sze and Kwok K. Ng, 3rd Edition, John Wiley, India, 2007.
3. **Solid State Physics**, S.O.Pillai, 6th Edition, New Age International Phblisher, India, 2009.

Course Contents and Lecture Schedule

Module No.	Topic	No. of Lectures
1.	Introduction to Embedded properties of conducting and magnetic materials:	
1.1	Thermal properties: Expansion, Heat capacity and conductivity	1
1.2	Derivation of thermal and electrical conductivity	2
1.3	Widemann Franz law, problems	1
1.4	Dielectric properties - Fundamental parameters	1
1.5	Dielectric loss, dielectric breakdown	2
1.6	Magnetic properties – fundamentals, domain theory of hysteresis.	2
2	Mechanical Properties of Materials:	
2.1	Classification Engineering Materials	1
2.2	Concept of Stress and Strain curve	1
2.3	Testing of Materials: Tensile Test	2
2.4	Brinell Test	2
2.5	Hardness Test	2
2.6	Fatigue Test	1
3	Semiconducting Materials	
3.1	Classification of semiconductor – carrier concentration in an intrinsic semiconductors	1
3.2	Expression for carrier concentration in n and p type semiconductors	1
3.3	Rectifier equation, continuity equation.	1
3.4	Hall effect	1
3.5	Calculation of holes and electrons	1
3.6	Determination or Band gap	1
3.7	Structure – property and applications of ZnO, GaAs, CdS	2
3.8	LED materials, Solar panel materials	1
4	Smart and Nanomaterials	
4.1	Classes of Smart Materials - Types of SMA, Characteristics of SMA	1
4.2	SM effect, Super elasticity	1
4.3	Characteristics of SRAM-Based FPGAs	1
4.4	Thermo mechanical property, Characterisation of SMA	1
4.5	Magnetostrictive materials, Piezoelectric Materials	1
4.6	Sensors, Actuators, Skin Antenna	2
4.7	Nanomaterials – Introduction, properties	1
4.8	Applications – Electronic packaging, PCB, Aircrafts	2

Course Designers:

1. Dr. S. Rajathi – srphy@tce.edu

14MT250

**ENVIRONMENTAL SCIENCE
AND ENGINEERING**

Category L T P Credit

HSS 3 0 0 3

Preamble

This course provides the basic knowledge of structure and function of ecosystem and better understanding of natural resources, biodiversity and their conservation practices. It describes the need to lead more sustainable lifestyles, to use resources more equitably. It helps to create a concern for our environment that will trigger pro-environmental action including activities we can do in our daily life to protect it. Furthermore, it deals the social issues and ethics to develop quality engineer in our country.

Prerequisite

NIL

Course Outcomes

On the successful completion of the course, students will be able to

CO 1.	Comprehend the structure and function of the ecosystem	Understand
CO 2.	Account for ecological succession of ecosystem	Understand
CO 3.	Illustrate the features of biodiversity	Apply
CO 4.	Recall the uses of natural resource	Remember
CO 5.	Recommend the solution for reduce pollution from automobiles .	Apply
CO 6.	Relate the EURO and Bharat stage norms for pollutants	Understand
CO 7.	Identify the suitable disaster management for natural calamities	Apply
CO 8.	Conserve and follow the environmental ethics and Act	Understand

Mapping with Programme Outcomes

Cos	PO1	PO2	PO3	PO4	PO5	PO6	PO7	PO8	PO9	PO10	PO11	PO12
CO1	M	L	L	L	L	S	M	M	L	L	M	M
CO2	M	L	L	L	L	M	M	M	L	L	M	M
CO3	M	L	L	L	L	M	M	M	L	L	M	M
CO4	M	L	M	L	L	S	M	M	L	L	M	M
CO5.	S	L	M	L	M	S	S	S	L	L	S	S
CO6	S	M	M	L	L	S	S	S	L	M	S	S
CO7	M	L	L	L	L	M	M	M	L	L	M	M
CO8	M	L	L	L	L	M	M	S	L	M	M	M

S- Strong; M-Medium; L-Low

Assessment Pattern

Bloom's Category	Continuous Assessment Tests			Terminal Examination
	1	2	3	
Remember	20	20	20	20
Understand	40	30	30	30
Apply	40	50	50	50
Analyse	-	-	-	-
Evaluate	-	-	-	-
Create	-	-	-	-

Course Level Assessment Questions

Course Outcome 1 (CO1):

1. Describe the multidisciplinary nature of Madurai district
2. Explain the necessity of food web
3. Account for energy of pyramid of ecosystem always upright

Course Outcome 2 (CO2):

1. List out types of ecological succession
2. Demonstrate the regulation of ecosystem
3. Illustrate process involved in transformation of natural calamity affected place to fertile land

Course Outcome 3 (CO3):

1. Demonstrate bio-geographical classification of biodiversity
2. Distinguish between in situ and ex situ conservation
3. Recall the term hot spots of biodiversity

Course Outcome 4 (CO4):

1. List uses of forest resource
2. Describe the over exploitation of natural resource
3. Report the need of social forestry

Course Outcome 5 (CO5):

1. List out the air pollutants from automobiles
2. Illustrate the consequences of air pollution
3. Identify the suitable method to reduce pollution from mechanical industries

Course Outcome 6 (CO6):

1. Define EURO and Bharath stage norms
2. Explain the salient features of EURO norms
3. Compare EURO and Bharath norms

Course Outcome 7 (CO7):

1. Define the term tsunami
2. Explain the various types of natural disaster
3. Asses the control measures of flood

Course Outcome 8 (CO8):

1. Recall the forest act in India
2. Criticise the environmental ethics of our country
3. Compare and contrast ethics and law

Concept Map

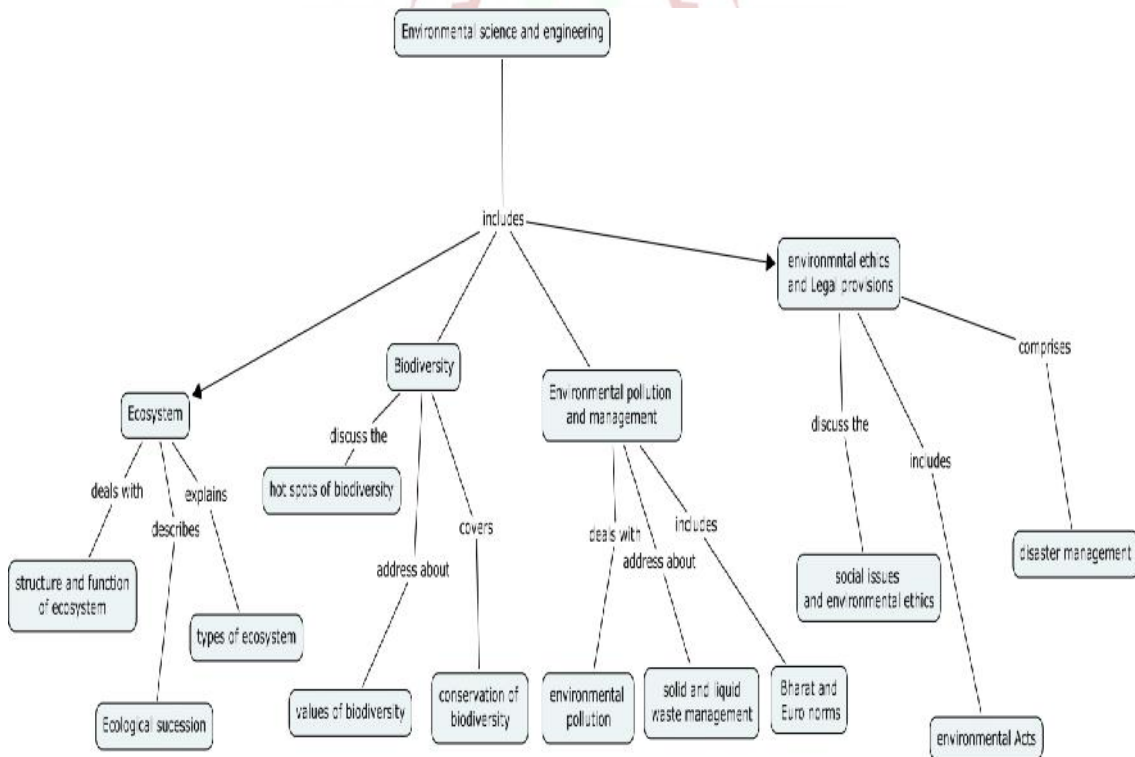

Syllabus

Ecosystem: Multidisciplinary nature of environment- need for public awareness-Eco-system- Concept, structure, function, components, laws of Ecology, Energy flow in eco system - Food chains, food webs-Ecological pyramids-Ecological succession. Types of eco system-forest, grass land, desert, aquatic ecosystem, Loss of ecosystem and its estimation.

Biodiversity: Biodiversity and its conservation-biodiversity types, bio-geographical classification, Values of biodiversity - Hot spots of biodiversity-threats to biodiversity-Biodiversity Indices-Endangered and endemic species- conservation of bio-diversity, Natural resources-Forest-Water-Food-Energy-soil-uses, over exploitation, effects and control. Role of individual in the conservation of natural resources

Environmental pollution and management: Environmental pollution- air (automobiles and mechanical industries and their case studies), water, soil and noise pollution-causes, effects and control measures, Bio fuels and alternate fuels, biopolymer composties- Radiation hazards -protection and safety- solid, liquid and e-waste management-sources – treatment & disposal. Global warming-climate change and its effect on Environment, green engineering- Euro norms- Bharath stage norms for environmental pollution, ISO 14000 standards, carbon trading.

Environmental ethics and Legal provision: Social Issues and the environment- Environmental Ethics - sustainable development - Future aspects - Human and Animal rights-conservation of ethics and traditional value systems of India - Legal provisions-Environmental acts – Air, water, soil and forest and wildlife - Population explosion and environment- family welfare programme - Value education - Disaster management- floods, earthquake, tsunami and landslides.

Learning Resources

1. Anubha Kaushik and C.P. Kaushik, **Environmental science and engineering**, third edition, New age international (p) ltd publishers.

Learning Resources

1. Eugene Odum, **Ecosystem Ecologist and Environmentalist**, paperback edition, university of Georgia press, 2002.
2. S.C. Naik, T. N. Tiwari, **Society and environment**, Oxford & IBH Publishing, 2011
3. Susmitha, R. Baskar, **Environmental science for engineering undergraduates**, Unicorn Books, 2007.
4. http://collegesat.du.ac.in/UG/Envinromental%20Studies_ebook.pdf

Course Contents and Lecture Schedule

Module No.	Topic	No. of Lectures
1.	Ecosystem	
1.1	Multidisciplinary nature of environment- need for public awareness	1
1.2	Eco-system-Concept, structure, function, components	1
1.3	Laws of Ecology and Energy flow in eco system	1
1.4	Food chains, food webs-Ecological pyramids	2
1.5	Ecological succession and regulation	1
1.6	Types of ecosystem, and their Loss and estimation	2
2.	Biodiversity	
2.1	Types of biodiversity and their bio-geographical classification	1
2.3	Hot spots of biodiversity and biodiversity indices	1
2.4	Threats to biodiversity	1
2.2	Values of biodiversity	1
2.3	Endangered and endemic species of india	2
2.4	Conservation of biodiversity	2
3	Environmental pollution and management	
3.1	Introduction to environmental pollution (air, water, soil)	1
3.2	Environmental pollution due to automobiles and industries (causes, effects and control measures)	2
3.3	Alternate fuels – bio-fuel	2
3.4	Nuclear hazardous safety and protection	1
3.5	Solid, liquid and e-waste management	2
3.6	Climatic change -Global warming and its effects	1

Module No.	Topic	No. of Lectures
3.7	Euro and bharath norms for pollution	1
4	Environmental ethics and Legal provision	
4.1	Social issues and environmental ethics	2
4.2	Sustainable development for future aspects	1
4.3	Human and animal conservation rights	1
4.4	Traditional value of India and conservation rights	2
4.5	Population explosion and environmental impact	2
4.6	Value education and disaster management	2
	Total	36

Course Designers:

1. Dr. K. Radha hodchem@tce.edu
2. Dr. S. Sivailango drssilango@tce.edu
3. Dr. V. Velkannan velkannan@tce.edu



14MT270 ANALOG AND DIGITAL DEVICES

Category	L	T	P	Credit
PC	2	0	1	3

Preamble

Signals contain information about a variety of things and activities in our physical world. An observer, be it a human or a machine, invariably needs to condition and process the signals in some predetermined manner to extract the required information. This signal conditioning/processing is usually most conveniently performed by electronic systems. For this to be possible, however, the signal must first be converted into an electrical signal, that is, a voltage or current. This process is accomplished by devices known as transducers, which can be considered as non-ideal voltage or current sources. The signals from the transducers have to be conditioned and processed as per the requirements of the application. These could involve amplification, filtering, modulation demodulation, mixing, frequency synthesizing etc. Complex analog computations can be performed on the signals if analog integrators and adders are available. In many applications the power level of the processed signal has to be increased significantly using a power amplifier to operate an actuator. While the circuits that performed these functions were designed until a few years ago using discrete active and passive components, they are now increasingly made available in integrated circuit form. However, a small percentage of these circuits have to be still designed using discrete components. Therefore, a mechatronics designer should acquire the competency of designing the discrete as well as integrated version of these signal conditioning and processing circuits. Initially these circuits were realized vacuum tubes, and since 1960s with bipolar transistors, and now with the mastering of CMOS technology all circuits both discrete and integrated versions are at present mainly designed using MOSFETS.

Prerequisite

- Course Code : Basic Electronics

Course Outcomes

On the successful completion of the course, students will be able to

CO 1.	To state the basic laws pertaining to the analog and digital system for Mechatronics application	Remember
CO 2.	Explain the components of analog and digital system and their functions	Understand
CO 3.	Select suitable analog design Techniques for mechatronic system to a given real time applications such as robot, automobile and bio-medical equipments	Apply
CO 4.	Select suitable type of digital system and design Techniques for mechatronic system to a given real time applications such as robot, automobile and bio-medical equipments	Apply

Mapping with Programme Outcomes

COs	PO1	PO2	PO3	PO4	PO5	PO6	PO7	PO8	PO9	PO10	PO11	PO12
CO1	S	M	M	L					S	S		
CO2	S	M	M	L					S	S		
CO3	S	S	S	M					S	S		
CO4	S	S	S	S					S	S		

S- Strong; M-Medium; L-Low

Assessment Pattern

Bloom's Category	Continuous Assessment Tests			Terminal Examination
	1	2	3	
Remember	10	10	10	10
Understand	40	40	40	40
Apply	50	50	50	50
Analyse	-	-	-	-
Evaluate	-	-	-	-
Create	-	-	-	-

Course Level Assessment Questions

Course Outcome 1 (CO1):

1. Write the expression of current in a diode.
2. Define cut-in voltage or barrier potential of a diode.
3. State the logic function and its truth tables.
4. Define CMRR and slew rate in an op-amp?
5. Define universal gates.
6. State demorgan's theorem.

Course Outcome 2 (CO2):

1. Explain the functioning of MOSFET as a voltage controlled resistor.
2. Explain the need for biasing in a transistor.
3. Differentiate between static and dynamic resistance of a diode.
4. Explain the reason for high CMRR in op-amp used in noisy environment.
5. Prove the demorgan's theorem.
6. Explain the functioning of Non inverting amplifier.

Course Outcome 3 (CO3):

1. Measurement of an *npn* BJT in a particular circuit shows the base current to be 14.46 μA , the emitter current to be 1.460 mA, and the base-emitter voltage to be 0.7V. Calculate α , β and I_s for these conditions?
2. In the circuit shown in the figure V_{BE} is adjusted to yield a dc collector current of 1 mA. Let $V_{CC} = 15\text{ V}$, $R_C = 10\text{ k}\Omega$, and $\beta = 100$. Find the voltage gain V_c/Bbe ? If $V_{be} = 0.005 \sin \omega t$ volts, find $v_C(t)$ and $i_B(t)$?

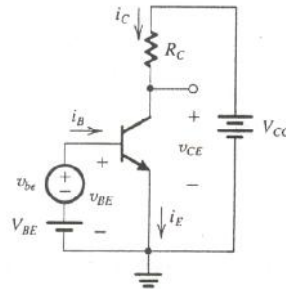

3. For the circuit shown in the figure select a value for R_B so that the transistor saturates with an overdrive factor of 10. The BJT is specified to have a minimum β of 30 and $V_{CEsat} = 0.2\text{ V}$. What is the value of forced β achieved?

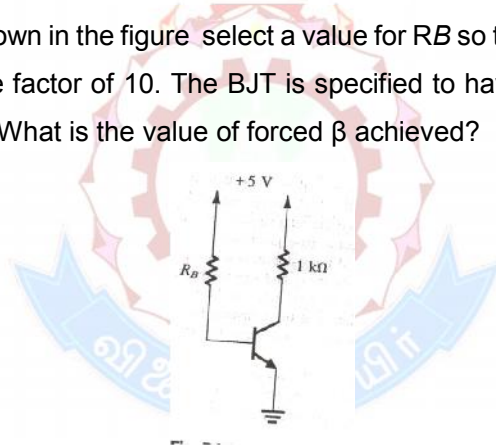

4. Find the constant of proportionality for the device whose characteristics are shown below. Also give the range of drain-source resistance corresponding to $V_{gs} = 2\text{ V}$ to 5 V . Also find the largest value that R_D can have while the MOSFET remains in saturation.

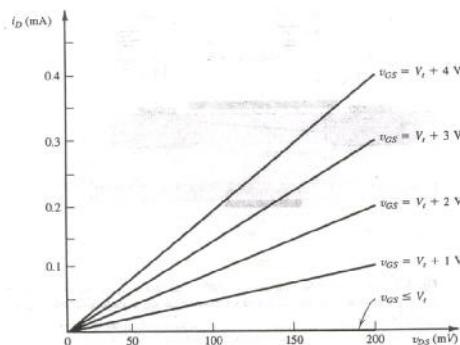

5. Consider the CMOS transmission gate and its equivalent circuit shown in the figure shown below. Let the two devices have $|V_t| = 2 \text{ V}$ and $k' (W/L) = 100 \mu\text{A}/\text{V}^2$, and let $R_L = 50 \text{ k}\Omega$. For (a) $V_A = -5 \text{ V}$, (b) $V_A = -2 \text{ V}$, and (c) $V_A = 0 \text{ V}$, calculate V_O and the total resistance of the switch?

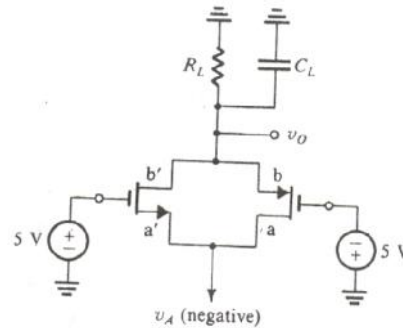

6. Consider an n -channel MOSFET with $t_{ox} = 20 \text{ nm}$, $V_t = 0.8 \text{ V}$, and $W/L = 10$. Find the drain current in the following cases:
- $v_{GS} = 5 \text{ V}$ and $v_{DS} = 1 \text{ V}$.
 - $v_{GS} = 2 \text{ V}$ and $v_{DS} = 1.2 \text{ V}$.
 - $v_{GS} = 5 \text{ V}$ and $v_{DS} = 0.2 \text{ V}$.
 - $v_{GS} = v_{DS} = 5 \text{ V}$.

Course Outcome 4 (CO4):

- Design a JK flip flop circuit and to verify its truth table.
- Design a T flip flop circuit and to verify its truth table.
- Design a up down counter circuit and to verify its truth table.
- Design a ring counter circuit and to verify its truth table.
- Design a serial in parallel out shift register and to verify its truth table.
- Design a modulo 10 counter circuit and to test its sequence.

Concept Map

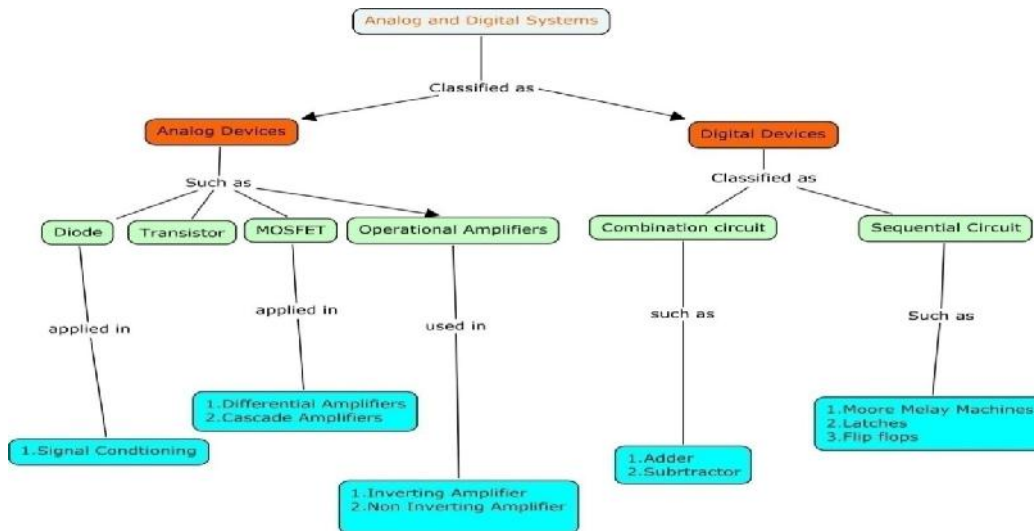

Syllabus

Analog systems: Devices for Signal Conditioning Circuits: Signal Conditioning and processing functions-Diodes (Signal, power and photo)- BJTs – JFETs – MOSFETs - CMOS

MOSFET Amplifiers: Differential Amplifiers- Cascode Amplifiers-Current Mirrors.

Op Amps and Comparators: Inverting and Non inverting function- Op Amps and comparators models of Op Amps.

Digital systems: Boolean Algebra, Logic Expressions and Truth Tables, Logic Minimization.

Combinational Functions: Multiplexing and Demultiplexing, Adders and Subtractors,

Synchronous Sequential Logic Functions : Moore and Melay Machines, Latches and Flip-Flops, State Diagrams, comparison of synchronous and asynchronous machines.

Text Books

1. Sedra and Smith, "**Microelectronic Circuits**", 5th Edition, Oxford university Press, 2004.
2. Morris Mano: **Digital Design**, Third Edition, Prentice Hall, 2001

Reference Books

1. Jacob Millman, Christos Halkias "**Integrated Electronics**" Tata Mc Graw Hill Second Edition.
2. Thomas Floyd, "**Digital Fundamentals**" Prentice Hall, 2014.

Course Contents and Lecture Schedule

No.	Topic	No. of Lectures
1	Devices for Signal Conditioning Circuits	
1.1	Diodes and its function	1
	LAB Ex: 1 VI Characteristics of Diode.	2
	LAB Ex:2 Characteristic of Zener Diode	2
1.2	BJTs as amplifiers	2
	LAB Ex: 3 I/O Characteristics of Transistor.	2
1.3	MOSFETs	1
	LAB Ex: 4 Construction of Amplifiers using Transistors.	2
	LAB Ex: 5 Construction of Transistor as a switch.	2
2	MOSFET Amplifiers	
2.1	Differential Amplifiers	1
2.2	Cascode Amplifiers-Current Mirrors	1
3	Op Amps and Comparators:	
3.1	Inverting and Non inverting function	1
3.3	Instrumentation amplifier	1
	LAB Ex: 6 Inverting and Non Inverting Operational Amplifiers.	2
	Digital systems	
4.	Advantages of processing information in digital form and Number systems	1
	Combinational Logic	
4.1	Boolean Algebra	2
4.2	Logic Expressions and Truth Tables	1
4.3	Logic Minimization	2
	LAB Ex: 7 Implementation of Logic gates and Truth table Verification.	2
	LAB Ex: 8 Implementation of universal gates and Truth table Verification.	2
5	Combinational Functions	
5.1	Multiplexers and Demultiplexers	2
5.2	Encoders and Decoders	2
5.3	Adders and Subtractors	2

	LAB Ex : 9 Construction of Half adder and Full adder using Multiplexer	2
	LAB Ex : 10 Construction of combinational functions using Multiplexer	2
6	Synchronous Sequential Logic and function	
6.1	Moore and Melay Machines	2
6.2	Latches and Flip-Flops	2
	LAB Ex : 11 Truth table verification of Flip Flops	2
	LAB Ex : 12 Truth table verification of Flip Flops	2
	Total	48

Course designer:

Dr.L.R. Karl Marx, lrkarlmarx@tce.edu



14MT280 ELECTRICAL MACHINES LAB

Category	L	T	P	Credit
PC	0	0	2	1

Preamble

The academic study of electric machines has become considerable importance in recent years. Most of the industries involve process like design, analysis, feasibility studies, installation, operation, control and maintenance of systems, plants, processes or equipment etc. This course aims to provide practical knowledge on Speed control, Load and No Load test, various characteristics of Machines.

Prerequisite

- 14MA110 : Engineering Mathematics-I
- 14PH120 : Physics
- 14ES160 : Basic electrical and electronics engineering

Syllabus

1. Characteristics of DC Machines
2. Load test on DC Motors
3. Speed control of DC motor
4. Study of Starters.
5. Load test on Single phase Transformer
6. OC/SC test on single phase Transformer
7. Load test on Induction motor
8. OC & SC test on Induction motor
9. Load test on Alternator
10. Speed control of Stepper motor.
11. Speed control of BLDC motor
12. Speed control of AC & DC Servo motor.

Course Designers:

1. Dr.N.kamaraj nkeee@tce.edu
2. S.Julius Fusic sjf@tce.edu

14ME290**WORK SHOP**

Category	L	T	P	Credit
PC	0	0	1	1

*(Common with 14ME290 Workshop/14CE290 Workshop)***Preamble**

Workshop is a hands-on training practice to Mechanical and Civil engineering students. It deals with fitting, carpentry, sheet metal and related exercises. Also, it will induce the habit of selecting right tools, planning the job and its execution.

Prerequisite

NIL

Course Outcomes

On the successful completion of the course, students will be able to:

Construct the different laminas of regular shapes.	(CO1)	Apply
Prepare the different types of fitting using MS plate.	(CO2)	Apply
Create simple sheet metal components.	(CO3)	Apply
Prepare the different types of joints using wooden material.	(CO4)	Apply

Mapping with Programme Outcomes

COs	PO1	PO2	PO3	PO4	PO5	PO6	PO7	PO8	PO9	PO10	PO11	PO12
CO1.	S	L	L	L	L	L	L	L	L	L	L	L
CO2.	S	L	S	L	L	L	L	L	L	L	L	L
CO3.	S	S	S	L	L	L	L	L	L	L	L	L
CO4.	S	L	S	L	L	L	L	L	L	L	L	L

S- Strong; M-Medium; L-Low

Syllabus**I Card Board Exercises****(4 Hours/6 periods)**

1. Construction of cube, Triangular, square, Pentagonal and Hexagonal Prisms (Any one solid)
2. Construction of Triangular, square, Pentagonal and Hexagonal Pyramids (Any one solid)

II Fitting**(6 Hours/9 periods)**

Preparation of Square, V, L, Gauge, Taper, Radius and Dove tail Fitting (Any one Fitting Exercise)

III Sheet Metal Exercises (6 Hours/9 periods)

Preparation of Liter Cone, Dust pan (Straight, Taper) and Tray (Straight, Taper) - (Any one sheet metal Exercise)

IV Carpentry (6 Hours/9 periods)

Preparation of Door frame using Mortise & Tenon joint and Mitered Mortise & Tenon joint.

V Demo on plumbing (2 Hours/3 periods)**Assessment Pattern**

All the exercises are evaluated on continuous assessment basis based on the fit/finish of the component, measurement and record. Students are given with additional attempt on each trade for their better performance (within the specified time of each trade). The distribution of marks in each trade is as follows:

Trade	Fit/Finish	Record	Total (Marks)
Card Board Exercises	15	5	20
Fitting	15	5	20
Sheet Metal	25	5	30
Carpentry	25	5	30

- **Students are evaluated based on continuous assessment only and pass mark should be minimum 50. Also no terminal examination for this course.**
- **If he/she got less than 50 marks, he/she has to undergo the terminal examination for 100 marks in subsequent semester as supplementary examination.**

Course Designers:

1. Dr. C. Paramasivam cpmech@tce.edu
2. Dr. ML. Mahadevan mlmmech@tce.edu

14MT310	FOURIER ANALYSIS AND PARTIAL DIFFERENTIAL EQUATIONS	Category	L	T	P	Credit
		BS	2	2	0	3

Preamble

The genesis of Fourier analysis is Fourier series. They are infinite series designed to represent general periodic functions in terms of simple ones, namely, cosines and sines. Fourier series are very important to the engineer and physicist because they allow the solutions of ODE's in connection with force oscillation and the approximation of periodic functions. More over Fourier analysis is applied to solve PDE's which are used to built mathematical model of many engineering problems. Many discontinuous periodic functions which come up in engineering applications can be developed in Fourier series even though they don't have Taylor series expansion. The underlying idea of Fourier series can be extended by applying Fourier series to non periodic phenomena and obtaining Fourier integral and Fourier transforms which have important applications to solve PDE's. In the digital age the discrete Fourier transforms plays an important role. Signals such as voice or music are sampled and analysed for frequencies using them.

Many physical processes fundamental to science and engineering are governed by partial differential equations (PDE) that is equations involving partial derivatives. The most familiar of these processes are heat conduction and wave propagation. To describe such phenomena, we make assumptions about gradient and we write down balance equations; PDE are those produced in a natural way. The equations of fluid flow are PDE's, and are widely used in aeronautical engineering, acoustics, study of ground water flows in civil engineering, development of fluid handling devices in mechanical engineering and investigating flame and combustion processes in chemical engineering. Stress analysis is important in large area of civil and mechanical engineering which requires a complicate set of PDE's. The goal for this course are to gain the skill of using Fourier series and Fourier transform and learning to apply Fourier series to solve PDE's. More over we aim to gain the ability to form PDE and solve them. The emphasis is to solve the heat equation and wave equation.

Prerequisite

Partial differentiation, Integral calculus.

Course Outcomes

On successful completion of the course, students will be able to

CO1:	Obtain the periodic functions arising in the study of engineering problems in terms of Sines and Cosines or complex exponentials by using Fourier series, Discrete Fourier series.	Apply
CO2:	Obtain the piece wise continuously differentiable and integrable functions arising in the study of engineering problems in terms of integral involving Sines and Cosines or complex exponentials by using Fourier transform, Sine and Cosine Fourier transform , discrete Fourier transform and Fast Fourier transform.	Apply
CO3:	Formulate and Solve Partial Differential Equations (linear, nonlinear, homogeneous and non-homogeneous) by various methods.	Apply
CO4:	Solve the boundary value problems arising in engineering problems involving one dimensional vibration problems, one dimensional heat flow problems by Fourier series.	Apply

CO5:	Solve the boundary value problems arising in engineering problems represented by two dimensional heat flow problems by Fourier series.	Apply
-------------	--	-------

COs	PO1	PO2	PO3	PO4	PO5	PO6	PO7	PO8	PO9	PO10	PO11	PO12
CO5.	S	S	S	-	-	-	-	-	-	M	-	M
CO6.	S	S	S	-	-	-	-	-	-	M	-	M
CO3	S	S	S	-	-	-	-	-	-	M	-	M
CO4	S	S	S	-	-	-	-	-	-	M	-	M
CO5.	S	S	S	-	-	-	-	-	-	M	-	M

Mapping with Programme Outcomes

Assessment Pattern

Bloom's Category	Continuous Assessment Tests			Terminal Examination
	1	2	3	
Remember	10	10	10	10
Understand	20	20	20	20
Apply	70	70	70	70
Analyse	0	0	0	0
Evaluate	0	0	0	0
Create	0	0	0	0

Course Level Assessment Questions

Course Outcome 1 (CO1):

1. Express $f(x) = x^2$ as a Fourier series of periodicity $2p$ in $-p < x < p$. Hence deduce

that (i) $\frac{1}{1^2} + \frac{1}{2^2} + \frac{1}{3^2} + \dots = \frac{p^2}{6}$, (ii) $\frac{1}{1^2} - \frac{1}{2^2} + \frac{1}{3^2} - \dots = \frac{p^2}{12}$ (iii)

$$\frac{1}{1^2} + \frac{1}{3^2} + \frac{1}{5^2} + \dots = \frac{p^2}{8}$$

2. Find the Complex form of the Fourier series for $f(x) = e^{ax}$, $-p < x < p$.
3. Find the Fourier Cosine and Sine transform of e^{-ax} .
4. Compute the first three harmonics of $f(x)$ from the following data.

x^0	0	30	60	90	120	150	180	210	240	270	300	330
$Y=f(x)$	1.8	1.1	0.3	0.16	0.5	1.3	2.16	1.25	1.3	1.52	1.76	2

Course Outcome 2 (CO2):

1. Find the Fourier transform of $e^{-|x|}$ and hence deduce that $\int_0^{\infty} \frac{\cos xt}{1+t^2} dt = \frac{\pi}{2} e^{-|x|}$
2. Prove that $F(x^n f(x)) = (-i)^n \frac{d^n F(S)}{dS^n}$
3. Show that $F_S[xf(x)] = -\frac{d}{ds}[F_C(s)]$ and $F_C[xf(x)] = \frac{d}{ds}[F_S(s)]$.
4. Find discrete time Fourier transform for unit step function and unit impulse function.
5. Find the Fourier transform of $f(x)$ defined by $f(x) = \begin{cases} 1-x^2, & |x| \leq 1 \\ 0, & \text{if } |x| > 1 \end{cases}$. And hence

prove that (i) $\int_0^{\infty} \left(\frac{\sin s - s \cos s}{s^3} \right) \cos \frac{s}{2} ds = \frac{3\pi}{6}$ (ii) $\int_0^{\infty} \left(\frac{\sin s - s \cos s}{s^3} \right)^2 ds = \frac{\pi}{15}$

Course Outcome 3 (CO3):

1. Predict the PDE by eliminating arbitrary function from $z = f\left(\frac{xy}{z}\right)$.
2. Identify the general solution for $(D^2 + D'^2)z = 0$.
3. Solve: $[D^3 - 7DD'^2 - 6D'^3]z = \sinh(2x - 3y)$.
4. Solve the equation $x^2(y - z)p + y^2(z - x)q = z^2(x - y)$.

Course Outcome 4 (CO4)

1. A taut string of length $2l$, fastened at both ends, is disturbed from its position of equilibrium by imparting to each of its points an initial velocity of magnitude $k(2lx - x^2)$. Find the displacement $y(x, t)$.
2. A taut string of length $2l$ is fastened at both ends. The midpoint of the string is taken to a height b and then released from the rest in that position. Find the displacement of the string.
3. A rod 30 cm long has its ends A and B kept at 20°C and 80°C respectively, until steady state conditions prevail. The temperature at each end is then suddenly reduced to 0°C and kept so. Find the resulting temperature function $u(x, t)$.

4. Solve the one dimensional heat flow equation $\frac{\partial u}{\partial t} = a^2 \frac{\partial^2 u}{\partial x^2}$ satisfying the following boundary conditions, (i) $\frac{\partial u}{\partial x}(0,t) = 0, \text{ for all } t \geq 0$ (ii) $\frac{\partial u}{\partial x}(l,t) = 0, \text{ for all } t \geq 0$ (iii) $u(x,0) = lx - x^2$ in $(0,l)$.

Course Outcome 5 (CO5):

1. A plate, in the form of a ring, is bounded by the lines $r = 2$ and $r = 4$. Its surfaces are insulated and the temperature along the boundaries are given by $u(2,\theta) = 10 \cos \theta + 6 \sin \theta$; $u(4,\theta) = 17 \cos \theta + 15 \sin \theta$. Find the most general form of the temperature distribution in the plate.
2. A rectangular plate of sides a and b has its faces and the edges $y = 0$ and $y = b$ insulated. If the edge $x = 0$ is kept at temperature zero, while the edge $x = a$ is kept at temperature $k(2y - b)$, find the steady state temperature distribution in the plate.
3. Along the inner boundary of a plate in the form of a circular annulus of radii 10 cm and 20cm, the temperature is maintained as $15 \cos q$ and along the outer boundary, it is maintained as $30 \sin q$. Predict the steady state temperature at any point (r, q) of the annulus.
4. An infinite long plate is bounded by two parallel edges and an end at right angles to them. The breadth is p . This end is maintained at a constant temperature u_0 at all points and the other edges are at zero temperature. Find the steady state temperature at any point of the plate.
5. A semicircular plate of radius a cm is maintained at temperature 20°C and 30°C along the boundaries $\theta = 0$ and $\theta = \pi$ respectively and at 40°C along the circumference. Find the steady state temperature distribution in the plate.

Concept Map

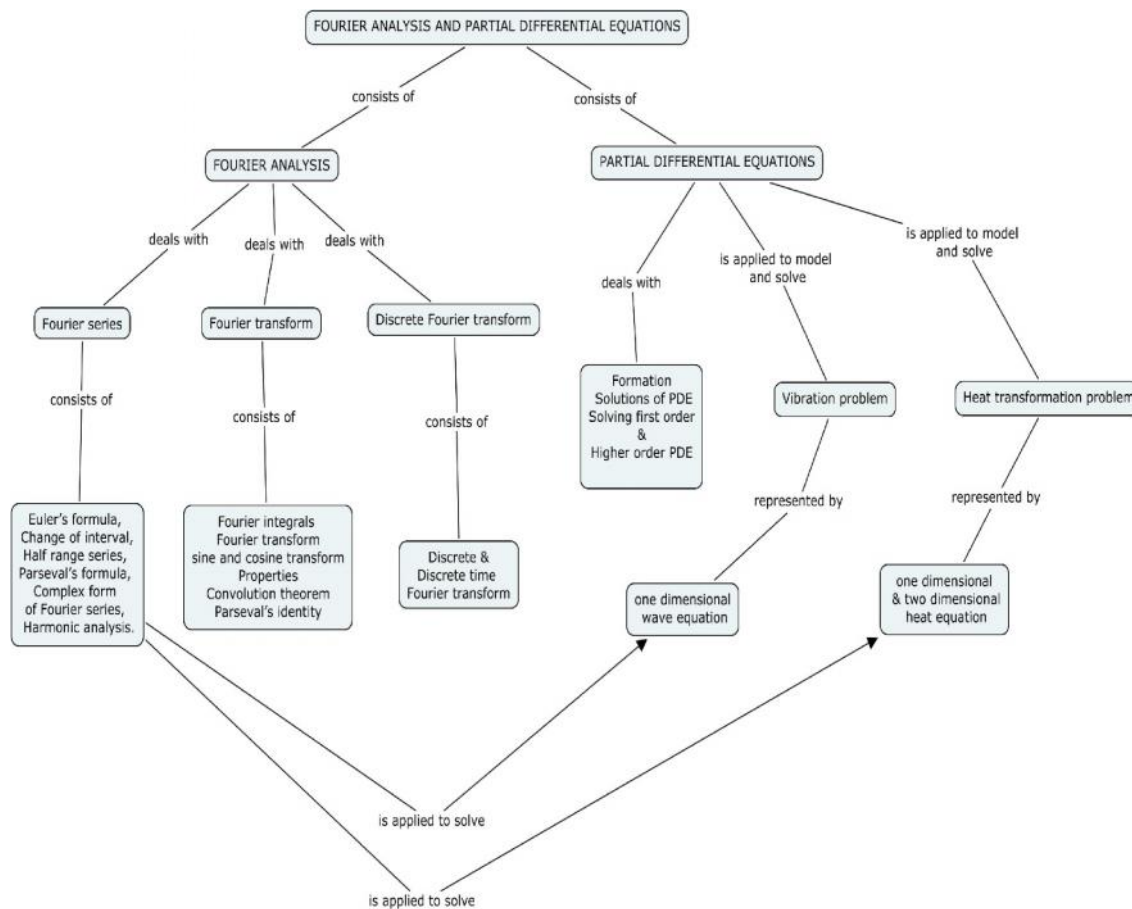

Syllabus:

Fourier Series: Conditions for Fourier expansion - Euler's formula – Functions having points of discontinuity - Change of interval - Odd and even function – Expansions of odd or even periodic functions – Half range series – Fourier series of typical wave forms - Parseval's formula – Complex form of Fourier series– Discrete Fourier series – Harmonic analysis.

Fourier transform: Fourier integrals – Fourier cosine and sine integrals(without proof) – Fourier transform – Fourier sine and cosine transform – Properties of Fourier transforms – Convolution theorem for Fourier transform – Parseval's identity for Fourier transform – Discrete Fourier transform – Discrete time Fourier transform – Fast Fourier transform.

Partial differential equations(PDE): Formation of PDE – Solutions of PDE – Equations solvable by direct integration – Linear equations of the first order – Non linear equations of the first order – Homogeneous linear equations with constant coefficients – Rules for finding the complementary functions - Rules for finding the particular integral - working procedure to solve homogeneous and non homogeneous linear equations.

Boundary value problems: Method of separation of variables – Vibrations of a stretched string – Wave equations – One dimensional heat flow problems – two dimensional heat flow problems – Solution of Laplace equation in Cartesian coordinates – Laplace equations in polar coordinates.

Text Book

1. Grewal. B.S, "**Higher Engineering Mathematics**", 41st Edition, Khanna Publications, Delhi, 2011.
2. Erwin Kreyszig, **Advanced Engineering Mathematics**, 8th Edition, John Wiley & Sons, 2009.
3. T.Veerarajan, **Engineering Mathematics**, 3rd Edition, Tata McGraw Hill, New Delhi, 2004.

Reference Books

1. Glyn James, **Advanced modern engineering mathematics**, fourth edition, Pearson education limited, 2011.
2. B.V.Ramana, **Higher Engineering Mathematics**, Tata McGraw Hill, New Delhi.

Course Contents and Lecture Schedule

Module No.	Topic	No.of Lectures
1	Fourier Series	
1.1	Conditions for Fourier expansion, Euler's formula, Functions having points of discontinuity	1
1.2	Tutorial	1
1.3	Change of interval, Odd and even function, Expansions of odd or even periodic functions	1
1.4	Tutorial	1
1.5	Half range series, Fourier series of typical wave forms, Parseval's formula	1
1.6	Tutorial	1
1.7	Complex form of Fourier series	1
1.8	Tutorial	1
1.9	Discrete Fourier series, Harmonic analysis	1
1.10	Tutorial	1
2	Fourier transform	
2.1	Fourier integrals, Fourier cosine and sine integrals(without proof's)	1
2.2	Tutorial	1
2.3	Fourier transform	1
2.4	Tutorial	1
2.5	Fourier sine and cosine transform, Properties of Fourier transforms	1
2.6	Tutorial	1
2.7	Convolution theorem for Fourier transform, Parseval's identity for Fourier transform	1
2.8	Tutorial	1
2.9	Discrete Fourier transform, Discrete time Fourier transform, Fast Fourier transform	1
2.10	Tutorial	1
3	Partial differential equations(PDE)	
3.1	Formation of PDE, Solutions of PDE	1

3.2	Tutorial	1
3.3	Equations solvable by direct integration, Linear equations of the first order, Non linear equations of the first order	1
3.4	Tutorial	1
3.5	Homogeneous linear equations with constant coefficients, Rules for finding the complementary functions	1
3.6	Tutorial	1
3.7	Rules for finding the particular integral	1
3.8	Tutorial	1
3.9	working procedure to solve homogeneous and non homogeneous linear equations	1
3.10	Tutorial	1
4	Boundary value problems	
4.1	Method of separation of variables	1
4.2	Tutorial	1
4.3	Vibrations of a stretched string, Wave equations	2
4.4	Tutorial	2
4.5	One dimensional heat flow problems with zero boundary conditions	1
4.6	Tutorial	1
4.7	Two dimensional heat flow problems with non zero boundary conditions	1
4.8	Tutorial	1
4.9	Solution of Laplace equation Cartesian coordinates	2
4.10	Tutorial	2
4.11	Laplace equations in polar coordinates	2
4.12	Tutorial	2
	Total	48

Course Designers:

- | | |
|------------------------|----------------------|
| 1. C. S. Senthil kumar | kumarstays@tce.edu |
| 2. R. Suresh | suresh080183@tce.edu |

14MT320 KINEMATICS AND DYNAMICS OF MACHINERY

 Category L T P Credit
 PC 2 2 0 3

Preamble

Kinematics is a subject which deals with relative motion between the various parts of the moving elements in a machinery. Machines are used to transform the available form of energy into other form, which transmits both force and motion to produce the specific operation. Kinematics of machines deals with the theoretical aspect such as the relative motion of the various parts of the machine. Dynamics of machinery deals with the analysis of forces and couples on the members of the machine due to external forces due to accelerations of machine elements.

Prerequisite

- Engineering Mathematics-I
- Free body Mechanics

Course Outcomes

On the successful completion of the course, students will be able to

CO 1.	Define the working principles of various mechanism and inversions	Remember
CO 2	Determine velocity and acceleration for simple mechanism	Apply
CO 3.	Construct the turning moment diagram for flywheel	Apply
CO 4.	Develop the cam profile for various types of follower	Apply
CO 5.	Identify the speed and no of tooth of gear and gear trains	Apply
CO 6.	Construct the governing differential equations and its solution for a vibrating system	Apply

Mapping with Programme Outcomes

COs	PO1	PO2	PO3	PO4	PO5	PO6	PO7	PO8	PO9	PO10	PO11	PO12
CO7.	S	S	L	L	-	-	-	-	-	-	-	-
CO8.	S	M	L	L	-	-	-	-	-	-	-	-
CO9.	M	S	L	L	-	-	-	-	-	-	-	-
CO10.	S	M	L	L	-	-	-	-	-	-	-	-
CO5.	S	M	L	L	-	-	-	-	-	-	-	-
CO6.	M	M	L	L	-	-	-	-	-	-	-	-

S- Strong; M-Medium; L-Low

Assessment Pattern

Bloom's Category	Continuous Assessment Tests			Terminal Examination
	1	2	3	
Remember	20	20	20	20
Understand	20	20	20	20
Apply	60	60	60	60
Analyse	0	0	0	0
Evaluate	0	0	0	0
create	0	0	0	0

Course Level Assessment Questions

Course outcome 1:

5. Define Kinematic Link. Give examples for Kinematic links.
6. Define kinematic pair
7. Define Kinematic chain.

Course outcome 2:

1. The crank of a slider crank mechanism rotates clockwise at a constant speed of 300rpm. The crank is 15 cm and the connecting rod is 600 mm long. Determine (a) linear velocity and acceleration of the midpoint of the connecting rod and (b) angular velocity and angular acceleration of the connecting rod at crank angle of 45° from the inner dead centre position.
2. In a four link mechanism, the dimensions of the links are $AB=200$ mm, $BC=400$ mm, $CD=450$ mm and $AD=600$ mm. At the instant when $\angle DAB=90^\circ$, the link AB has angular velocity of 36 rad/s in the clockwise direction. Determine (i) The velocity of point C, (ii) The velocity of point E on the link BC When $BE =200$ mm (iii) the angular velocities of links BC and CD, iv) acceleration of link BC.
3. The dimensions of the various links of a mechanism, as shown in fig. are as follows: $OA=300$ mm; $AB=1200$; $BC=450$ mm and $CD=450$ mm. if the crank OA rotates at 20 r.p.m. in the anticlockwise direction and gives motion to the sliding blocks B and D, find, for given configuration: (1) Velocity of sliding at B and D, (2) Angular velocity of CD (3) Linear acceleration of D and (4) angular acceleration of CD.

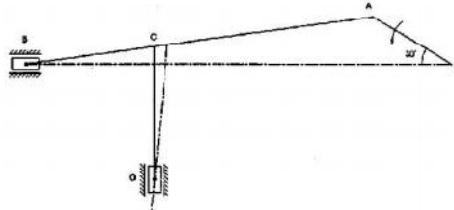

Course outcome 3:

1. The areas above and below the mean torque line for an I.C engine are -25,+200,-100,+150,-300,+150 and -75 mm^2 taken in order. The scale for the turning moment diagram is 1 mm vertical scale = 10Nm and 1 mm horizontal scale = 1.50. The mass of the rotating parts are 45 kg with a radius of gyration of 150 mm. if the engine speed is 1500 r.p.m, find the co-efficient of fluctuation of speed.
2. The turning moment diagram of an engine rotating at 200rpm is given by the relation $T(\text{kN-m})= 15 + 8 \sin 2\theta - 2 \cos 2\theta$ where θ is the crank angle. External resistance is constant. A flywheel weighing 20kN is fitted on the engine shaft so that the total fluctuation of speed does not exceed 1%.Determine the least value of moment of inertia of the fly wheel and the radius of gyration.
3. The crank and connecting rod of a vertical single cylinder gas engine running at 1800rpm are 60mm and 240mm respectively. The diameter of the piston is 80mm and the mass of the reciprocating parts is 1.2kg. At a point during the power stroke when the piston has moved 20mm from the top dead centre position, the pressure on the piston is 800kN/m^2 . Determine the
 - (i) Net force on the piston

- (ii) Thrust in the connecting rod
- (iii) Thrust on the sides of cylinder walls
- (iv) Engine speed at which the above values are zero

Course outcome 4:

1. A cam is used in a IC engine to operate the valves, is required to give a roller follower the motion defined below:
 - a. Follower to move outwards through 40 mm during 120° of cam rotation
 - b. Follower to move dwell for next 60° of cam rotation
 - c. Follower to return to its starting position during next 90° of cam rotation
 - d. Follower to dwell for the rest of the cam rotation.

The minimum radius of the cam is 50 mm and the diameter of the roller is 10mm. The line of the stroke of the follower is off-set by 20 mm from the axis of the cam shaft. The displacement of the follower takes place with uniform velocity. Create the cam profile for the given configurations. Also determine the maximum acceleration and velocity during ascent and decent when the cam rotates at 1000 r.p.m.

2. A cam is rotating clockwise at a uniform speed is required to give a roller follower the motion defined below:
 - a. Follower to move outwards through 30 mm during 120° of cam rotation ,
 - b. Follower to move dwell for next 60° of cam rotation ,
 - c. Follower to return to its starting position during next 90° of cam rotation
 - d. Follower to dwell for the rest of the cam rotation.

The minimum radius of the cam is 45 mm and the diameter of the roller is 20mm. The line of the stroke of the follower is off-set by 10 mm from the axis of the cam shaft. The displacement of the follower is to take place with simple harmonic motion on both the outward and return stroke. Create the cam profile for the given configurations. Also determine the maximum acceleration and velocity during ascent and decent when the cam rotates at 1500 r.p.m.

3. Draw the profile of a cam operating a roller reciprocating follower and with the following data: Minimum radius of cam =25 mm; lift=30mm; Roller diameter= 15mm. The cam lifts the follower for 120° with SHM, followed by a dwell period of 30°. Then the follower lowers down during 150° of cam rotation with uniform acceleration and retardation followed by a dwell period. If the cam rotates at a uniform speed of 150 RPM. Calculate the maximum velocity and acceleration of follower during the descent period.

Course outcome 5:

1. A pair of spur gear with involute teeth is to give a gear ratio of 4:1. The arc of approach is not be less than the circular pitch and the smaller wheel is the driver. The angle of pressure is 14.5. Determine
 - i) least number of teeth can be used on each wheel
 - ii) addendum of the wheel in terms of circular pitch
2. An epicyclic gear train, an arm carries two gears A and B having no of teeth 36 and 45 respectively. If the arm rotates at 150 rpm in the clockwise direction about the centre of the gear A which is fixed, determine the speed of gear B. If the gear A instead of being fixed makes 300 rpm in the clockwise direction, what will be the speed of gear B
3. A compound epicyclic gear is shown in figure. The gears A, D and E are free to rotate on axis P. The compound gears B and C rotate together on the axis Q at the end of arm F. All the gears have equal pitch. The number of external teeth on gears, A B and

C are 18, 45 and 21 respectively. The gears D and E are annulus gears. The gear A rotates at 100 rpm in anticlockwise direction and the gear D rotates at 450 rpm clockwise. Find the speed and direction of the arm and the gear E.

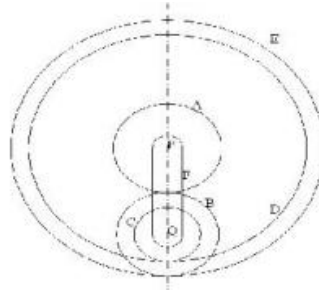

Course outcome 6:

1. A vertical shaft 100mm in diameter and 1m in length has its upper end fixed at the top as shown in figure. At the other end it carries a disc of weight 500N. The Modulus of elasticity of the material of the shaft is $2 \times 10^5 \text{ N/mm}^2$. Neglecting the weight of the shaft, determine the frequency of longitudinal vibrations and transverse vibrations.

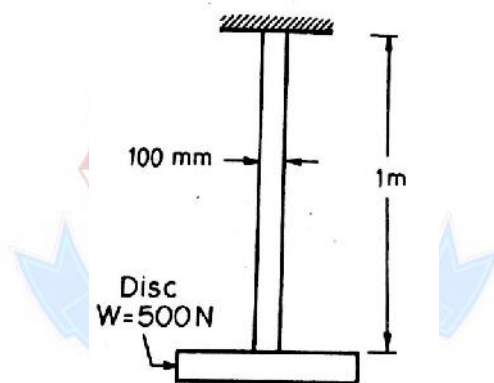

2. A Simply supported shaft of length 800mm carries a mass of 60kg placed 250mm from one end. $E=200\text{GN/m}^2$ and diameter of shaft is 50mm, then find the natural frequency of transverse vibrations.
3. A cantilever shaft 50mm diameter and 300 mm long has a disc of mass 100kg at its free end. The young's modulus for the shaft material in 200 GN/m^2 . Determine the frequency of longitudinal and transverse vibrations of the Shaft.

Concept Map

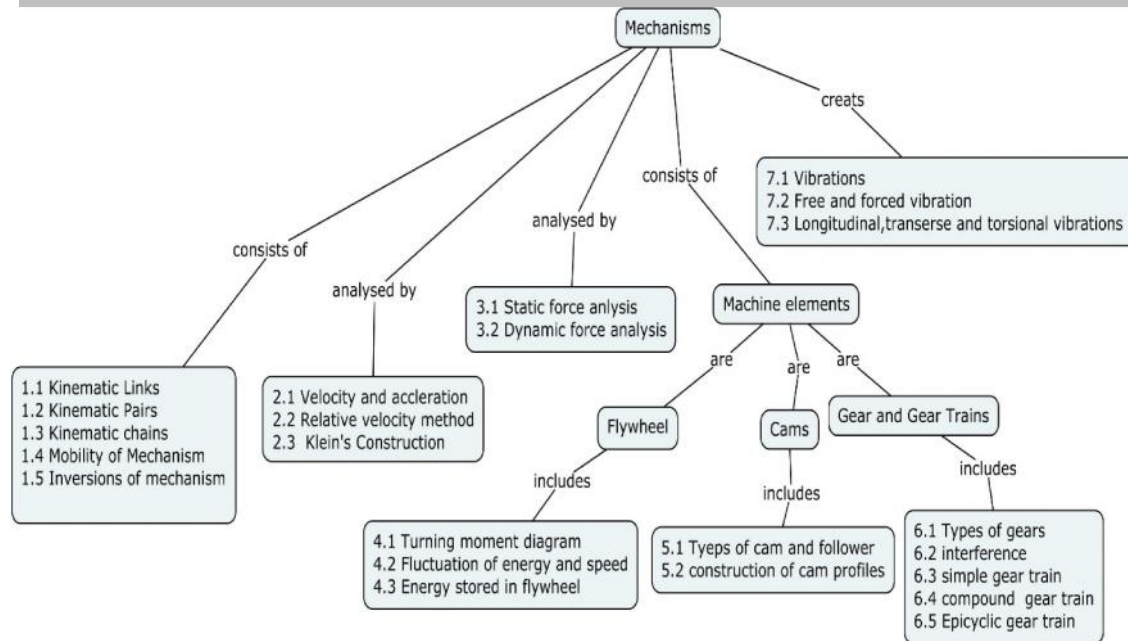

Syllabus

Elements of machines and mechanism: Introduction, Links-types, Kinematics pairs-classification, Constraints-types, Degree of Freedom, Grubler's equation, linkage mechanisms, inversions of four bar linkage, slider crank chain and double slider crank chain.

Velocity in Mechanisms: Velocity diagram - Slider Crank and Four Bar mechanism, relative velocity method

Acceleration in Mechanisms: Acceleration diagram, Slider Crank and Four Bar mechanism Klein's construction for Slider Crank mechanism

Force Analysis: Static force analysis of linkages, Equivalent offset inertia force, Dynamic analysis of slider crank mechanism.

Turning moment diagrams: Fluctuation of energy and speed, coefficient of fluctuation of energy and speed, Energy stored in a Flywheel, Dimensions of the flywheel rim.

Cams and followers: classification of cam & follower, pressure angle evaluation, cam profile for constant velocity, SHM and constant acceleration and retardation motion with knife edge and roller followers.

Gears & Gear trains: Classification, law of gearing, forms of tooth, interference, under cutting, minimum number of teeth on gear and pinion to avoid interference, contact ratio, simple, compound Epicyclic gear trains and Differential gears.

Vibrations: Introduction - Types of Vibration – Free and forced vibration, longitudinal, transverse and torsional vibrations

Text Book

1. John Joseph Uicker, Gordon Pennock, Joselph E.Shigley, “**Theory of Machines and Mechanisms**”, Third Edition, Oxford University Press, 2010.
2. Rao and Dukkupati, R.V, “**Mechanism and Machine Theory**”, New Age International (P) Ltd., 2010.
3. Rattan.S.S, “**Theory of Machines**”, Tata McGraw–Hill Publishing Co., New Delhi,2014

Reference Books

1. Thomas Bevan, “**Theory of Machines**”, CBS – Third Edition, 2010.
2. Singh, V.P., “**Theory of Machines**”, Dhanpat Rai & Co., (P) Ltd., New Delhi, 2011.
3. Sadhu Singh, “**Theory of Machines**”. Pearson Education, New Delhi, 2009.
4. Ashok G.Ambekar,” **Mechanism and Machine theory**”,Prentice Hall of India , New Delhi,2011.
5. Ballaney, P.L., “**Theory of Machines**”, Khanna Publishers, New Delhi, 2002.
6. Web resources :<http://nptel.ac.in/courses/112104121/>

Course Contents and Lecture Schedule

S.No.	Topics	No. of Lectures
1	Elements of machines and mechanism	
1.1	Kinematic link	1
1.2	Kinematic pairs	
1.3	Kinematic chains – Mechanism	1
1.4	Mobility of mechanism	1
1.5	Inversions of Four bar chain	2
1.6	Inversions of Single slider crank chain mechanisms	2
1.7	Inversions of double slider crank chain mechanisms	2
2	Velocity & Acceleration in Mechanisms:	
2.1	Relative velocity method	2
2.1.1	Velocity and acceleration of four bar mechanisms and Single slider crank chain Mechanisms	2
2.2	Klein’s construction	3
2.2.1	Velocity and acceleration of Single slider crank chain Mechanisms	
3	Force Analysis	
3.1	Static force analysis of linkages	2
3.2	Equivalent offset inertia force	
3.3	Dynamic analysis of slider crank chain mechanism. Piston and Crank effort, Inertia, Torque,	2

S.No.	Topics	No. of Lectures
4	Turning moment diagrams	
4.1	Turning moment diagrams	2
4.2	Fluctuation of energy and speed, coefficient of fluctuation of energy and speed	1
4.3	Energy stored in a Flywheel, Dimensions of the flywheel rim	3
5	Cams	
5.1	Types of cams and followers - Cam Nomenclature- Displacement, velocity and acceleration curves for various types of motions of follower- pressure angle evaluation in CAM profile	2
5.2	Construction of cam profiles- Knife edge followers - Roller follower - -Uniform Velocity Motion- Uniform Acceleration And Retardation Motion	3
6	Gear and Gear trains	
6.1	General profiles of gears-Terminology of gears and types	2
6.2	law of gearing, forms of tooth	2
6.3	Interference, under cutting	2
6.4	Minimum number of teeth on gear and pinion to avoid interference, contact ratio	2
6.5	Simple, Compound Gear trains	2
6.6	Epicyclic gear trains- Differential gears	2
7	Vibrations	
7.1	Types of Vibration	1
7.2	Free Vibration	2
7.3	Forced Vibration	2
7.4	Longitudinal, transverse and torsional vibrations	2
	Total	48 Hours

Course Designers

- | | | |
|----|--------------|---------------|
| 1. | G. Kanagaraj | gkmec@tce.edu |
| 2. | C. Vignesh | cvmec@tce.edu |

14MT330 SENSORS AND PLC

Category	L	T	P	Credit
PC	3	0	0	3

Preamble

Imagine a world without sight, sound, touch, smell, or taste. Without these sense inputs, we'd be nothing more than an inanimate machine, like the family car or the living room television, waiting for something to command us to do something. Our senses are an integral part of our lives. Similarly in machine world, in order to successfully automate a process, it is necessary to obtain information about its status. The sensors are the part of control system which is responsible for collecting and preparing process status data and for processing it into a processor. PLC is a different variant system design hardware which is currently popular in the electronic automation area.

In today's world, boundaries between different disciplines have become indistinct. In last two decades multidisciplinary approach has grown. Mechatronics is a field of engineering which deals with the integration of Mechanics and Electronics with intensive computer integration using a multidisciplinary approach to product and manufacturing system design. Hence every mechatronics engineer should understand the principle and functions of sensor and PIC based systems. The outcome of this course is to help students to acquire knowledge in understanding the sensor and PLC principles, functions and applications.

Prerequisite

- **Course Name:** Digital Electronics

Course Outcomes

On the successful completion of the course, students will be able to

CO1- Explain the function of sensor system and its method of measurements	Understand
CO2- Select a suitable sensor and implement it for given application	Apply
CO3- Exemplify the functionality along with PLC components	Understand
CO4- Develop PLC program for an application	Apply

Mapping with Programme Outcomes

COs	PO1	PO2	PO3	PO4	PO5	PO6	PO7	PO8	PO9	PO10	PO11	PO12
CO1.	L	L	L	S	S					S	L	M
CO2.	M	M	M	S	S	S	S	S	S	S	S	S
CO3.	L	L	L	S	S					S	L	L
CO4.	S	S	S	S	S	S	S	S	S	S	S	S

S- Strong; M-Medium; L-Low

Assessment Pattern

Bloom's Category	Continuous Assessment Tests			Terminal Examination
	1	2	3	
Remember	30	30	30	30
Understand	30	30	30	30
Apply	40	40	40	40
Analyse	-	-	-	-
Evaluate	-	-	-	-
Create	-	-	-	-

Course Level Assessment Questions**Course Outcome 1 (CO1):**

1. Explain the principle of strain measurement.
2. Exemplify the principle used for pressure measurement.
3. Explain the principle of temperature measurement.

Course Outcome 2 (CO2):

1. Design an signal conditioning circuit for strain gauges
2. Construct a bridge circuit for load measurements.
3. Design a cold junction compensation circuit for thermocouple.

Course Outcome 3 (CO3):

1. Explain about the architecture of PLC.
2. Explain input, output interfacing of PLC.
3. Explain about interfacing Thermocouple with PLC.

Course Outcome 4 (CO4):

1. Develop ladder program for a PLC to access timer.
2. State the way of Setting up timer ON and OFF in PLC.
3. Develop ladder program for PLC to interface analog sensor.

Concept Map

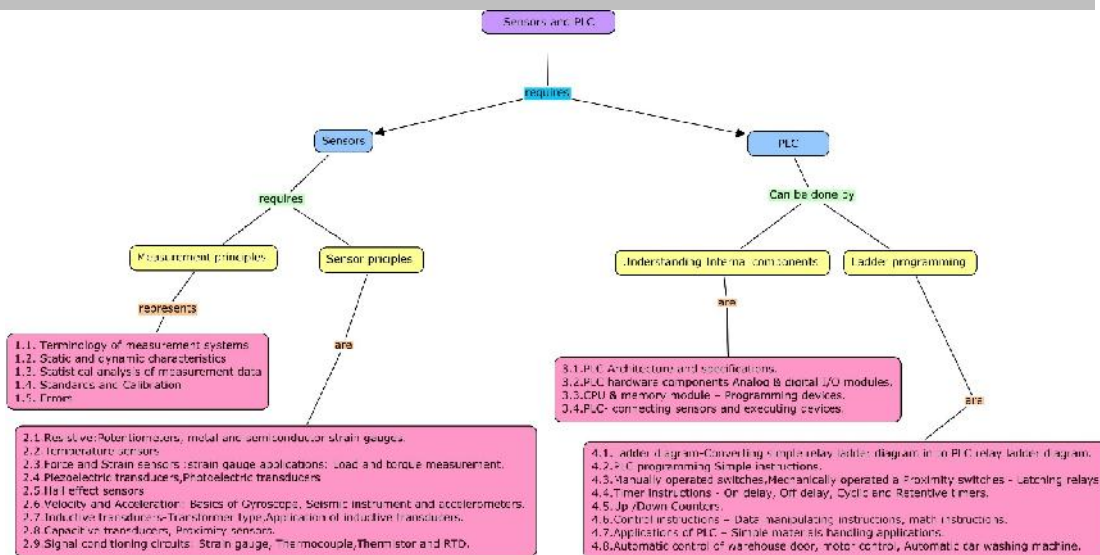

Syllabus

SENSORS

General concepts and terminology of measurement systems, transducer classification, general input-output configuration, static and dynamic characteristics of a measurement system, Statistical analysis of measurement data. Standards, Calibration and calibration errors.

Physical Principles of Sensing: Potentiometers, metal and semiconductor strain gauges, Temperature sensors **Force and Strain sensors** :Piezoelectric transducers, photoelectric transducers, Hall effect sensors, strain gauge applications: Load and torque measurement.

Signal conditioning circuits: Strain gauge, Thermocouple, Thermistor and RTD.

Velocity and Acceleration: Basics of Gyroscope, Seismic instrument and accelerometers.

Inductive transducers- Transformer type, capacitive transducers, Proximity sensors. Application of inductive transducers. Digital displacement sensors, Fibre optic sensor, Semiconductor sensor and Smart sensors. Basic application of sensors and transducers.

PLC

Programmable Logic controller: PLC and its components, Principles of operation – PLC Architecture and specifications – PLC hardware components Analog & digital I/O modules , CPU & memory module – Programming devices – PLC- connecting sensors and executing devices.

PLC Programming: Ladder diagram, Converting simple relay ladder diagram in to PLC relay ladder diagram. PLC programming Simple instructions – Manually operated switches – Mechanically operated a Proximity switches - Latching relays, Timer instructions - On delay, Off delay, Cyclic and Retentive timers, Up /Down Counters, control instructions – Data manipulating instructions, math instructions; Applications of PLC – Simple materials handling applications, Automatic control of warehouse door, motor control, Automatic car washing machine.

Text Books:

1. John P. Bentley, “Principles of Measurement Systems”, 4th Edition, Pearson Education, 2005.
2. Frank D.Petruzella, “Programmable logic controllers”, McGraw-Hill Inc.,US; 4th edition 2010.

Reference Books:

1. Murthy D. V. S, “Transducers and Instrumentation”, Prentice Hall, New Delhi, 1995
2. Neubert H.K.P, “Instrument Transducers - An Introduction to their Performance and Design”, 2nd Edition, Oxford University Press, Cambridge, 1999.
3. Patranabis, “Sensors and Transducers”, 2nd Edition, Prentice Hall India Pvt. Ltd., 2003.
4. Nebojsa Matic, “Introduction to PLC controllers”, Mikro-e Edition, Online
5. Doebelin E.O, “Measurement Systems - Application and Design”, 4th Edition, McGraw-Hill, New York, 2003.
6. S.M. Sze, “Semiconductor sensors”, John Wiley & Sons Inc., Singapore, 1994.

Course Contents and Lecture Schedule

Module No.	Topic	No. of Lectures
1.	General concepts and terminology of measurement systems	
1.1	Measurement systems basics	2
1.2	Transducer classification, general input-output configuration	1
1.3	Static and dynamic characteristics of a measurement system	1
1.4	Statistical analysis of measurement data.	2
1.5	Standards ,Calibration and Calibration errors.	2
2	Physical Principles of Sensing:	
2.1	Potentiometers, metal and semiconductor strain gauges	1
2.2	Force and Strain sensor Piezoelectric transducers, photoelectric transducers	2
2.3	Hall effect sensors, strain gauge applications: Load and torque measurement.	1
2.4	Temperature sensors.	1
2.5	Signal conditioning circuits: Strain gauge, Thermocouple, Thermistor and RTD.	2
3	Velocity and Acceleration:	
3.1	Basics of Gyroscope	1
3.2	Seismic instrument	1

Module No.	Topic	No. of Lectures
3.3	Accelerometers	1
	Inductive transducers	
3.4	Transformer type, capacitive transducers and Proximity sensors	1
4	Application of inductive transducers:	
4.1	Digital displacement sensors, Fibre optic sensor	1
3.2	Semiconductor sensor and Smart sensors..	1
3.3	Basic application of sensors and transducers	1
4	Programmable Logic controller:	
4.1	PLC and its components	1
4.2	Principles of operation – PLC	1
4.3	Architecture and specifications	1
4.4	PLC hardware components Analog & digital I/O modules	1
4.5	CPU & memory module	1
4.6	Programming devices - connecting sensors and executing devices	1
5	PLC Programming	
5.1	Ladder diagram, Converting simple relay ladder diagram in to PLC relay ladder diagram	2
5.2	PLC programming Simple instructions	1
5.3	Manually operated switches – Mechanically operated a Proximity switches - Latching relays,	1
5.4	Timer instructions - On delay, Off delay	1
5.5	Cyclic and Retentive timers, Up /Down Counters	1
5.6	Control instructions – Data manipulating instructions, math instructions	2
6	Applications of PLC	1
6.1	Simple materials handling applications, Automatic control of warehouse door	1
6.2	Motor control	1
6.3	Automatic car washing machine	1
	Total	40

Course Designers:

1. Dr. L.R.Karlmarx lrkarlmarx@tce.edu

**14MT340 THERMAL ENGINEERING AND
FLUID MECHANICS**

 Category L T P Credit
 PC 2 1 0 3

Preamble

This course aims at providing fundamental knowledge and applications in the field of thermal engineering and Fluid mechanics. The basic concepts, laws and theorem relevant to the working of thermal and fluid systems will be discussed.

Prerequisite

14ME150 Basic Mechanical Engineering

Course Outcomes

On the successful completion of the course, students will be able to

- CO 1.** Determine the properties and energy interaction in the closed and open system. Apply
- CO 2.** Determine the efficiency of heat engine and COP of heat pump and refrigerator. Apply
- CO 3.** Determine the performance parameters of an internal combustion engine and air compressor. Apply
- CO 4.** Determine the properties of fluids. Apply
- CO 5.** Apply the kinematic and dynamic concepts to fluids related to the conservation principles of mass and energy. Apply

Mapping with Programme Outcomes

COs	PO1	PO2	PO3	PO4	PO5	PO6	PO7	PO8	PO9	PO10	PO11	PO12
CO1	S	M			M		L		L		L	M
CO2	S	S			M		L		L		L	M
CO3	S	M			M		L		L		L	M
CO4	S	M			M		L		L		L	M
CO5	S	S			M		L		L		L	M

S- Strong; M-Medium; L-Low

Assessment Pattern

Bloom's Category	Continuous Assessment Tests			Terminal Examination
	1	2	3	
Remember	20	20	20	20
Understand	30	30	30	30
Apply	50	50	50	50
Analyse	--	--	--	--
Evaluate	--	--	--	--
Create	--	--	--	--

Course Level Assessment Questions

Course Outcome 1 (CO1):

1. State Zeroth law of thermodynamics.
2. Define the properties: Pressure and Temperature.
3. Distinguish between flow and non-flow system.
4. Derive the steady flow energy equation .
5. A stationary mass of gas is compressed without friction from an initial state of 0.3 m^3 and 0.105 MPa to a final state of 0.15 m^3 and 0.105 MPa , the pressure remaining constant during the process. There is a heat transfer of 37.6 kJ of heat from the gas during the process. How does the internal energy of the gas change?
6. 4 kg/s of steam enters a turbine. The inlet of the turbine is 2.5 m higher than the outlet. The velocity is 132 m/s . Outlet velocity is 327 m/s and heat loss is 9.2 kJ/s . The enthalpy per kg at inlet and outlet of the turbine are 3127.4 kJ/kg and 2512 kJ/kg respectively. Determine the power output.

Course Outcome 2 (CO2):

1. Write Kelvin Planck's statement of second law of thermodynamics.
2. Define heat engine
3. Define COP.
4. A Carnot heat engine receives heat from a reservoir at 900°C at a rate of 800 kJ/min and rejects the waste heat to the ambient air at 27°C . The entire work output of the heat engine is used to drive a refrigerator that removes heat from the refrigerated space at -5°C and transfers it to the same ambient air at 27°C . Determine (a) the maximum rate of heat removal from the refrigerated space and (b) the total rate of heat rejection to the ambient air.
5. 1200 kJ of heat is supplied to an engine from a source of 20°C , the sink temperature is 2°C . Which of the following cycle represents reversible, irreversible or impossible?
(i) 275 kJ of heat is rejected to sink, (ii) 825 kJ of heat is rejected and (iii) 350 kJ heat is rejected.

Course Outcome 3 (CO3):

1. Distinguish between brake power and indicated power.
2. Differentiate between two stroke and four stroke engine.
3. Define compressor.
4. Derive an expression for volumetric efficiency of single stage reciprocating air compressor
5. A 4-Cylinder, 2-stroke IC engine has the following particulars: engine speed = 3000 rpm , bore = 120 mm , crank radius = 60 mm , mechanical efficiency = 90% and the engine develops 75 bhp . Calculate the swept volume and mean effective pressure (MEP).
6. A single stage single acting air compressor takes in air at 1 bar and compresses it to 10 bar and delivers at a rate of 0.05 m^3 per second. If the compression and expansion follow the law $p v^{1.3} = \text{constant}$, find the power required if the clearance volume is 6% of the swept volume and the swept volume is 14500 cc . Also find the speed of compressor and volumetric efficiency.

Course Outcome 4 (CO4):

1. Define the term fluid.
2. Write Newton's law of viscosity. What is non-Newtonian fluid?
3. Derive an expression for capillary rise or fall of a liquid.
4. Determine the density, specific gravity and mass of the air in a room whose dimensions are $4 \text{ m} \times 5 \text{ m} \times 6 \text{ m}$ at 100 kPa and 15°C

- A manometer is used to measure the pressure of a gas in a tank. The fluid used has a specific gravity of 0.85, and the manometer column height is 55 cm. If the atmospheric pressure is 96 kPa, determine the absolute pressure within the tank.
- State and prove the Pascal's law.

Course Outcome 5 (CO5):

- Define steady flow.
- Derive an expression for 3D continuity equation.
- Derive Euler equation and obtain the Bernoulli's equation from it.
- The following represent the two velocity components. Determine the third component of velocity, such that they satisfy the continuity equation:

$$u = x^2 + y^2 + z^2; \quad v = xy^2 - yz^2 + xy$$

- The water is flowing through a taper pipe of length 50 m having diameters 40 cm at the upper end and 20 cm at the lower end, at the rate of 60 lps. The pipe has a slop of 1 in 40. Find the pressure at the lower end if the pressure at the higher level is 24.525 N/cm².
- Given the velocity field: $V = (6+2xy+t^2)\mathbf{i} - (xy^2+10t)\mathbf{j} + 25\mathbf{k}$. What is the acceleration of a particle at (3,0,2) at time $t = 1$?

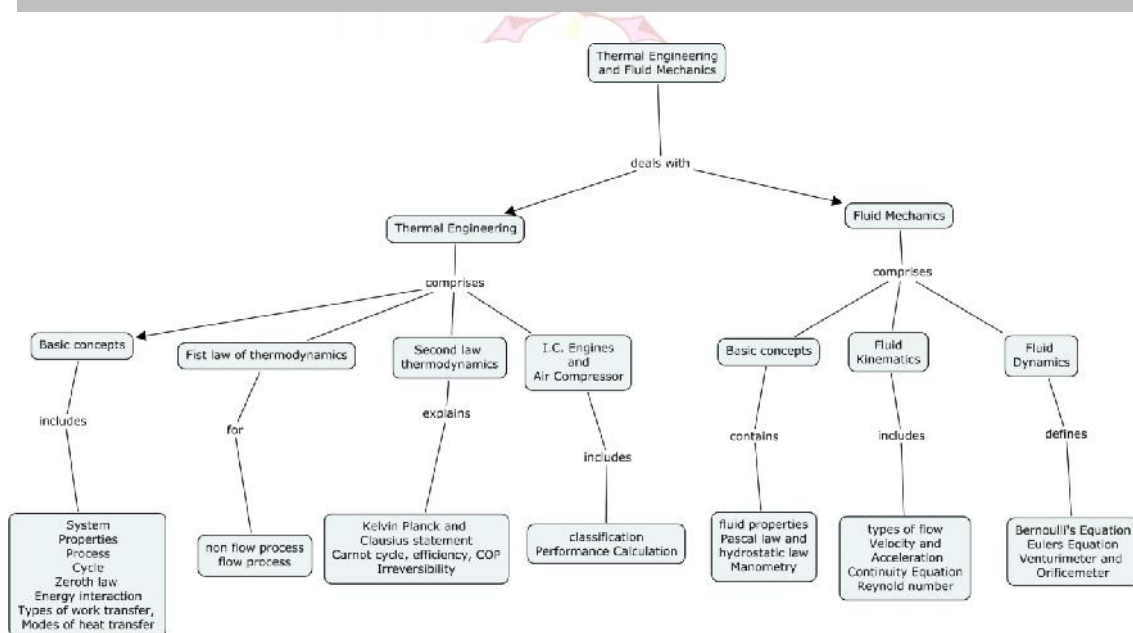
Concept Map**Syllabus**

Basic Concepts: Thermodynamic system, properties, process, cycle – Zeroth law and temperature measurement-Energy interactions: Types of work transfer and modes of heat transfer.

First Law of thermodynamics: Closed system undergoing a process and cycle- Internal energy and specific heats. Open system: Steady and unsteady flow, steady flow energy equation for nozzle, turbine, compressor, turbine and throttling device.

Second Law of thermodynamics: Kelvin Planck and Clausius Statement – Heat engine, refrigerator, Heat pump – Carnot and Reversed Carnot Engine – Efficiency and COP calculations. Concept of irreversible process and entropy

IC Engines: classification, working principle with auxiliary systems, performance calculation.

Reciprocating air compressor: single stage air compressor- working-work done with and without clearance volume – volumetric efficiency.

Basic Concepts of Fluid Mechanics: Concept of fluid - Dimensions and Units- Properties of Fluids: Pressure, Density, Specific Gravity, Viscosity, Surface Tension, Capillarity, Compressibility and Bulk Modulus.

Fluid Statics: Pressure at a Point: Pascal's Law – hydrostatic law –U- tube manometer and pressure gauge.

Fluid Kinematics: Types of flow – Velocity and Acceleration of a fluid particle - Continuity Equation in Cartesian Co-ordinates and discharge -Laminar and turbulent flow - Significance of Reynolds Number.

Fluid Dynamics: Bernoulli's Equation - Euler's Equation for Motion - Applications of Bernoulli's Equation, Venturimeter and Orifice meter.

Text Books

1. Yunus A. Cengel and Michael A. Boles, "**Thermodynamics: An Engineering Approach**", 7th Edition, McGraw Hill Education (India) Private Ltd., 2011.
2. Bruce R. Munson, Theodore H. Okiishi, Wade W. Huebsch, Rothmayer, "**Fluid Mechanics**", Seventh Edition, Wiley India Pvt. Ltd, 2015.

Reference Books

1. Rayner Joel, '**Basic Engineering Thermodynamics in SI units**', ELBS, 1998.
2. Nag, P.K., '**Engineering Thermodynamics**', Tata McGraw Hill, 2013.
3. Venkatesh, A., '**Basic Engineering Thermodynamics**', University Press, 2007.
4. Richard E. Sonntag, Claus Borgnakke, Gordon J. Vanwylen, '**Fundamental of Thermodynamics**', Wiley, 2002.
5. S. K. Som, G. Biswas, Suman Chakraborty, "**Introduction to Fluid Mechanics and Fluid Machines**", Third Edition, Tata McGraw - Hill Publishing Company Limited - New Delhi, 2011.
6. Yunus A. Cengel, John M. Cimbala, "**Fluid Mechanics: Fundamental and Applications**", Third Edition, McGraw-Hill Education (India) Pvt. Ltd, 2014.

Course Contents and Lecture Schedule

Module No.	Topic	No. of Lectures
1	Basic Concepts: Thermodynamic system, properties, process, cycle – Zeroth law and temperature measurement	3
1.1	Energy interactions: Types of work transfer and modes of heat transfer	3
2	First Law of thermodynamics: Closed system undergoing a process and cycle- Internal energy and specific heats.	5

Module No.	Topic	No. of Lectures
2.1	Open system: Steady and unsteady flow, steady flow energy equation for nozzle, turbine, compressor, turbine and throttling device.	3
3	Second Law of thermodynamics: Kelvin Planck and Clausius Statement – Heat engine, refrigerator, Heat pump.	2
3.1	Carnot and Reversed Carnot Engine – Efficiency and COP calculations-concept of irreversible process and entropy.	4
4	IC Engines: Classification and working principle with auxiliary systems.	2
4.1	Performance calculations.	2
5	Reciprocating air compressor: Single stage air compressor-working-work done with and without clearance volume – volumetric efficiency.	4
6	Basic Concepts of Fluid Mechanics: Concept of fluid - Dimensions and Units- Properties of Fluids: Pressure, Density, Specific Gravity, Viscosity	3
6.1	Surface Tension, Capillarity, Compressibility and Bulk Modulus.	2
7	Fluid Statics: Pressure at a Point: Pascal's Law – hydrostatic law –U- tube manometer and pressure gauge.	4
8	Fluid Kinematics: Types of flow – Velocity and Acceleration of a fluid particle	2
8.1	Continuity Equation in Cartesian Co-ordinates and discharge	2
8.2	Laminar and turbulent flow - Significance of Reynolds Number	2
9	Fluid Dynamics: Bernoulli's Equation - Euler's Equation for Motion - Applications of Bernoulli's Equation,	3
9.1	Venturimeter and Orifice meter	2
Total		48

Course Designers:

- | | | |
|----|------------|-----------------------|
| 1. | K. Srithar | ponsathya@hotmail.com |
| 2. | P. Maran | pmmech@tce.edu |

14MT350 MANUFACTURING PROCESSES

PC 3 0 0 3

Preamble

The basic processes used for manufacturing desired shape of a product are casting, forming, machining, and joining processes. Casting is a manufacturing process by which a liquid material is usually poured into a mould, which contains a hollow cavity of the desired shape, and then allowed to solidify. The solidified part is also known as a casting, which is ejected or broken out of the mould to complete the process.

Forming or metal forming, is the metalworking process of fashioning metal parts and objects through mechanical deformation; the work piece is reshaped without adding or removing material, and its mass remains unchanged.

Welding is a fabrication or sculptural process that joins materials, usually metals or thermoplastics, by causing coalescence. This is in contrast with soldering and brazing, which involve melting a lower-melting-point material between the work pieces to form a bond between them, without melting the work pieces.

Machining is a term used to describe a variety of material removal processes in which a cutting tool removes unwanted material from a work piece to produce the desired shape. The work piece is typically cut from a larger piece of stock, which is available in a variety of standard shapes, such as flat sheets, solid bars, hollow tubes, and shaped beams.

The first, second, third and fourth parts of this course aim to provide knowledge on the working principles, basic operations and applications of various metal casting, forming, joining and machining processes

Prerequisite

- 14ES150 : Basics of Civil and Mechanical Engineering

Course Outcomes

On successful completion of the course, students will be able to

CO 1.	Explain the principle, types and various operations of metal casting, metal forming, metal joining and machining processes.	Understand
CO 2.	Explain the process capabilities of various metal casting, metal forming, metal joining and machining processes.	Understand
CO 3.	Select the suitable metal casting and forming processes for a given product or component.	Apply
CO 4.	Suggest the suitable joining methods for fabrication / assembly of product.	Apply
CO 5.	Select a suitable process for machining of a given part.	Apply

Mapping with Programme Outcomes

Cos	PO1	PO2	PO3	PO4	PO5	PO6	PO7	PO8	PO9	PO10	PO11	PO12
CO1.	S	-	-	-	-	-	-	-	-	-	L	-
CO2.	S	-	-	-	-	-	-	-	-	-	L	-
CO3.	S	-	-	-	-	-	-	-	-	-	M	-
CO4.	S	M	L	-	-	-	-	-	-	-	M	-
CO5.	S	M	L	-	-	-	M	-	-	-	M	-

S- Strong; M-Medium; L-Low

Assessment Pattern

Bloom's Category	Continuous Assessment Tests			Terminal Examination
	1	2	3	
Remember	20	20	20	20
Understand	40	40	40	40
Apply	40	40	40	40
Analyse	0	0	0	0
Evaluate	0	0	0	0
Create	0	0	0	0

Course Level Assessment Questions

Course Outcome 1 (CO1):

8. Give the classification of welding processes.
9. Define impact extrusion.
10. Write down any four operations performed by a shaper.

Course Outcome 2 (CO2):

11. Discuss the steps involved in investment mould casting process with neat sketches.
12. Explain with neat sketches the following forging operations: (a) upsetting, (b) drawing down, (c) bending, (d) drifting, (e) punching, (f) fullering, (g) heading and (i) piercing
13. Describe in details about the principle of operations of Electron beam machining (EBM).

Course Outcome 3 (CO3):

14. Select a suitable pressure die casting process for low melting point materials.
15. Suggest suitable metal forming process along with justification for manufacture of the following products:
 - (i). CAM shaft of IC Engine
 - (ii). Threaded bolt
 - (iii). Spur gears of AI
16. How is the following house hold articles produced? i) Tumblers and ii) Cups

Course Outcome 4 (CO4):

17. Suggest the suitable joining process for the manufacture of i) funnel made of MS sheet of 22 Gauge thickness and ii) PCB used in electronic products.
18. Suggest the suitable welding process for the following: i) Cast iron; ii) Aluminium alloy.
19. Select a suitable process to weld air craft body and explain with necessary sketches.

Course Outcome 5 (CO5):

20. How do you select a grinding wheel for the following materials?
 - (i).Aluminium
 - (ii). Copper
 - (iii) Steels
21. The part shown in the accompanying figure is a power-transmitting shaft; it is to be produced on a lathe. List the operations that are appropriate to make this part.

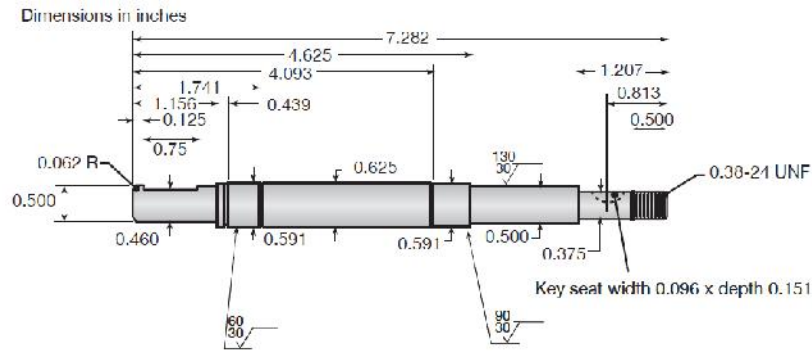

22. Sketch and describe the details of a broach used to machine an internal hole of Φ 10 mm diameter of specimen of size 250 x 150 x 25 mm.

Concept Map

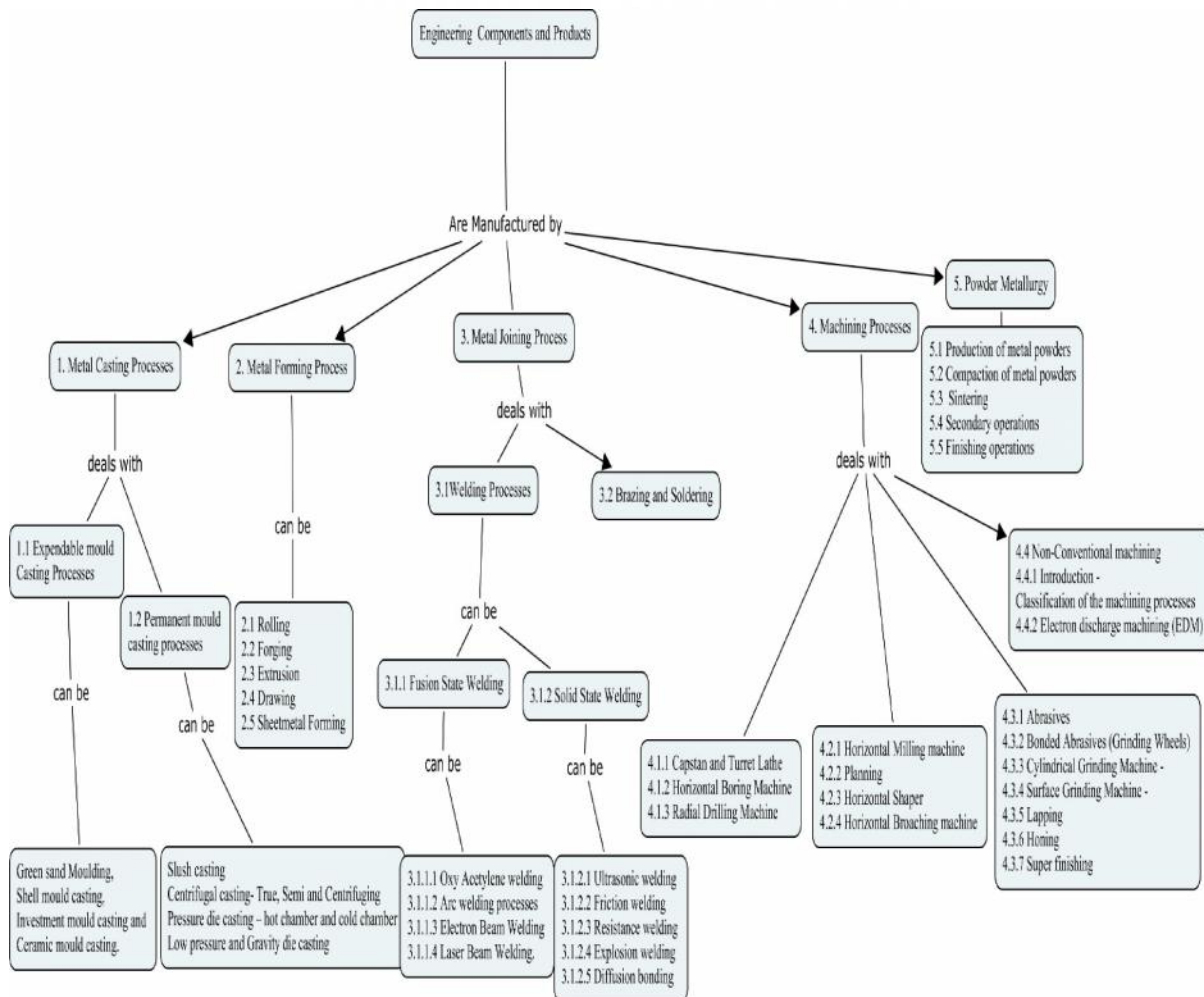

Syllabus

(Working principles, Basic operations & Applications only)

Metal Casting Processes: Expendable mould Casting Processes -Sand Casting - Shell moulding – Plaster Mould casting – Ceramic mould casting – Investment casting – Permanent Mold casting Processes – Slush casting – Pressure casting - Die casting - Centrifugal casting.

Metal Forming Processes: Flat Rolling – Flat Rolling Practice –Rolling Mills – Shape Rolling operations – Production of seamless tubing and pipe – Forging –Open die forging – Impression Die and Closed die forging – Related forging operations – Extrusion - Hot extrusion – Cold extrusion – Impact extrusion – Hydrostatic extrusion and Rod and Wire Drawing.

Sheet metal forming Processes: Shearing – Sheet Metal characteristics – Bending sheet and plate and Cup Drawing.

Metal Joining Processes: Fusion Welding Processes-Oxy Acetylene welding - Arc welding processes: Consumable Electrode and Non consumable Electrode – Electron Beam Welding – Laser Beam Welding. Solid State Welding Processes:- Ultrasonic welding – Friction welding – Resistance welding.

Brazing, Soldering: Introduction to Brazing and Soldering

Machining processes for producing Round shapes: Capstan and Turret Lathe – Horizontal Boring Machine – Radial Drilling Machine.

Machining processes for producing various shape: Horizontal Milling machine – Shaper – Horizontal Broaching machine.

Abrasive machining and finishing processes: Abrasives – Bonded Abrasives (Grinding Wheels) – Cylindrical Grinding Machine - Surface Grinding Machine - Lapping – Honing - Super finishing.

Non-Conventional machining

Introduction - Classification of the machining processes- Electric discharge machining (EDM).

Text Book

1. Serope Kalpakjian and Steven R.Schmid, “**Manufacturing Engineering and Technology**”, Sixth Edition, PHI, 2010.
2. Mikell P.Groover “**Fundamental of Modern Manufacturing**”, Wiley India Edition, Third Edition, Reprint, 2012.

Reference Books

6. E. Paul DeGarmo, J. T. Black and Ronald A. Kohser, “**Degarmo’s Materials and Processes in Manufacturing**”, John Wiley & Sons, 11th Edition 2011.
7. Philip F. Oswald, and Jairo Munoz, “**Manufacturing Process and systems**”, John Wiley India Edition, 9th Edition, Reprint 2008.
8. S. K. Hajra Choudhury, Nirjhar Roy, A. K. Hajra Choudhury, “**Elements of Work shop Technology**”, Vol – II Manufacturing Processes, Media Promoters and Publishers Pvt. Ltd, 2009.

9. P.N.Rao, “**Manufacturing Technology**”, Volume-2, Tata McGraw Hill, New Delhi, Third Edition, 2011.
10. P.C. Sharma, “**A Text Book of Production Technology (Manufacturing Processes)**”, S. Chand & Company Ltd., New Delhi, Seventh Reprint, 2012.

Course Contents and Lecture Schedule

Module No.	Topic	No. of Lectures
1	Metal casting Processes	
1.1	Expendable mould Casting Processes -Sand Casting	2
1.2	Shell moulding – Plaster Mould casting	1
1.3	Ceramic mould casting – Investment casting	1
1.4	Permanent Mould casting Processes – Slush casting	1
1.5	Pressure casting – Die casting – Centrifugal casting	2
2	Metal Forming Processes	
2.1	Flat Rolling – Flat Rolling Practice	2
2.1.1	Rolling Mills, Shape Rolling operations	2
2.1.2	Production of seamless tubing and pipe	1
2.2	Forging –Open die forging	1
2.2.1	Impression Die and Closed die forging	2
2.2.2	Related forging operations	1
2.3	Extrusion- Hot extrusion – Cold extrusion Impact extrusion	2
2.3.1	Hydrostatic extrusion and Rod and Wire Drawing	1
2.4	Sheet metal forming Processes: Shearing	1
2.4.1	Sheet Metal characteristics – Bending sheet and plate and Cup Drawing	1
3	Metal Joining Processes	
3.1	Fusion Welding Processes-Oxy Acetylene welding	1
3..1.1	Arc welding processes: Consumable Electrode and Non consumable Electrode	1
3.1.2	Electron Beam Welding – Laser Beam Welding.	1

3.2	Solid State Welding Processes:- Ultrasonic welding	1
3.2.1	Friction welding – Resistance welding	2
3.3	Introduction to Brazing and Soldering	1
4	Machining Processes	
4.1	Machining processes for producing Round shapes- Capstan and Turret Lathe	1
4.1.1	Horizontal Boring Machine	1
4.1.2	Radial Drilling Machine	1
4.2	Machining processes for producing various shape	
4.2.1	Horizontal Milling machine	2
4.2.2	Shaper	1
4.2.3	Horizontal Broaching machine.	1
4.3	Abrasive machining and Finishing processes	
4.3.1	Abrasives – Bonded Abrasives (Grinding Wheels)	1
4.3.2	Cylindrical Grinding Machine - Surface Grinding Machine	1
4.3.3	Lapping – Honing - Super finishing	2
4.4	Non-Conventional machining	
4.4.1	Introduction - Classification of the machining processes- Electric discharge machining (EDM)	1

Total 36 Hours

Course Designers:

1. PL. K. Palaniappan kpal@tce.edu
2. J. Umar Mohamed umar_tce_mech@tce.edu

14MT370

**PROBLEM SOLVING USING
COMPUTER**

Category	L	T	P	Credit
PC	2	0	2	3

Preamble

This syllabus is intended for the candidate who desires to learn problem-solving techniques and the design of computer solutions in a precise manner. The syllabus emphasizes problem-solving methodologies, algorithm designs and developments and computer-programming skills. The intention is to provide sufficient depth in these topics to enable candidates to achieve better understanding of problem solving using computers. Besides the written papers, lab-based examinations are included as part of the assessment requirements for the study. The lab-based examinations will test the candidate's ability to develop computer-programming solutions for a series of programming tasks of varying complexity.

The modules in the syllabus reflect solving general problems via programming solution. Thus, modules collectively focus on programming concepts, strategies and techniques; and the application of these toward the development of programming solutions.

Prerequisite

- Nil

Course Outcomes

On successful completion of the course, students will be able to

- | | | |
|------|--|-------|
| CO1. | Construct algorithms for solving simple mathematical and engineering problems using appropriate control structures like repetition and selection. | Apply |
| CO2. | Build flow charts for modelling solutions to solve numerical and engineering problems. | Apply |
| CO3. | Construct solutions for problems related to merging, searching, sorting and string manipulation using either iteration or recursion as applicable. | Apply |
| CO4. | Construct solutions involving structures to store, manipulate and retrieve records of data. | Apply |

Mapping with Programme Outcomes

Cos	PO1	PO2	PO3	PO4	PO5	PO6	PO7	PO8	PO9	PO10	PO11	PO12
CO1.	S	S	M	-	-	-	-	-	M	-	-	M
CO2.	S	S	M	-	-	-	-	-	M	-	-	M
CO3.	S	S	M	-	-	-	-	-	M	-	-	M
CO4.	S	S	M	-	-	-	-	-	M	-	-	M

S- Strong; M-Medium; L-Low

Assessment Pattern

Theory (70 marks)				Practical (30 marks)		
Bloom's Category	Continuous Assessment Tests (20)		Terminal Examination (50)	Valuation category	Continuous Assessment (10)	Continuous Assessment Test 3 (20)
	1	2				
Remember	20	20	20	Class work/ Exercise	90	90
Understand	20	20	20	Record / Viva-voce	10	10
Apply	60	60	60			
Analyse	0	0	0			
Evaluate	0	0	0			
Create	0	0	0			

* Theory Cum Practical Courses:

There shall be three continuous assessment tests: the first two tests (Maximum 50 marks for each test) will be from theory component and the third test (Maximum 50 Marks) will be for practical component. The sum of marks of first two tests shall be reduced to 20 Marks and the third test mark shall be reduced to 20 marks. Average mark awarded for viva – voce, conduct of experiments, observation & results, record work in regular class work shall be reduced to 10 marks. The sum of these 50 Marks would be rounded to the nearest integer.

Course Level Assessment Questions

Course Outcome 1 (CO1):

1. Recall the list of symbols used in flowcharts for various purposes. (Remember)
2. Summarize the steps involved in exchanging values of variables. (Understand)
Choose proper selection control structures to solve area of rectangle, triangle and circle. (Apply)

Course Outcome 2 (CO2):

1. What is the use of an array? (Remember)
2. Compare function call and recursive call. (Understand)
3. Make use of arrays and functions to transpose an mxn matrix. (Apply)
Analyze the performance of search algorithms. (Analyze)

Course Outcome 3 (CO3):

1. What is text processing?
2. Explain the algorithm for linear pattern searching
Develop an algorithm for comparing two strings.

Course Outcome 4 (CO4):

1. Develop a C program to convert decimal to binary of a given number using non recursive and recursive techniques. (Apply)
2. Develop a C program to multiply two nxn matrices using arrays and pointers. (Apply)

3. Develop a C program to create a text file to store records of addresses of N persons and retrieve and display the records with city="Madurai". (Apply)

Concept Map

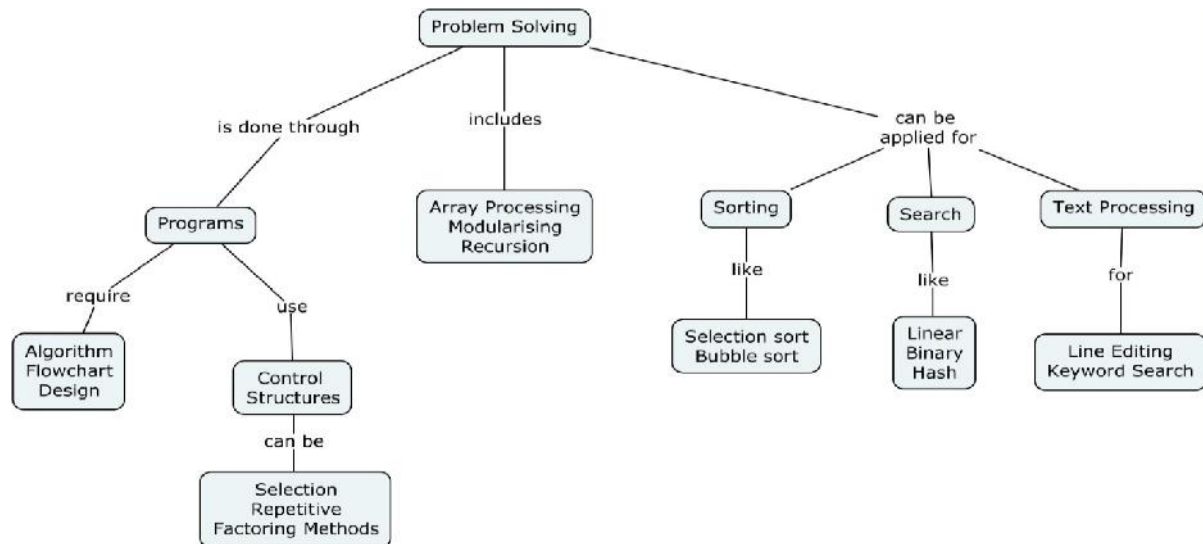

Syllabus

Theory Component:

Introduction to Computer. Computer architecture. Basics of operating system. Problem Solving - Introduction to Computer - Program Design - Developing an Algorithm – Flowcharts - Efficiency of algorithms - Analysis of algorithms - Fundamentals Algorithms - Exchanging values of variables – Counting. Control structures - Selection Control Structures - Repetition Control Structures - Summation of set of numbers - Factorial computation - Sine function computation - Fibonacci sequence generation - Reversing the digits of an Integer - Base conversion - Character to number conversion. Factoring Methods - Finding square root of a number -The smallest divisor of an integer Generating Prime numbers - Generating Pseudo-random numbers - Computing n^{th} Fibonacci number. Array Processing and Techniques - Array technique - Finding the maximum number in a set - Finding k^{th} smallest number - Removal of duplicates from an ordered array - Partitioning array - Matrix manipulations - Modularization and recursion - Sorting by selection. Text Processing - String Manipulations – Structures – Union.

Text Books

1. R.G Dromey, "**How to solve it by Computer?**", Pearson education, Delhi, 2008.
2. Lesley Anne Robertson, "**Simple Program Design, A Step-by-Step Approach**", 5th Edition, Thomson, 2007.

Reference Books

11. Yashavant P. Kanetkar, "**Let us C**", 12th edition, BPB Publications, 2012.
12. Daniel Weller, ocw.mit.edu/courses/electrical-engineering-and-computer-science/6-087-practical-programming-in-c-january-iap-2010/download-course-materials.
13. C Programming Examples – URL: www.programmingsimplified.com

14. NPTEL Video Lectures – Introduction to Programming in C, Prof. Satyadev Nandakumar, IIT Kanpur. URL: www.nptel.ac.in/courses/106104128.

Course Contents and Lecture Schedule for Theory

Module No.	Topic	No. of Lectures
1	Introduction to Computer Problem Solving	
1.1	Introduction to Computer, Computer architecture Program Design, Developing an Algorithm, Basics of operating system	3
1.2	Flowcharts	1
1.3	Efficiency of algorithms, Analysis of algorithms	2
1.4	Fundamentals Algorithms	1
1.5	Exchanging values of variables, Counting	1
2	Control structures	
2.1	Selection Control Structures, Repetition Control Structures	1
2.1.1	Summation of set of numbers, Factorial computation, Sine function computation	2
2.1.2	Fibonacci sequence generation, Reversing the digits of an Integer	1
2.1.3	Base conversion, Character to number conversion	1
2.2	Factoring Methods	
2.2.1	Finding square root of a number, The smallest divisor of an integer	1
2.2.2	Generating Prime numbers	1
2.2.3	Generating Pseudo-random numbers, Computing n th Fibonacci number	1
3	Array Processing and Techniques	
3.1.1	Array technique, Finding the maximum number in a set, Finding k th smallest number	2
3.1.2	Removal of duplicates from an ordered array, Partitioning array,	1
3.2	Matrix manipulations (add, subtract, multiply)	2
3.3	Modularization and recursion, Sorting by selection,	1
4	Text Processing	
4.1	String Manipulations	1
4.2	Structures	2
4.2.1	Union	1
	Total	26

Syllabus

Practical Component:

Problem Solving with Fundamental Algorithms (use data types and expressions)

Problem solving with Selection Control Structures and Decision Statements (use if-else, switch-case, break, and continue)

Problem solving with Repetition Control Structures and Loop Statements (use while, do-while and for loops)

Problem solving with array based problems (use 1D and 2D arrays) and function oriented problems (functions and recursive functions)

Problem solving using text and strings (use string, structures)

Course Contents and Lecture Schedule for Practical Component

Module No.	Topic	No. of Lectures
1	Introduction to C components	1
2	Problems on Fundamentals Algorithms	2
3	Factoring Methods in C	2
4	Problems on Factoring Methods	2
5	Selection Control Structures, Repetition Control Structures in C	2
6	Problems on Selection Control Structures, Repetition Control Structures	2
7	Array techniques in C	2
8	Problems on Array techniques	2
9	Functions and recursion in C	1
10	Problems on Functions and recursion	2
11	Concepts of String in C	1
12	Problems on Strings	2
13	Concepts of structures in C	1
14	Problems on structures	2
	Total	24

Course Designers:

1. S. Sudha ssj@tce.edu
2. S. Prasanna sprcse@tce.edu

14MT380 THERMAL ENGINEERING LAB

Category	L	T	P	Credit
PC	0	0	2	1

Preamble.

The laboratory exercises aim at providing practical knowledge in thermal systems such as IC engines, compressor, refrigerator, heat pump, heat transfer equipments and measuring devices.

Prerequisite

- 14 ME150 Basic Civil and Mechanical Engineering

Course Outcomes

CO1	Determine the performance of internal combustion engine and the concentration of pollutants from petrol and diesel engine exhaust	Apply
CO2	Determine the performance of refrigerator	Apply
CO3	Determine the efficiency of a steam generator	Apply
CO4	Determine thermal conductivity and natural convection heat transfer coefficient	Apply
CO5	Determine the mass flow rate of air supplied by a compressor or engine using an orifice meter	Apply
CO6	Determination of viscosity and density of incompressible fluid	Apply

On successful completion of the course, students will be able to

Syllabus**List of Experiments**

1. Performance test on single cylinder 4-stroke Diesel engine at constant speed.
2. Determination of friction power of Diesel engine using retardation test
3. Determination of friction power of 4-stroke constant speed Diesel engine using Willan's line method.
4. Determination of volumetric efficiency test on a 4-stroke Diesel engine.
5. Determination of valve timing diagram on a 4-stroke engine
6. Determination of port timing diagram on a 2-stroke model engine
7. Emission analysis on Petrol engine exhaust and Diesel engine exhaust
8. Energy balance test on Diesel engine using airflow measurement method

9. Energy balance test on Diesel engine using exhaust gas calorimeter measurement method
10. Performance study on a two wheeler using chassis dynamometer
11. Performance test on vapour compression refrigeration test rig.
12. Determination of the efficiency of steam generator
13. Determination of viscosity and density of incompressible fluid
14. Determination of mass flow rate of air through an orifice meter
15. Determination of power consumption by a reciprocating compressor of refrigerator.
16. Determination of thermal conductivity of metal rod.
17. Determination of heat transfer coefficient in natural convection.

Minimum of 12 experiments are to be given

Course Designers:

- | | | |
|----|----------------|--|
| 1. | P. Maran | pmmech@tce.edu |
| 2. | B. Karthikeyan | bkmech@tce.edu |



14MT390 MANUFACTURING PROCESSES LAB	Category	L	T	P	Credit
	PC	0	0	2	1

Preamble

Manufacturing Processes lab helps to impart hands on practice of the fundamental manufacturing processes of metal casting, metal joining and metal forming. This course is also used to impart knowledge and skill in the field of machine tools used in the industries and to increase the level of confidence of students by working individually in various machine like Lathe, milling and drilling machine. This would supplement the understanding of the theory course on Manufacturing Process.

Prerequisite

- 14MT290 Workshop

Course Outcomes

On the successful completion of the course, students will be able to:

CO1	Construct the mould using single and split piece pattern and prepare for casting.	Apply
CO2	Perform Arc/MIG/Spot welding and Brazing /Soldering.	Apply
CO3	Perform various operations in lathe, milling, drilling and grinding machines.	Apply

Mapping with Programme Outcomes

COs	PO1	PO2	PO3	PO4	PO5	PO6	PO7	PO8	PO9	PO10	PO11	PO12
CO5.	S	L	L	L	L	L	L	L	L	L	L	L
CO6.	S	L	S	L	L	L	L	L	L	L	L	L
CO7.	S	S	S	L	L	L	L	L	L	L	L	L

S- Strong; M-Medium; L-Low

Syllabus**List of Exercises**

S.No	Exercises / Experiments	No of Hrs
1.	Preparation of Mould for sand casting using single piece pattern	2
2.	Preparation of Mould for sand casting using split pattern	2
3.	Practices on Casting	2
4.	Practice a butt/lap/ corner/ Tee joint using the given metal strips by ARC welding	2
5.	Practice a butt/lap/ corner/ Tee joint using the given metal strips by SPOT welding	
6.	Practice a butt/lap/ corner/ Tee joint using the given metal strips by MIG welding	2
7.	Preparation of Brazing and Soldering in the sheet metal parts like- Dust Bin/Dust Pan/ Taper Tray	2
8.	Plain, Taper and Step turning in lathe	2
9.	Grooving (UCD)and Thread (Left), and Thread (Right) in lathe	2
10.	Spur / Helical Gear Cutting in Horizontal Milling Machine	2
11.	Key Way Milling and Flat Milling in Vertical Milling Machine	2
12.	Plain Grinding, Morse Taper Grinding in Grinding Machine	2
13.	Drilling, Counter Boring and Tapping	2
	Total	24

Twelve Exercises are to be given. They have to be selected such that students would do at least one exercise in each machine

Assessment Pattern

- Students should be tested in any two exercises each 1½ hours duration.
- Students should be tested in any one exercise either in casting /welding and one exercise in machining operation in lathe/milling/drilling/grinding.

Course Designers:

1. PL. K. Palaniappan,
2. J. Umar Mohamed,

kpal@tce.edu

umar_tce_mech@tce.edu

14MT410	LINEAR ALGEBRA AND NUMERICAL	Category	L	T	P	Credit
	METHODS	BS	2	2	0	3

Preamble

This course provides fundamental knowledge of linear algebra like linear system of equations, representation of linear transformations in terms matrices, basis of a vector space, dimension and rank of vector space, orthogonalisation, inner product space and their applications in technical field.

It also provides numerical techniques to get approximate solution of required accuracy for algebraic and transcendental equations, linear simultaneous equation and ordinary differential equations.

Prerequisite

- 14MT110- Engineering Mathematics – I
- 14MT210- Engineering Mathematics

Course Outcomes

On successful completion of the course, students will be able to

CO1	Solve linear system of equations and to apply it in technical situations, and to represent linear transformations in terms of matrices also to factorise matrices.	Apply
CO2	Understand the concept of vector space, Basis, dimension and rank of vector space, null space, column space, linear transformation.	Understand
CO3	Calculate dimension, rank of a vector space, Also to apply Eigen values, Eigen vectors in linear transformation and discrete evaluation of dynamic systems.	Apply
CO4	Orthogonalise a basis and to solve system of equations $AX= b$ using least square method and to factorise matrices using singular value decomposition also to apply inner product space to evaluate weighted least square.	Apply
CO5	Solve algebraic and transcendental equations, linear simultaneous equation and ordinary differential equations, numerically.	Apply

Mapping with Programme Outcomes

Cos	PO1	PO2	PO3	PO4	PO5	PO6	PO7	PO8	PO9	PO10	PO11	PO12
CO1.	S	S	S	L	-	-	-	-	-	-	M	S
CO2.	S	S	S	L	-	-	-	-	-	-	M	S
CO3.	S	S	S	L	-	-	-	-	-	-	M	S
CO4.	S	S	S	L	-	-	-	-	-	-	M	S
CO5.	S	S	S	L	-	-	-	-	-	-	M	S

S- Strong; M-Medium; L-Low

Assessment Pattern

Bloom's Category	Continuous Assessment Tests			Terminal Examination
	1	2	3	
Remember	10	10	10	10
Understand	20	20	20	20
Apply	70	70	70	70
Analyse	-	-	-	-
Evaluate	-	-	-	-
Create	-	-	-	-

Course Level Assessment Questions

Course Outcome 1 (CO1):

- Describe and compare the solution sets of $x_1 - 2x_2 + 3x_3 = 0$, $x_1 - 2x_2 + 3x_3 = 4$.
- If v_1, v_2, v_3 and v_4 are linearly independent vectors in R^4 then show that $\{v_1, v_2, v_3\}$ is also a linearly independent.
- Show that the transformation T defined by $T(x_1, x_2) = (2x_1 - 3x_2, x_1 + 4, 5x_2)$ is not linear.

- Find an LU factorization of $A = \begin{bmatrix} 2 & -4 & -2 & 3 \\ 6 & -9 & -5 & 8 \\ 2 & -7 & -3 & 9 \\ 4 & -2 & -2 & -1 \\ -6 & 3 & 3 & 4 \end{bmatrix}$.

Course Outcome 2 (CO2):

- Given v_1 and v_2 in a vector space V, let $H = \text{Span}\{v_1, v_2\}$. Show that H is a subspace of V.
- Find a basis for the set of vectors in R^2 on the line $y=5x$.

Course Outcome 3 (CO3):

- Find the dimensions of the null space and column space of $A = \begin{bmatrix} -3 & 6 & -1 & 1 & -7 \\ 1 & -2 & 2 & 3 & 1 \\ 2 & -4 & 5 & 8 & -4 \end{bmatrix}$.
- Let $T: P_2 \rightarrow P_3$ be the transformation that maps a polynomial $p(t)$ into the polynomial $(t+5)p(t)$. Show that T is a linear transformation and find the matrix for T relative to the basis $\{1, t, t^2\}$ and $\{1, t, t^2, t^3\}$.

Course Outcome 4 (CO4):

1. Find a QR factorization of $A = \begin{bmatrix} 1 & 0 & 0 \\ -1 & 1 & 0 \\ -1 & 1 & 1 \end{bmatrix}$.

2. Find orthonormal basis of the subspace spanned by the vectors $\begin{bmatrix} 2 \\ -5 \\ 1 \end{bmatrix}, \begin{bmatrix} 4 \\ -1 \\ 2 \end{bmatrix}$.

3. Find a least square solution of $Ax = b$ for $A = \begin{bmatrix} 1 & -6 \\ -1 & -2 \\ 1 & 1 \\ -1 & 7 \end{bmatrix}, b = \begin{bmatrix} -1 \\ 2 \\ 1 \\ 6 \end{bmatrix}$.

4. Find the singular value decomposition of $A = \begin{bmatrix} 3 & 2 & 2 \\ 2 & 3 & -2 \end{bmatrix}$.

Course Outcome 5 (CO5):

- Find a root of the equation $x^3 - 4x - 9 = 0$ using bisection method in four stages.
- Apply Gauss elimination method to solve the equations $x + 4y - z = -5, x + y - 6z = -12, 3x - y - z = 4$.
- Using Runge Kutta method of order four, solve $y'' = y + xy', y(0) = 1, y'(0) = 0$ to find $y(0.2)$ and $y'(0.2)$.
- Solve the equations $10x_1 - 2x_2 - x_3 - x_4 = 3, -2x_1 + 10x_2 - x_3 - x_4 = 15, -x_1 - x_2 + 10x_3 - 2x_4 = 27, -x_1 - x_2 - 2x_3 + 10x_4 = -9$ by Gauss - Seidal iteration method.

Concept Map

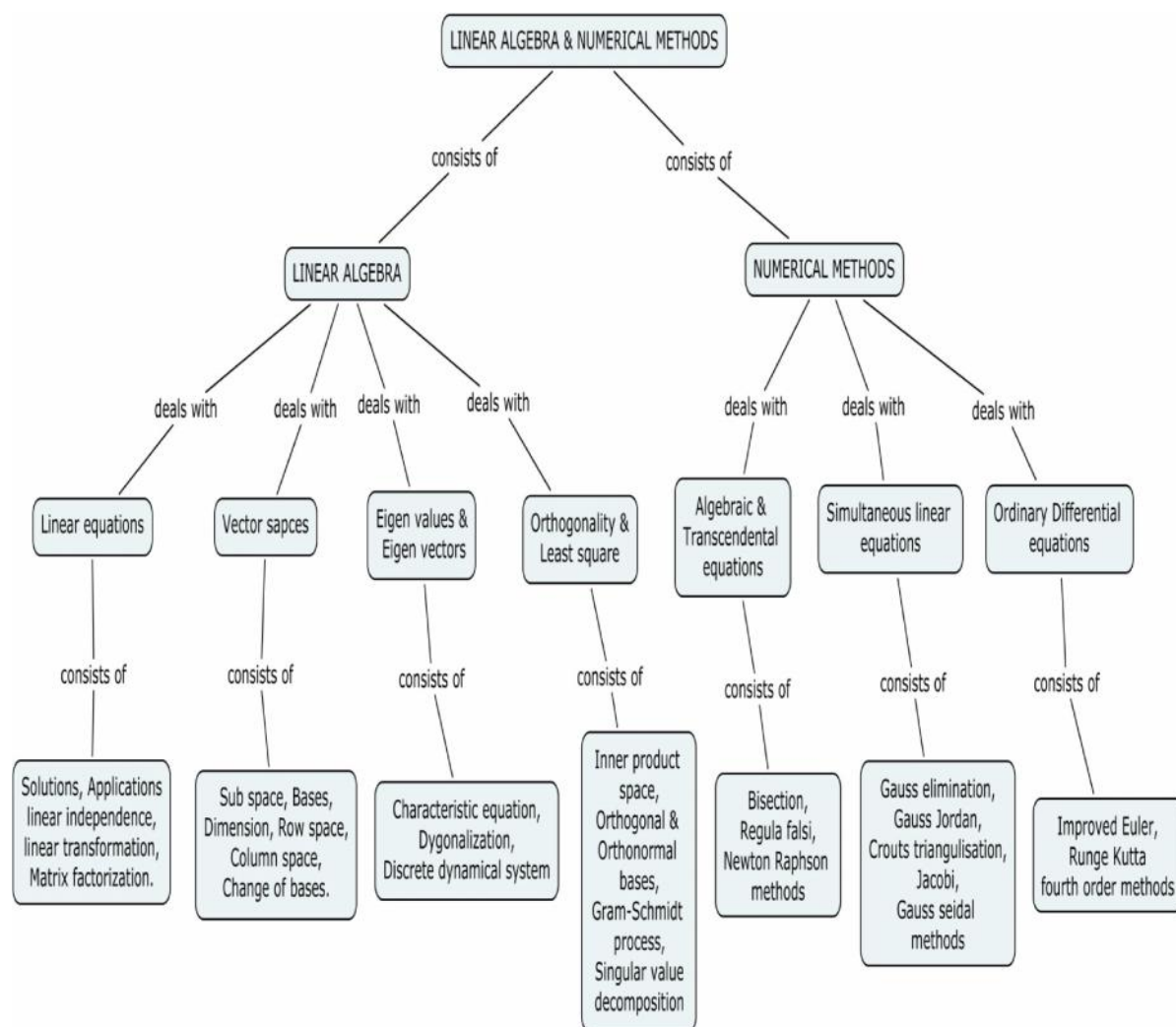

Syllabus:

Linear equations in Linear algebra: Solutions sets of linear systems – Applications of linear systems – Linear independence – Introduction to linear transformations – The Matrix of linear transformation – Matrix factorizations.

Vector spaces: Vector spaces and subspaces – Null space – column spaces and linear transformations – linearly independent sets – Bases – Coordinate systems – The Dimension of vector space – Rank – Change of basis.

Eigen values and Eigen vectors: Eigen values and Eigen vectors – The characteristic equation – Diagonalization – Eigen vectors and linear transformations – Discrete dynamical systems.

Orthogonality and least squares: Inner product – length and orthogonality – Orthogonal sets – Orthogonal projections – The Gram-Schmidt process – Least square problems – Applications to linear models – Inner product spaces – Applications to inner product spaces – The singular value decompositions – Applications to image processing and statistics.

Solutions of algebraic and transcendental equations: Bisections method – Regular falsi method – Newton Raphson method.

Solution of linear simultaneous equation: Direct methods - Gauss elimination method – Gauss Jordan method – Crout’s triangulation method. Iterative methods – Jacobi method – Gauss seidal method.

Solution of ordinary differential equations: Improved Euler’s method – Runge Kutta method of order four.

Numerical integration: Simpsons one third rule.

Text Book

1. David C. Lay, “Linear algebra and its applications”, Fourth Edition, Pearson education, 2012.
2. Grewal. B.S, “Higher Engineering Mathematics”, 41st Edition, Khanna Publications, Delhi, 2011.

Reference Books

1. Erwin Kreyszig, “Advanced Engineering Mathematics”, 8th Edition, John Wiley & Sons, 2009.
2. Steven J. Leon, “Linear algebra with applications”, 8th Edition, Pearson education, 2010.
3. Gilbert Strang, “Linear algebra and its applications”, Fourth Edition, Wellesley Cambridge Press, 2009.

Course Contents and Lecture Schedule

Module No.	Topic	No. of Lectures
1	Linear equations in Linear algebra	
1.1	Solutions sets of linear systems, Applications of linear systems	1
1.2	Tutorial	1
1.3	Linear independence, Introduction to linear transformations	1
1.4	Tutorial	1
1.5	The Matrix of linear transformation, Matrix factorizations	1
1.6	Tutorial	1
2	Vector spaces	
2.1	Vector spaces and subspaces, Null space	1
2.2	Tutorial	1
2.3	column spaces and linear transformations, linearly independent sets	1
2.4	Tutorial	1
2.5	Bases, Coordinate systems	1
2.6	Tutorial	1
2.7	The Dimension of vector space, Rank, Change of basis	1
2.8	Tutorial	1
3	Eigen values and Eigen vectors	
3.1	Eigen values and Eigen vectors, The characteristic equation	1
3.2	Tutorial	1
3.3	Diagonalization, Eigen vectors and Linear transformations	1
3.4	Tutorial	1
3.5	Discrete dynamical systems	1
3.6	Tutorial	1
4	Orthogonality and least squares	

4.1	Inner product, length and orthogonality	1
4.2	Tutorial	1
4.3	Orthogonal sets, Orthogonal projections	1
4.4	Tutorial	1
4.5	The Gram-Schmidt process, Least square problems	1
4.6	Tutorial	1
4.7	Applications to linear models, Inner product spaces	1
4.8	Tutorial	1
4.9	Applications to inner product spaces, The singular value decompositions	1
4.10	Tutorial	1
4.11	Applications to image processing and statistics	1
4.12	Tutorial	1
5	Solutions of algebraic and transcendental equations	
5.1	Bisections method, Regular falsi method	2
5.2	Tutorial	1
5.3	Newton Raphson method	1
5.4	Tutorial	1
6	Solution of linear simultaneous equation	
6.1	Direct methods - Gauss elimination method, Gauss Jordan method	2
6.2	Tutorial	1
6.3	Crout's triangulation method, Iterative methods – Jacobi method	2
6.4	Tutorial	1
6.5	Gauss seidal method	1
6.6	Tutorial	1
7	Solution of ordinary differential equations, Numerical integration	
7.1	Improved Euler's method, Runge Kutta method of order four, Simpsons one third rule.	2
7.2	Tutorial	1
	Total	48

Course Designers:

Dr. C.S. Senthil kumar
Dr. R. Suresh

-
-

kumarstays@tce.edu
suresh080183@tce.edu

14MT420**ENGINEERING DESIGN**

Category	L	T	P	Credit
PC	1	0	2	3

Common for B.E./B.Tech Degree Programmes
(Course Codes: 14CE450, 14ME420, 14EE450, 14EC450, 14IT450, 14CS340, 14MT420)

Preamble

Engineering design is normally taught, not as a unified course in India. The courses like Product design, Machine design, Electrical machine design and transformer design, Control system design and Communication system design are tailored to specific topics. There were many new approaches developed over a period of time. There is a need to discuss a unified approach of design in a course.

Prerequisite

- None

Course Outcomes

On the successful completion of the course, students will be able to

CO1: Explain the steps involved in Engineering Design	Understand
CO2: Explain the Engineering Design process and review designs with societal considerations.	Understand
CO3: Provide specification for customer needs/requirements, considering engineering Characteristics and quality Function Deployment.	Apply
CO4: Prepare conceptual design document.	Apply

Assessment Pattern

Bloom's Category	Continuous Assessment Tests		
	CAT 1	Review 1	Review 2
Remember	20	0	0
Understand	40	0	0
Apply	40	100	50
Analyse	0	0	50
Evaluate	0	0	0
Create	0	0	0

- Milestones:
 1. Problem description (3 weeks)
 2. Framework (4 weeks)
 - i. Functional requirements
 - ii. User requirements
 - iii. Performance requirements
 - iv. Specifications
 3. Preliminary design (conceptual) (3 weeks)
 - i. Cost estimates
 4. Final design (conceptual document) (2 weeks)

Review 1 for milestones 1 & 2 and Review 2 for milestones 3 & 4

Course Level Assessment Questions**Course Outcome 1 (CO1):**

1. Define Engineering Design
2. State different activities involved in Product Engineering Life Cycle
3. List different design considerations that are required for a good design
4. Explain different types of design
5. List the characteristics of environmentally responsible design

Course Outcome 2 (CO2):

1. List different modes to collect user requirements.
2. Briefly explain the classification of different types of User requirement
3. Define Benchmarking or Reverse Engineering or Product Dissection
4. List two categories of Redesign
5. Explain different activities involved in Design process
6. Explain different steps involved in Conceptual Design process

Course Outcome 3 (CO3)

1. Write product design specifications for any of the following product - Desktop Computer or Bicycle or Pencil or Computer Table or mobile.
2. Translate customer requirements into **Engineering characteristics** of any product like mobile or computer or bicycle.

Course Outcome 4 (CO4)

1. Prepare conceptual design document for any complex engineering problem related to societal engineering under specific domain.

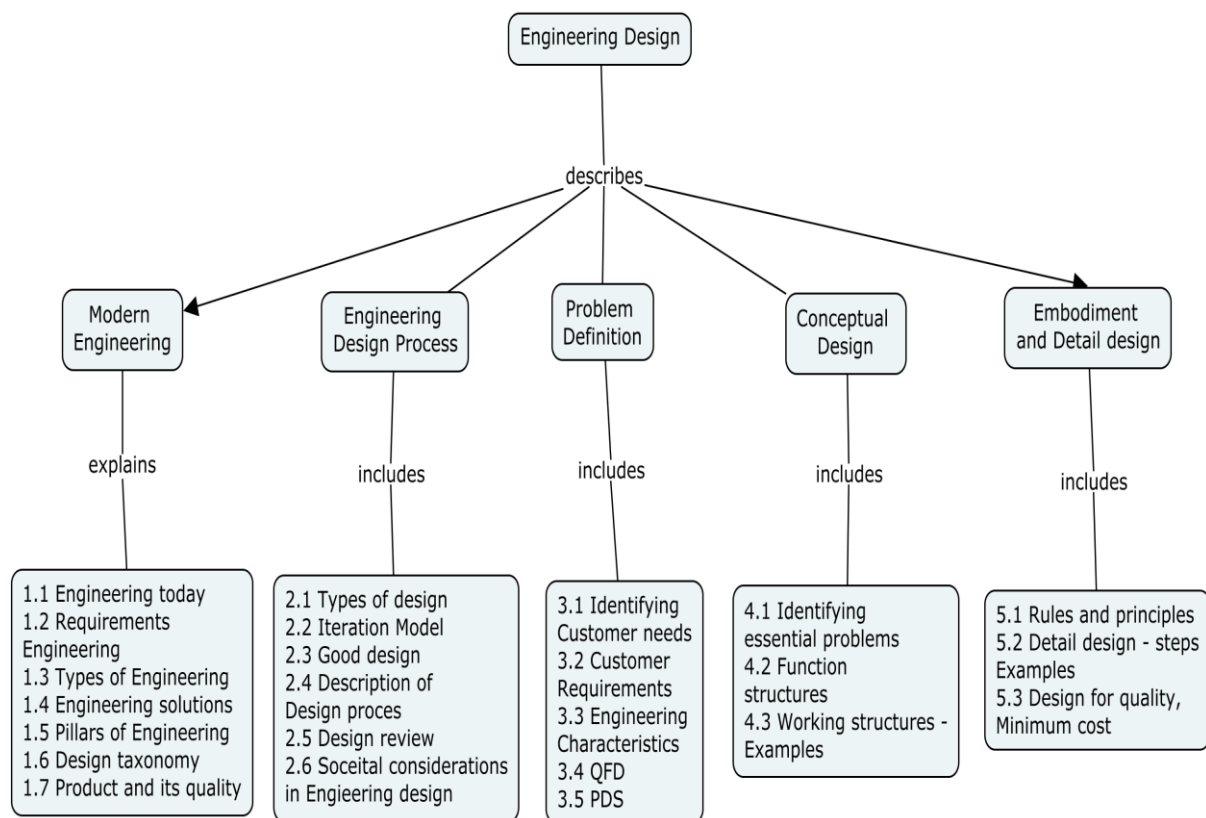
Concept Map**Syllabus**

Modern Engineering: Introduction, Engineering today, Requirements of engineering, Types of engineering, Engineering Solutions, Pillars of Engineering, Design Taxonomy, Product, Quality of product.

Engineering Design Process: Types of Designs, A Simplified Iteration Model, Considerations of a Good Design, Description of Design Process, Design Review, Societal Considerations in Engineering Design,

Problem Definition and Need Identification: Identifying Customer Needs, Customer Requirements, Establishing the Engineering Characteristics, Quality Function Deployment, product Design Specification

Conceptual Design: Steps, Abstracting to Identify the Essential Problems, Establishing Function Structures, Developing Working Structures and concepts. Examples
Embodiment and Detail Designs: Steps, Basic Rules and Principles of Embodiment Design, Detail Design, Design for Quality and minimum Cost. Examples

Reference Books

1. G.Pahl and W.Beitz (Translated by Ken Wallace et al.,) “**Engineering Design: A Systematic Approach**”, Second Edition, Springer, 2005.
2. George E. Dieter and Linda C. Schmidt, “**Engineering Design**”, Fourth Edition, McGraw Hill Higher Education, 2009.
3. Power Point Presentation material by Prof.D.K.Subramanian in the Workshop on Engineering Design at TCE, Madurai.
4. Foundation Skills in Integrated Product Development, NASSCOM, Edition 2015.

Course Contents and Lecture Schedule

Module No.	Topic	No. of Lectures
1	Modern Engineering	
1.1	Introduction - Engineering today	1
1.2	Requirements of engineering	
1.3	Types of engineering	
1.4	Engineering Solutions	1
1.5	Pillars of Engineering	
1.6	Design Taxonomy	1
1.7	Product and Quality of product	
2	Engineering Design Process	
2.1	Types of Designs	1
2.2	A Simplified Iteration Model	
2.3	Considerations of a Good Design	
2.4	Description of Design Process	1
2.5	Design Review	
2.6	Societal Considerations in Engineering Design	1
3	Problem Definition and Need Identification	
3.1	Identifying Customer Needs	1
3.2	Customer Requirements	
3.3	Establishing the Engineering Characteristics	
3.4	Quality Function Deployment	1
3.5	Product Design Specification	
4	Conceptual Design	2
4.1	Steps, Abstracting to Identify the Essential Problems	
4.2	Establishing Function Structures	
4.3	Developing Working Structures and concepts - <i>Examples</i>	
5	Embodiment and Detail Design	2
5.1	Steps, Basic Rules and Principles of Embodiment Design	
5.2	Detail Design – <i>Examples</i>	
5.3	Design for Quality and minimum Cost	
Total Lectures		12

Course Designers:

1. Dr.S.J.Thiruvengadam sitece@tce.edu
2. Dr.S.Baskar sbeee@tce.edu

14MT430**ANALOG AND DIGITAL CIRCUITS
DESIGN**Category L T P Credit
PC 3 0 0 3**Preamble**

Many of our real time signals are analog in nature. Analog signal acquisition and processing is an important task in Mechatronics systems. Similar way many of our real time processors works on digital principle. Designing an analog and digital circuit which works as an interface between analog input and output devices, and processor is a big challenge in system integration. This course aims at designing analog and digital circuits which does the function of acquiring the input signal, converting the signal adaptable to the controller, processing the signal and producing the signal which drives the output. The knowledge of Op-amp circuits, oscillators, clock generators, signal conditioning circuits, controllers, synchronous and asynchronous circuits, counters and shift registers helps the students to design more powerful, compact and efficient integrated circuit in mechatronics systems.

Prerequisite

- 14MT270 - Analog and Digital Devices

Course Outcomes

On the successful completion of the course, students will be able to

CO1:	Design feedback circuits and applications	Apply
CO2:	Design op-amp and its applications	Apply
CO3:	Design filters and controller circuits	Apply
CO4:	Design synchronous and asynchronous sequential circuits	Apply
CO5	Design of Combinational and sequential circuits using VHDL	Apply

Mapping with Programme Outcomes

COs	PO1	PO2	PO3	PO4	PO5	PO6	PO7	PO8	PO9	PO10	PO11	PO12
C01.	S	M	M	S	M	L	--	--	--	S	M	M
CO2.	S	M	M	S	M	L	--	--	--	S	M	M
CO3.	S	M	M	S	M	L	--	--	--	S	M	M
CO4.	S	M	M	S	M	L	--	--	--	S	M	M
CO5.	S	M	M	S	M	L	--	--	--	S	M	M

S- Strong; M-Medium; L-Low

Assessment Pattern

Bloom's Category	Continuous Assessment Tests			Terminal Examination
	1	2	3	
Remember	20	20	20	20
Understand	20	20	20	20
Apply	60	60	60	60
Analyse	-	-	-	-
Evaluate	-	-	-	-
Create	-	-	-	-

Course Level Assessment Questions

CO1: Design of Feedback circuits and its applications

1. State the Barkhausen criteria for production of sustained oscillation in an oscillator?
2. Differentiate open loop gain and closed loop gain
3. Define CMRR and slew rate in an op-amp?
4. Define input offset voltage and input offset current in an op-amp.
5. The 741 IC OP-amp having the following parameters is connected as a non-inverting amplifier with $R_1=2M\Omega$, $R_f=10K\Omega$, $A=200,000$, $R_i=2M\Omega$, $R_o=75\ \Omega$, $f_0=5HZ$, supply voltage=15V and output voltage swing=13V. Compute the values of A_f , R_{if} , R_{of} , f_{f} , and V_{oot} .

CO2: Design of Op-amp and its applications

1. Why an op-amp in open loop is not used for most of the applications?
2. In a negative feedback amplifier using op-amp, if the voltage at the non-inverting terminal is 2 V, find the voltage at the inverting terminal?
3. For the non-inverting operational amplifier with input resistance 100 k ohm and feedback resistance 900 k ohm. Find the effect on output voltage due to common mode voltage when input voltage changes by 1V? Assume CMRR as 70 dB?
4. For a 566 VCO shown in the figure $V=10V$, $R_2=1.2\ kohm$ and $R_1=R_3=100\ kilo\ ohm$ with $C_1=0.001\ mF$.
 - a. Calculate the frequency of output?
 - b. Calculate the variation in f_o if V_c is varied between 7.7 V and 9.5 V?
 - c. Draw the square wave output if the modulating input is sine wave?

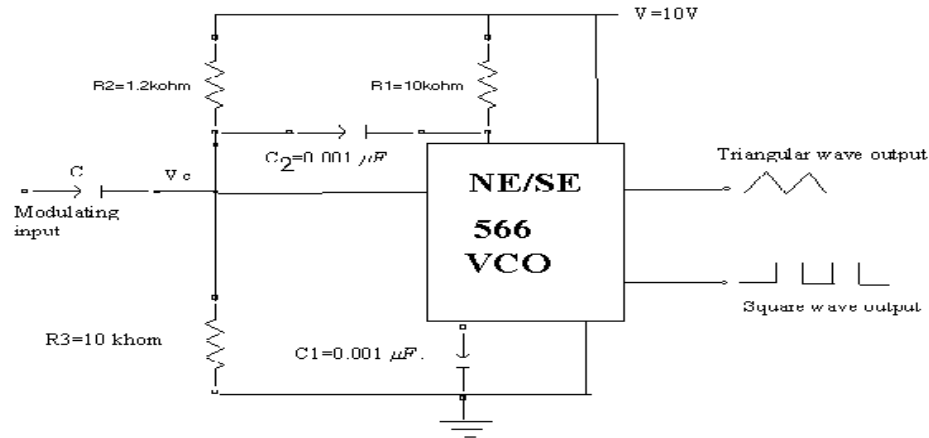

CO3: Design of filters and controller circuits

1. What is meant by active filter? Mention its advantages over passive filter?
2. Compare the frequency response characteristics of Chebyshev and Butterworth filters?
3. How does the slew rate affect the behaviour of op-amp in high frequency circuits?
4. Give the transfer function of a second-order band pass filter with centre frequency of 10^5 rad/s, a centre-frequency gain of 10, and a 3-dB bandwidth of 10^3 rad/s?
5. A PLL has the free running frequency of 500 kHz and bandwidth of the low pass filter is 10 kHz. Will the loop acquire lock for an input signal of 600 kHz? Justify your answer. Assume that the phase detector produces sum and different frequency components.

CO4: Design of synchronous and asynchronous sequential circuits

1. What is the difference between serial and parallel transfer? Explain how to convert serial data to parallel and parallel data to serial. What type of register is needed?
2. Design a four-bit shift register with parallel load using D flip-flops. There are two control inputs: shift and load. When shift = 1, the content of the register is shifted by one position. New data are transferred into the register when load = 1 and shift = 0. If both control inputs are equal to 0, the content of the register does not change.
3. Design a sequential circuit with two JK flip-flops A and B and two inputs E and F. If E = 0, the circuit remains in the same state regardless of the value of F. When E = 1 and F = 1, the circuit goes through the state transitions from 00 to 01, to 10, to 11, back to 00, and repeats. When E = 1 and F = 0, the circuit goes through the state transitions from 00 to 11, to 10, to 01, back to 00, and repeats.
4. Design a code converter that converts a decimal digit from
 - (a) The 8, 4, -2, -1 code to BCD
 - (b) The 8, 4, -2, -1 code to Gray code.

CO5: Design of Combinational and sequential circuits using VHDL

1. Develop a VHDL code for 4 bit full adder using data flow model.
2. Develop a VHDL program for 4-to-1 MUX
3. Write a complete VHDL module for 3 to 8 decoder using behavioural model.
4. Write a VHDL code for T flipflop with an active low asynchronous clear

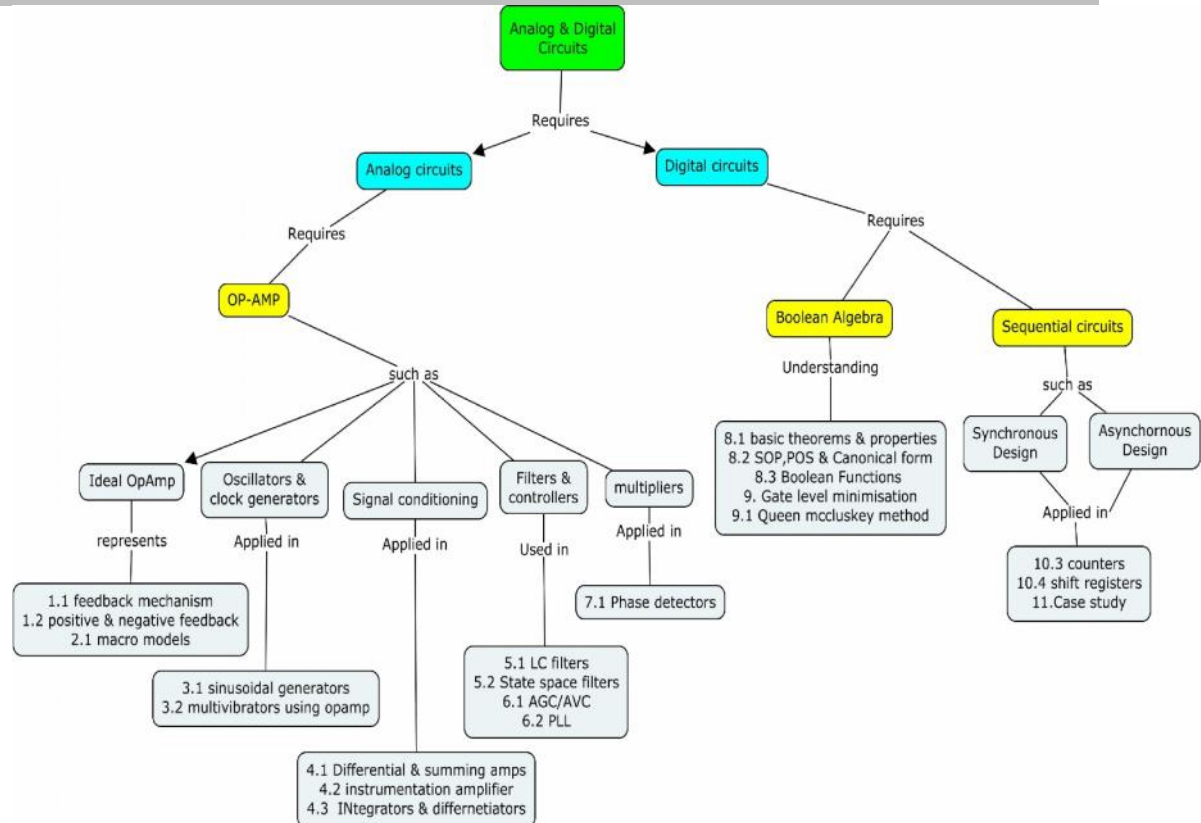
Concept Map**Syllabus**

Feedback circuits: positive and negative feedback - applications. **Op Amps:** Macro-models and -Micro-models of Op Amps and comparators. **Signal Sources and Clock Generators:** Schmitt trigger-LC/RC Oscillators-Voltage Controlled Oscillator. **Signal Conditioning and processing using Op Amps:** Differential and Summing Amplifiers-Instrumentation Amplifiers-Integrators and Differentiators. **Filters:** LC Filters **Controllers:** PID controller Design using Op-amp, AVC/AGC-Phase Locked Loops. **Multipliers:** Phase Detectors. **Combinational circuit Design-Minimization Techniques:** Karnaugh map Minimization – Don't care conditions – Quine - Mcluskley method of minimization– Tristate gates. **Sequential circuit Design:** serial adder/subtractor- Asynchronous Ripple or serial counter

– Asynchronous Up/Down counter - Synchronous counters – Synchronous Up/Down counters – Programmable counters – Design of Synchronous counters: state diagram- State table –State minimization –State assignment - Excitation table and maps-Circuit implementation - Modulo–n counter, Registers – shift registers - Universal shift registers – Shift register counters – Ring counter – Shift counters - Sequence generators.

Introduction to VHDL- capabilities, uses, packages and libraries-Programming methods-Design of combinational logic circuits-Decoder, multiplexer and demultiplexer-Design of Sequential logic circuits.

Text Books:

1. Sedra and Smith, "Microelectronic Circuits", 5th Edition, Oxford university Press, 2004
2. M.Morris Mano and Michael D clietti," Digital Design" (4th edition) Pearson Press.
3. Charles H. Roth.Jr., Fundamentals of Logic Design, Brooks/Cole CENGAGE Learning

Reference Books:

1. Handbook of operational amplifiers applications, Texas Instruments Design Reference
2. OPAMP for everyone, Ron Manchini, Editor in chief, Design Reference

Course Contents and Lecture Schedule

No.	Topic	No. of Lectures
Analog circuits		
1	Design of Op-Amp feedback circuits	
1.1	Open loop and closed loop Gain	1
1.2	Negative and positive feedback circuits	1
1.3	Application and uses –feedback	
2.	Op AMP	
2.1	Op Amps –properties, advantages	1
2.2	Macromodels &Micromodels of Op Amps	1
3.	Signal Sources and Clock Generators	
3.1	LC/RC Oscillators	2
3.2	Voltage Controlled Oscillators	1
4.	Signal Conditioning and Processing using Op Amps	
4.1	Differential and Summing Amplifiers	1
4.2	Instrumentation Amplifiers	1
4.3	Integrators and Differentiators	1
5	Filters	

5.1	LC Filters	2
6.	Controllers	
6.1	PID controller Design using Op-amp	1
6.2	AVC/AGC	1
6.3	Phase Locked Loops	1
7.	Multipliers	
7.1	Phase Detectors	1
Digital circuits		
8.	Gate level minimization	
8.1	4,5 & 6 variable K-MAP	2
8.2	Quine – Mccluskey method	
8.3	Comparator design	2
9.	Sequential Circuits	
9.1	Flip-flops and conversion	2
9.2	Synchronous and asynchronous design	2
9.3	Counters	2
9.4	Shift register	2
9.5	Sequence generators	2
10.	Introduction to VHDL	
10.1	Capabilities-uses-methods of programming – Dataflow,structural,Behavioural	2
10.2	Design of combinational circuit-Decoder,Multiplexer and demultiplexer	2
10.3	Design of sequential circuit-D flipflop,JK flipflop	2
	Total	36

Course Designers:

Mr. H. Ramesh - rameshh@tce.edu
 Mr. S. Parthasarathi - Parthasarathi_s@tce.edu

14MT440 METROLOGY AND MEASUREMENTS

Category	L	T	P	Credit
PC	3	0	0	3

Preamble

In science and engineering, objects of interest have to be characterized by measurement and testing. Measurement is an essential activity in every branch of technology and science and it is the process of experimentally obtaining quantity values that can reasonably be attributed to a property of a body or substance. Metrology is the science of measurement. The ability to measure and to compare measurements between laboratories is one of the cornerstones of the scientific method. Globalization of research, development and manufacture has produced greatly increased attention to international standards of measurement. It is no longer sufficient to achieve internal consistency in measurements within a local laboratory or manufacturing facility; measurements must now be able to be reproduced accurately anywhere in the world. In a time of constant and rapid technological development, it would be quite ambitious to develop and present a course that claimed to cover each and every industrial measuring type of equipment and its systems.

Prerequisite

- 14PH120: Physics
- 14MT330: Sensors and PLC

Course Outcomes

On the successful completion of the course, students will be able to

CO 1.	Explain the concepts and usage methods of measuring Instruments, gauges and measuring machines.	Understand
CO 2.	Choose appropriate Measuring system for the measurement of different industrial applications.	Apply
CO 3.	Select appropriate instruments/gauges to measure/inspect for different component.	Apply
CO 4.	Illustrate suitable measurement system along with its acquisition system for measuring dynamic variables in different industrial application.	Apply

Mapping with Programme Outcomes

COs	PO1	PO2	PO3	PO4	PO5	PO6	PO7	PO8	PO9	PO10	PO11	PO12
CO1.	S	M	-	-	-	-	-	-	-	-	-	-
CO2.	S	M	-	-	M	L	-	-	-	-	-	L
CO3.	S	M	M	-	-	L	-	-	-	-	-	-
CO4.	S	M	-	S	M	L	-	-	-	-	-	M

S- Strong; M-Medium; L-Low

Assessment Pattern

Bloom's Category	Continuous Assessment Tests			Terminal Examination
	1	2	3	
Remember	20	20	20	20
Understand	40	40	40	40
Apply	40	40	40	40
Analyse	0	0	0	0
Evaluate	0	0	0	0
Create	0	0	0	0

Course Level Assessment Questions**Course Outcome 1 (CO1):**

1. List out the difference between Accuracy and Precision with suitable examples.
2. Define Plunger's dial with neat diagram.
3. Discuss in detail about different methods of straightness measurement.
4. Explain a diaphragm pressure transducer working on capacitance principle with neat sketch.

Course Outcome 2 (CO2):

1. Select the suitable instrument for measuring acceleration by inductance principle, in construction application where vibration measurement at higher frequencies and also explain the working of the instruments in detail with suitable sketches.
2. Select a suitable instrument for measuring temperature in 11MW power plant furnace and also explain the working of the instruments in detail with neat sketches.
3. Select suitable instruments for measuring a) diameter of a hole up to 50 mm and b) diameter of hole less than 5 mm and also explain the working of the instruments in detail with suitable sketches.

Course Outcome 3 (CO3):

1. A cantilever beam made of spring steel (Young's modulus 200 GPa) 25 mm long has a width of 2 mm and thickness of 0.8 mm. Determine the spring constant. If all the lengths are subject to measurement uncertainties of 0.5% determine the percent uncertainty in the estimated spring constant. What is the force if the deflection of the free end of the cantilever beam under a force acting there is 3 mm? What is the uncertainty in the estimated force if the deflection itself is measured with an uncertainty of 0.5%.
2. A thermocouple has a linear sensitivity of $30\mu\text{V}/^\circ\text{C}$, calibrated at a cold junction temperature of 0°C . It is used to measure an unknown temperature with the cold junction temperature of 30°C . Find the actual hot junction temperature if the emf generated is 3.0 mv.
3. Design and sketch a working gauge with a GO and NO-GO ends for spindle $\frac{80.009}{80.000}$ mm and a hole of $\frac{79.866}{79.786}$ mm.
4. An seismic accelerometer sense displacement has an undamped frequency of 20Hz and a damping ratio 0.7. Calculate (a) damped frequency (b) the amplitude ratio and phase angle between the motion of the seismic mass and the applied vibration if the later is a sinusoidal displacement at the frequency of (i) 30Hz and (ii) 1 KHz.

Course Outcome 4 (CO4):

1. Select the suitable measurement system for measuring and recording the speed and acceleration in automobile applications. Also explain the working of the instruments and data acquisition system in detail with suitable sketches.
2. Select the suitable system for monitoring, recording the temperature in Thermal power plant furnace. Also explain the working of the instruments and data acquisition system in detail with suitable sketches.

Concept Map

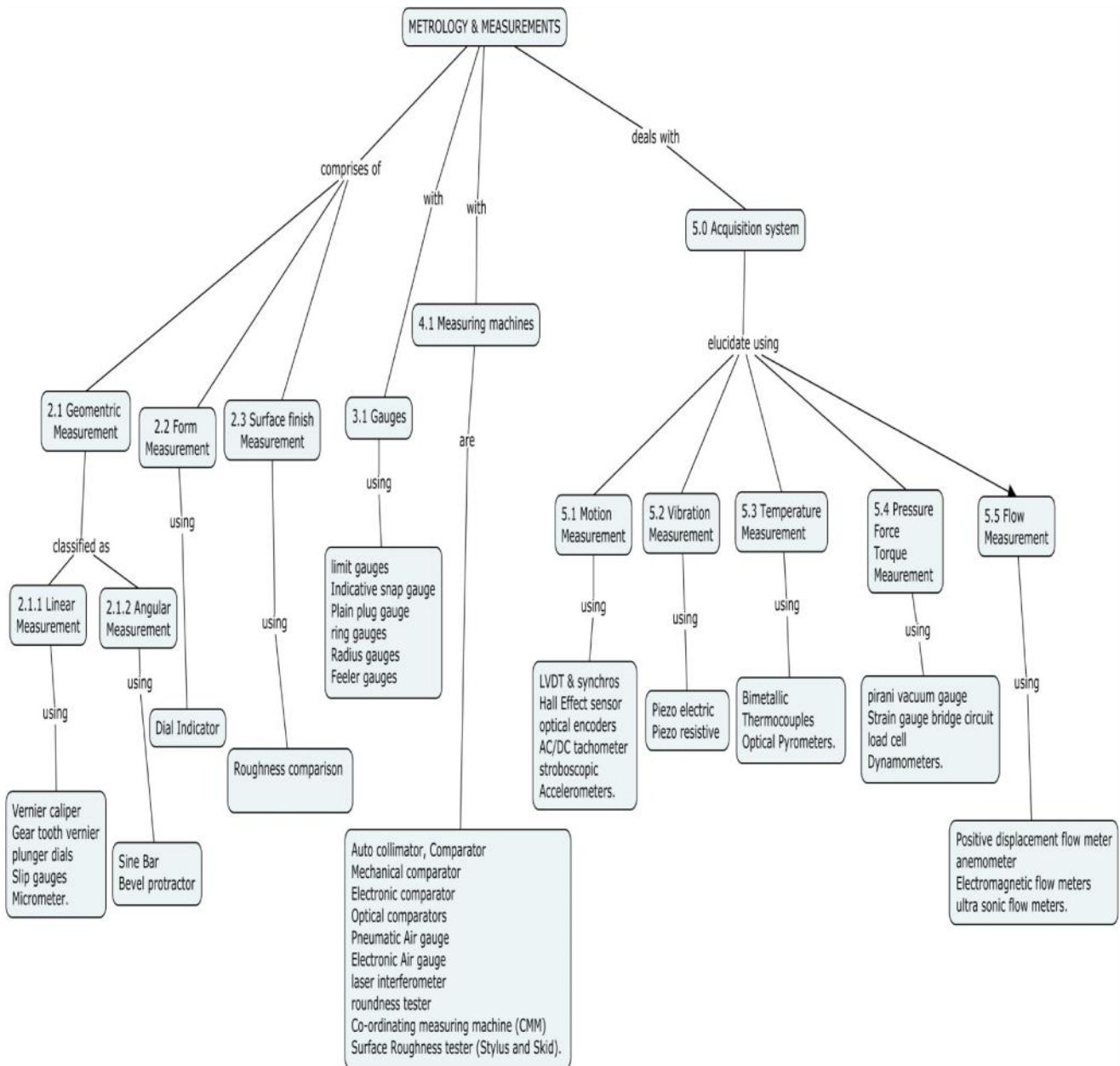

Syllabus

Introduction: Methods of measurement- significance, generalized measuring system.

Linear Measurement: Vernier calliper, Gear tooth vernier, plunger dials, Slip gauges, Inside/ Outside Micrometer.

Angular Measurement: Sine Bar, Bevel protractor.

Form Measurement: Dial indicators, Measurement of major diameter, minor diameter, flank angle, pitch and effective diameter of screw thread.

Surface finish Measurement: Surface Roughness, Symbols, Roughness comparison as per specimen, Ra, Rz, Rq, Rt, Rp, Rv - Principle and operation of stylus probe instruments. Inspection using gauges: Types- limit gauges, Indicative snap gauge, Plain plug gauge, ring gauges, Radius gauges, and Feeler gauges - Gauge design.

Measuring Machines: Auto collimator, Comparator - Mechanical comparator, Electronic comparator, Optical comparators, Pneumatic Air gauge, Electronic Air gauge, laser interferometer, roundness tester, Co-ordinating measuring machine (CMM), Surface Roughness tester (Stylus and Skid).

Data Acquisition system: Introduction, Types - Analog and digital acquisition system, different transducer and its data acquisition system for different industrial application.

Motion measurement system: LVDT & synchros based telemetering system, Hall Effect sensor, Speed measurement using optical encoders, AC/DC tachometer with PMMC voltmeter measurement system, stroboscopic, Types of Accelerometers.

Vibration measurement system: Piezo electric and Piezo resistive transducer and its applications.

Pressure, Force & Torque measurement system: Low pressure measurement by pirani vacuum gauge, Strain gauge bridge circuit, load cell circuitry for dynamic measurement and recording, Dynamometers.

Temperature measurement system: Bimetallic & Thermocouples, Optical Pyrometers.

Flow measurement system: Positive displacement flow meter, anemometer, Electromagnetic flow meters, ultra sonic flow meters.

Text Books

1. Anand K Bewoor and Vinay A Kulkarni "Metrology and Measurement" Tata McGraw Hill Edition, 2009.
2. A.K.Sawhney "A course in electrical and electronic measurements and instrumentation" Dhanpat rai and co (p) ltd seventeenth edition, 2002.

Reference Books

1. Ernest O Doebelin "Measurement Systems Application and Design" Tata McGraw Hill Edition, 2004.
2. Thomas G. Beckwith, Roy D. Marangoni, John H. Lienhard V "Mechanical Measurements" Prentice Hall, 6th Edition, 2007.
3. Sabrie Solomon, "Sensors and control systems in manufacturing", McGraw Hill international Editions, 1994.
4. Galyer.J.F.W. Shotbolt, C.R., "Metrology for Engineers", ELBS with Casell Ltd., UK, Fifth Edition, 1990.
5. Jain, R.K, "Engineering Metrology", Khanna publishers, 2009.
6. R.K.Rajput, "Engineering Metrology and Instrumentation", Kataris & sons Publishers, 2001.
7. Singh S.K., "Industrial Instrumentation and Control", Tata McGraw Hill Edition, 2003.

Course Contents and Lecture Schedule

No	Topic	No. of Lectures
1.0	Introduction	
1.1	Methods of measurement, significance, generalized measuring system, Types.	1
2.0	Measurement of Product Specifications	
2.1	Geometric Specification – classification	1
2.1.1	Linear Measurements: Vernier caliper, Gear tooth vernier, plunger dials, Slip gauges, Inside/Outside Micrometer	2
2.1.2	Angular Measurement: Sine Bar, Bevel protractor.	2
2.2	Form Measurement: Dial indicators.	2
2.2.1	Measurement of major diameter, minor diameter, flank angle, pitch and effective diameter of screw thread.	2
2.3	Surface finish Measurement:	1
2.3.1	Surface Roughness, Symbols, Roughness comparison as per specimen, R_a , R_z , R_q , R_t , R_p , R_v	2
2.3.2	Principle and operation of stylus probe instruments	1
3.0	Gauges:	
3.1	Inspection using gauges: Types- limit gauges	1
3.1.1	Snap gauge, Plain plug gauge, ring gauges, Radius gauges, and Feeler gauges - Gauge design.	2
4.1	Measuring Machines:	
4.1.1	Auto collimator, Comparator – Mechanical, Electronic and Optical comparators,	2
4.1.2	Pneumatic Air gauge, Electronic Air gauge, laser interferometer, roundness tester	2
4.1.3	Co-ordinating measuring machine (CMM), Surface Roughness tester (Stylus and Skid)	2
5.0	Data Acquisition system:	
5.0.1	Introduction, types-Analog and digital acquisition system.	2
5.0.2	Different transducers and its data acquisition system for different industrial application.	2
5.1	Motion measurement system:	
5.1.1	LVDT & synchros based telemetering system, Hall Effect sensor	2

No	Topic	No. of Lectures
5.1.2	Speed measurement using optical encoders, AC/DC tachometer with PMMC voltmeter measurement system, stroboscopic.	2
5.1.3	Acceleration measurement using different types of accelerometer.	1
5.2	Vibration measurement system: Piezo electric and Piezo resistive transducer and its applications.	2
5.3	Pressure, Force and Torque measurement system:	
5.3.1	Low pressure measurement by pirani vacuum gauge, Dynamometers.	1
5.3.2	Strain gauge bridge circuit, load cell circuitry for dynamic measurement and recording	2
5.4	Temperature measurement system: Bimetallic & Thermocouples, Optical Pyrometers.	2
5.5	Flow measurement system: Positive displacement flow meter, anemometer.	2
5.5.1	Electromagnetic flow meters, ultra sonic flow meters.	1
TOTAL		42

Course Designers:

Mr. M. Balamurali - balacim@tce.edu
 Mr. S. Julius Fusic - sjf@tce.edu

14MT450 FLUID POWER AUTOMATION

PC 3 0 0 3

Preamble

The fluid power is used extensively in every branch of industry due to its simplicity, economy, ease and accuracy of control. Fluid power becomes important part of most vehicles in the transportation industry. In manufacturing, the application of fluid power is continuously increased the productivity of workers and thus had a direct impact on the standard of living. Also today's industry depend more on automation in order to increase productivity..Electrical control of fluid power began to enter the commercial sector with the development of servo controlled valves. The manufacturing process could be simplified by integrating fluid power systems with the automation products.

This course aims at giving adequate exposure to the function of hydraulic and pneumatic components, its selection and application in the design of hydraulic and pneumatic circuits. The knowledge of electrically controlled servo valves, design of Electrical and PLC based pneumatic and hydraulic circuits helps the students in developing a innovative mechatronics system.

Prerequisite

- 14MT270- Analog and Digital Devices

Course Outcomes

On successful completion of the course, students will be able to

CO1:	Classify the properties of pneumatic and hydraulic systems and their applications	Understand
CO2:	Classify and select the pumps and motors for the required applications.	Understand
CO3:	Design the fluid systems with speed, pressure and direction control	Apply
CO4:	Design the hydraulic and pneumatic circuits for the given application.	Apply

Mapping with Programme Outcomes

COs	PO1	PO2	PO3	PO4	PO5	PO6	PO7	PO8	PO9	PO10	PO11	PO12
CO1.	S	M	L	L	--	--	--	--	--	--	L	L
CO2.	S	M	L	L	M	--	--	--	--	--	M	M
CO3.	S	M	L	S	--	--	--	--	--	--	S	S
CO4.	S	M	L	S	--	--	--	--	--	--	S	S

S- Strong; M-Medium; L-Low

Assessment Pattern

Bloom's Category	Continuous Assessment Tests			Terminal Examination
	1	2	3	
Remember	20	20	20	20
Understand	20	20	20	20
Apply	60	60	60	60
Analyse	-	-	-	-
Evaluate	-	-	-	-
Create	-	-	-	-

Course Level Assessment Questions**CO1: Classify the properties of pneumatic and hydraulic systems and their applications**

1. Define positive displacement pump
2. Name some positive displacement pump
3. List the parameters for selection a pump
4. What are the various type of hydraulic motors?
5. What is the control required for hydraulic circuits?
6. Name some pressure control valves
7. Why flow control is essential
8. What is FRL unit

CO2: Classify and select the pumps and motors for the required applications

1. Compare the hydraulic and pneumatic
2. Distinguish between external and internal gear pump.
3. Describe the working principle cushioned cylinder
4. Distinguish between mechanical and Electro Hydraulic Servo Systems
5. Classify the pumps
6. Compare the meter-in and meter-out circuits

CO3: Design the fluid systems with speed, pressure and direction control

1. Discuss in detail the 4/3 direction control valve with example
2. Justify the use of compound relief valve
3. Analyse the need for flow control valve using an application circuit

CO4: Design the hydraulic and pneumatic circuits for the given application.

1. With neat sketch explain the working of the gear pump
2. Explain the cascade method of circuit design with example

3. Design a circuit for the A+B+A-B- using step-counter method
4. Draw the ladder diagram for A+B+C-A-B-C+ and explain its operation

Concept Map

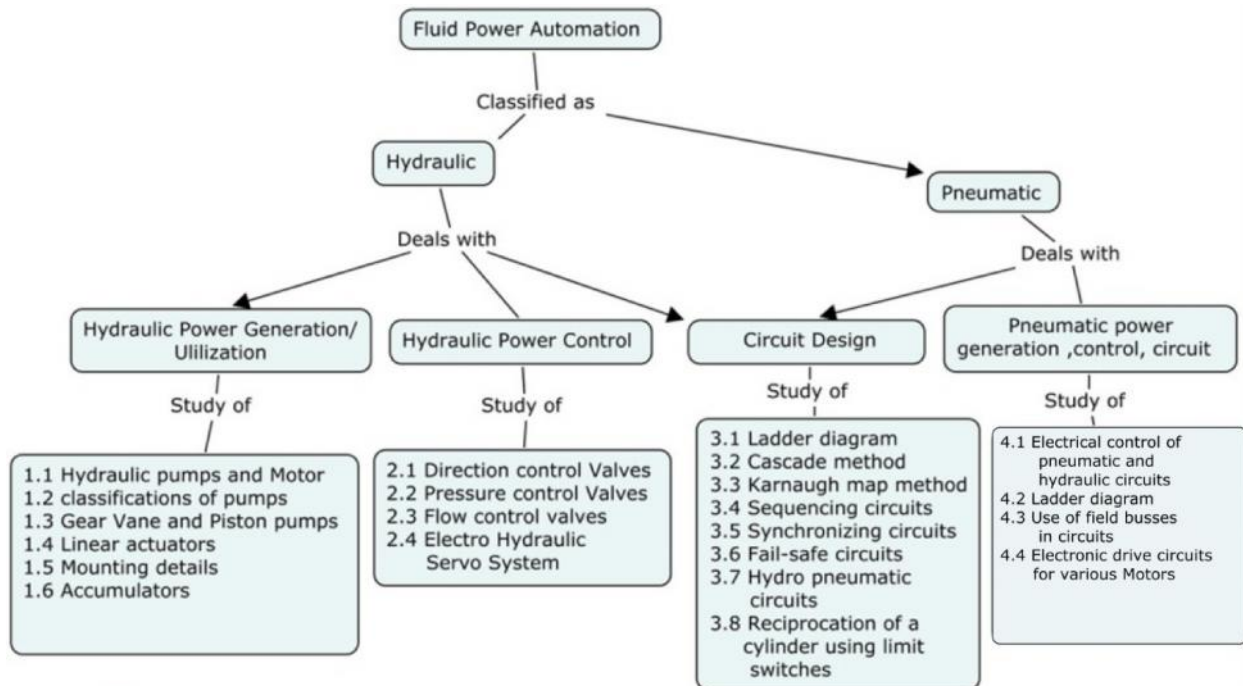

Syllabus

INTRODUCTION: Need for Automation, Hydraulic, pneumatic – Properties of hydraulic fluids – General types of fluids – Applications of Pascals Law- Properties of air Kinetic theory of gases – Boyle’ s Law - Laminar and Turbulent flow – Reynold’s number Selection criteria.

FLUID POWER GENERATING/UTILIZING ELEMENTS: Hydraulic pumps and motor gears, vane, piston pumps-motors-selection and specification- pump performance – Variable displacement pumps .Drive characteristics – Compressors – Filter, Regulator, Lubricator Unit – Air control valves -Linear actuator – Single acting, Double acting special cylinders like tanden, Rodless, Telescopic, Cushioning mechanism, Construction of double acting cylinder, Limited rotation motor, mounting details, power packs – construction. Reservoir, accumulators – standard circuit symbols.

CONTROL AND REGULATION ELEMENTS: Direction flow and pressure control valves- Directional control valve – 3/2 way valve – 4/2 way valve – 5/2 way valve . Shuttle valve – check valve. Pressure control valve – Simple and compound relief valve, pressure reducing valve, sequence valve, counter balance valve. Flow control valve Fixed and adjustable . Methods of actuation, electro hydraulic servo valves

CIRCUIT DESIGN: Design requirements-Speed control circuits, synchronizing circuit, Penumo hydraulic circuit, Fail safe circuit, Sequential circuit design for simple applications using cascade method, step counter method.

Electrical control of pneumatic and hydraulic circuits-use of relays, timers, counters, Ladder

diagram. Programmable logic control of Hydraulics Pneumatics circuits, PLC wiring diagram for various circuits –Safety considerations.

Text Book

1. Anthony Esposito ,Fluid Power with Applications, Prentice-Hall, 2009
2. Andrew Parr, Hydraulics and Pneumatics: A technician's and engineer's guide [Kindle Edition]

Reference Books

1. W.Bolton, Mechatronics, Electronic control systems in Mechanical and Electrical Engineering Pearson Education, 2011.
2. Peter Rohner, Fluid Power Logic Circuit Design, Mcmelan Prem, 1994.
3. Eaton Hydraulics Training Services (Vickers), Industrial Hydraulics Manual 5th Ed. 2nd Printing 2008
4. Frank Yeaple, Fluid Power Design Handbook, Third Edition, CRC Press
5. James L. Johnson "Introduction to Fluid Power" Delmar Thomson Learning Publishers 2003.
6. CMTI Handbook
7. James R. Daines -Fluid Power: Hydraulics and Pneumatics Second Edition, Textbook Edition,GW publisher lab manual
8. Peter croser, Frank abel, Pneumatics,Basic level ,Festo Manual, Edition 10/2002
9. Festo Hydraulics manual advanced level Edition 1999.

Course Contents and Lecture Schedule

No	Topic	No. of Lectures
1	INTRODUCTION	
1.1	Need for Automation, Hydraulic & Pneumatic basics	1
1.2	Properties of hydraulic fluids – General types of fluids – Applications of Pascals Law- Properties of air Kinetic theory of gases – Boyle's Law - Laminar and Turbulent flow – Reynold's number Selection criteria	2
2	FLUID POWER GENERATING/UTILIZING ELEMENTS	
2.1	Hydraulic pumps and Motor	2
2.2	Gear, Vane and Piston motors	1
2.3	Gear, Vane and Piston pumps	1
2.3.1	Selection and specification-Drive characteristics	1
2.3.2	pump performance – Variable displacement pumps	1
2.4	Compressors – Filter, Regulator, Lubricator Unit – Air control valves	2

2.5	Linear actuator – Single acting, Double acting special cylinders like tandem, Rod less, Telescopic, Cushioning mechanism, Construction of double acting cylinder, Limited rotation motor	2
2.6	Cylinder mounting details	1
2.7.1	power packs – construction	1
2.7.2	Reservoir , Accumulators	1
2.8	standard circuit symbols	2
3	CONTROL AND REGULATION ELEMENTS	
3.1	Direction control Valves 3/2 way valve – 4/2 way valve – 5/2 way valve. Shuttle valve – check valve	2
3.2	Flow control valves - Fixed and adjustable	2
3.3	pressure control - Simple and compound relief valve ,pressure reducing valve, sequence valve, counter balance valve	2
3.4	Methods of actuation – types	1
3.5	electro hydraulic servo valves- Different types- characteristics and performance	2
4	CIRCUIT DESIGN	
4.1	Speed control circuits	1
4.2	synchronizing circuit	1
4.3	Pneumo hydraulic circuit,Fail-safe circuit	1
4.4	Sequential circuit design for simple applications using cascade method, step counter method.	2
4.5	Electrical control of pneumatic and hydraulic circuits-use of relays, timers, counters	2
4.6	Ladder diagram. Programmable logic control of Hydraulics Pneumatics circuits	1
4.7	PLC wiring diagram for various pneumatic circuits, Safety considerations.	1
Total		36

Course Designers:

Dr. M. Elango - memech@tce.edu
 Mr.H.Ramesh - rameshh@tce.edu

14MT470 PROFESSIONAL COMMUNICATION

Category	L	T	P	Credit
HSS	1	0	2	2

Preamble

This course provides opportunities to students to develop and demonstrate basic communication skills in technical, professional and social contexts effectively.

Prerequisite

- 14EG140: English

Course Outcomes

On the successful completion of the course, students will be able to

CO 1.	Plan, organise, write, and present project reports, and technical papers in the frame of the scientific method	Apply
CO 2.	Establish themselves through communication skills in corporate environment.	
CO 3.	Solve verbal aptitude questions related to placement and higher studies.	Apply
CO 4.	Apply their interpersonal skills in technical, professional and social contexts.	Apply

Mapping with Programme Outcomes

COs	PO1	PO2	PO3	PO4	PO5	PO6	PO7	PO8	PO9	PO10	PO11	PO12
CO3.									M	M		
CO4.									M	M		
CO5.									M	M		
CO6.									M	M		

S- Strong; M-Medium; L-Low

Assessment Pattern

Internal

- **No Continuous Assessment Test (CAT) will be conducted.**

Project Report Preparation and

Technical Presentation through PPT	-	15
Listening Test	-	10
Spoken Task – Group Discussion / Mock Job Interview	-	10
Writing – Verbal Aptitude for Placement and Higher studies- (The test will be conducted for 50 marks and reduced to 15)		15

External (Practical)

Listening Test	-	20
----------------	---	----

Group Discussion	-	25
Personal Interview / Situational Conversation	-	25
Technical Presentation	-	20
Resume	-	10

Course Contents and Lecture Schedule

Sl. No.	Topic	No. of Hours	
		Theory	Practical
1	Literature Survey / Project Title Selection	1	
2	Characteristics of Technical Paper and Project Report	1	
3	Abstract / Data Presentation	1	
4	Common Errors in Technical Writing	1	
5	Bibliography and References	1	
6	Vocabulary Development	1	
7	Sentence Completion	1	
8	Error Spotting	1	
9	Interpretation of Verbal Analogy	1	
10	Interpretation of Reading (Comprehension - Conception)	1	
11	Interpretation of Reading (Comprehension - Reasoning)	1	
12	Practice for writing E-mails	1	
13	PPT Preparation /Demonstration of Technical Presentation		4
14	Preparation of Resume		2
15	Preparation for Job Interviews		4
16	Demonstration of Group Discussion Skills		4
17	Developing Listening Skill (Comprehension)		3
18	Practice for Short Speeches / Situational Conversation		4
19	Development of Employability Skills		2
20	Non-Verbal Communication		1
Total		12	24

Reference Books:

1. Courseware on “**Technical Communication for Scientists and Engineers**”, IIT Bombay, 2015.
2. Cappel, Annette and Sharp, Wendy, “**Cambridge English: Objective First**”, 4th edition., CUP, New Delhi, 2013
3. Sue Prince, Emma, “**The Advantage: The 7 soft skills you need to stay one step ahead**”, 1st edition, Pearson; 2013.

4. Cusack, Barry, "**Improve Your IELTS Listening and Speaking Skills (With CD)**" Paperback, Macmillan, 2007.
5. Bates, [Susan](#), "**TOEFL iBT Exam Paperback**", Oxford, 2012.
6. Hart, Guy Brook, "**Cambridge English Business Benchmark**", 2nd edition, CUP 2014.

Course Designers:

- | | | |
|----|--------------------------|--------------------|
| 1. | Dr. T.Sadasivan | sadasivan@tce.edu |
| 2. | Dr. S.Rajaram | sreng@tce.edu |
| 3. | Dr. A.Tamilselvi | tamilselvi@tce.edu |
| 4. | Mr. R.Vinoth | vino@tce.edu |
| 5. | Dr.R.K.Jaishree Karthiga | jai@tce.edu |



14MT480**AUTOMATION LAB**

Category	L	T	P	Credit
PC	0	0	2	1

Preamble.

Today's Industries depend more on fully automated systems in order to increase the productivity and reduce the wastage and cost in production .PLC applications are found in both the process industries and discrete manufacturing, but it is primarily associated with the latter industries to control machines, transfer lines and material handling equipment. The purpose of using PLC's, pneumatic and hydraulics circuits is to perform logic control, which deals with event-driven changes in the system and sequence control, which deals with time-driven changes in the system. Both are referred to as switching systems in the sense that they switch their output values on and off in response to changes in events or time.

This lab develops practical skills among students for controlling industrial process and machines using Pneumatic, hydraulic and PLC systems. The outcome of this course is to enable the students to design the circuit, develop the program, interface the devices and control the machines.

Prerequisite

- 14MT280 Electrical Machines Lab
- 14MT270 Analog and Digital Devices

Course Outcomes

On successful completion of the course, students will be able to

CO1	Design and Simulate Pneumatic and hydraulic circuits using software	Apply
CO2	Design and implement Pneumatic circuits using hardware	Apply
CO3	Design and implement electro pneumatic and PLC interfacing circuits	Apply
CO4	Develop PLC program for Motor control applications	Apply

Mapping with Programme Outcomes

COs	PO1	PO2	PO3	PO4	PO5	PO6	PO7	PO8	PO9	PO10	PO11	PO12
CO1.	S	S	S	S	S	L	M	M	S	S	M	S
CO2.	S	S	S	S	S	M	M	M	S	S	M	S
CO3.	S	M	S	S	S	L	M	M	S	S	S	S
CO4.	S	M	S	S	S	M	M	M	S	S	S	S

S- Strong; M-Medium; L-Low

Syllabus**List of Experiments**

S.No	Exercises / Experiments	No of Hrs
1.	Design and Simulation of hydraulic/pneumatic sequential circuits using software	2
2.	Design and simulation of Electro hydraulic/pneumatic circuits using software	2
3.	Design and implementation of sequential circuit using pneumatic components	2
4.	Design and implementation of Pneumatic sequential circuit using cascade method	2
5.	Develop a PLC program and connection scheme for DOL starting and jogging of 3- ϕ Induction motor.	2
6.	Develop a PLC program for Automatic Forward and reversal of 3- ϕ Induction motor with mutual interlock	2
7.	Develop a plc program for controlling water level in a tank.	2
8.	Develop a PLC program to the following sequence. The main machine,M1 and lubricating pump,P1 starts at the same time.When the main machine goes off,P1 runs for another 5 minute ,then go off.	2
9.	Develop a PLC program to on and off two machines consequently with a delay of 5 seconds.	2
10.	Develop a PLC program to run the conveyor only between the count of 3 to 10 from a proximity sensor.	2
11.	Develop a PLC program and connection to run 3- ϕ Induction motor for 10 second after a count of 5 from a proximity sensor.	2
12.	Design a PLC program for speed control of 3- ϕ Induction motor using analog module.	2
13.	Design a car parking system using PLC timer and counter.	2
14.	Design and implementation of pneumatic sequential circuit using PLC.	2
	Total	24
	(Out of 14 ,12 exercises are to be given)	

Minimum of 12 experiments are to be given

Course Designers:

1. Dr. M. Elango - memech@tce.edu
2. Mr. H. Ramesh - rameshh@tce.edu

**14MT490 METROLOGY AND MEASUREMENTS
LAB**

B.E. (Mechatronics) - 2014-15
Category L T P Credit
PC 0 0 2 1

Preamble

Metrology and Measurements lab helps to impart hands on practice on Metrology & measurement techniques. This course is also used to impart knowledge and skill in the field of metrology equipments and instruments used in the industries and to increase the level of confidence of students by working individually in various machine like CMM, Profile projector, Auto collimator machine. This would supplement the understanding of the theory course on Metrology and Measurements.

Prerequisite

NIL

Course Outcomes

On the successful completion of the course, students will be able to:

CO1	Measure Linear, angular, thread elements, 2D & 3D profiles, surface roughness, flatness and straightness.	Apply
CO2	Check and calibrate different dimensions for given components.	Apply
CO3	Measure and Verify displacement, force, level, torque, strain, speed temperature.	Apply

Mapping with Programme Outcomes

COs	PO1	PO2	PO3	PO4	PO5	PO6	PO7	PO8	PO9	PO10	PO11	PO12
CO1.	S	L	L	L	L	L	L	L	L	L	L	L
CO2.	S	L	S	L	L	L	L	L	L	L	L	L
CO3.	S	S	S	L	L	L	L	L	L	L	L	L

S- Strong; M-Medium; L-Low

Syllabus

S.No	Exercises / Experiments	No of Hrs
CYCLE I METROLOGY		
1.	Profile measurement of linear, angular and thread elements using Tool Makers Microscope.	2
2.	Profile measurement of linear, angular and thread elements using Profile Projector.	2
3.	Measurement of Surface Roughness using portable surface roughness tester.	2
4.	Straightness / Flatness Testing using Autocollimator.	
5.	Checking of OD and ID using comparators– Pneumatic, electronic and mechanical.	2
6.	Calibration of micrometer / vernier caliper using Standard slip gauge	2
CYCLE II MEASUREMENT AND INSTRUMENTATION		
7.	LABVIEW based Strain measurement using strain measurement trainer.	2
8.	LABVIEW based temperature measurement and data logging using thermister.	2
9.	LABVIEW based displacement measurement and data logging using LVDT.	2
10.	Speed measurement of DC servo motor using Optical encoder	2
11.	Torque measurement using torque measurement trainer.	2
12.	Force measurement using Load cell.	2
	Total	24

Assessment Pattern

- Students should be tested with one exercise in each cycle for the duration of 3 hours.

Course Designers:

Mr. M. Balamurali	-	balacim82@tce.edu
Mr. S. Julius Fusic	-	sjf@tce.edu

14MT4C1	CAPSTONE I	Category	L	T	P	Credit
		PC	0	0	4	2

Preamble

The purpose of this course is to apply the concept of mathematics, science and engineering fundamentals and an engineering specialization to solve complex engineering problems.

Syllabus

1. Mathematics:

VECTOR CALCULUS: Gradient, divergence and curl – Directional derivative – Irrotational and solenoidal vectors – Simple problems on Vector differentiation – Vector integration - Line , Surface and Volume Integrals – Green's theorem in a plane, Gauss divergence theorem and Stokes' theorem(excluding proofs) – Simple problems using the above three theorems. ANALYTIC FUNCTIONS: Functions of complex variables – Analytic functions: Necessary conditions – Cauchy - Riemann equations and sufficient conditions (excluding proofs) Properties of analytic functions – Harmonic and conjugate functions – Construction of an analytic function – Singularity-Conformal mapping: $w = z^2$, $\sin z$, e^z and bilinear transformation. LAPLACE TRANSFORM: Laplace transform –Sufficient condition for existence – Transform of elementary functions – Basic properties – Transforms of derivatives and integrals of functions -Derivatives and integrals of transforms - Transforms of unit step function impulse functions – Transform of periodic functions. Inverse Laplace transform -Statement of Convolution theorem and simple problems – Initial and final value theorems–Solution of linear ODE of second order with constant coefficients and system of ordinary differential equations using Laplace transformation Z-TRANSFORMS: Standard Z - transforms – properties of Z - transform – Convolution theorem – Convergence – Two sided Z-transform - Inverse Z-transform – Solving difference equations using Z-transforms. Fourier Series- Fourier Transform- Partial Differential Equation(PDE)- Boundary Value Problems- Eigen values and Eigen vectors.

2. PHYSICS

First and second law of thermodynamics- Carnot's engine-Temperature-Entropy diagram- Change in entropy in reversible and irreversible process- entropy of a perfect gas- application: Heat engine-refrigerator Scanning Electron Microscope-Transmission Electron Microscope, Laser and Fibre optics, Properties of Bulk Material-Thermal properties, Expansion, Heat

capacity and conductivity, Dielectric constant, Dielectric strength, Dielectric loss, Dielectric breakdown – Maxwell equations- Magnetic properties-permeability, Hysteresis, Mechanical properties-Concept of stress and strain, Elastic and plastic deformation, Creep, Hardness and tensile strength.

3. CHEMISTRY

Batteries, Electroplating and Fuels: Definition, types of cell, primary, lead acid and lithium batteries- Fuel cells- principle, types and applications. (H₂ -O₂ fuel cell), Electroless plating –PCB manufacturing- Calorific Values- Theoretical calculation - Analysis of coal- Proximate and Ultimate analysis - Environmental pollution and management: Environmental pollution from automobiles and mechanical industries – monitoring pollution- Euro norms- Bharath stage norms and ISO 14000 standards, control of pollution- carbon trading – alternate fuels -Bio fuels

4. ENGINEERING GROUP- 1

a. Free Body Mechanics

System of forces: Representation of Force, Moment and Couples-Reduction of system of forces to one force and couple. **Distributed forces:** Centroid of lines and areas-Centre of gravity of mass-Moment of inertia of areas-Mass moment of inertia. **Objects with friction:** Ladder, Wedge and Screw friction, Applications.

b. Kinematics

Velocity in Mechanisms: Slider Crank and Four Bar mechanism, Velocity diagram relative velocity method. **Acceleration in Mechanisms:** Acceleration diagram, Klein's construction for Slider Crank and Four Bar mechanism. **Force Analysis:** Static force analysis of linkages, Equivalent offset inertia force, Dynamic analysis of slider crank & bar mechanism. Piston and Crank effort, Inertia, **Torque turning moment diagrams:** Fluctuation of energy and speed, coefficient of fluctuation of energy and speed, Energy stored in a Flywheel, Dimensions of the flywheel rim. **Cams and followers:** classification of cam, follower and terminology; cam profile for constant velocity, SHM and constant acceleration and retardation for in line knife edge and roller followers. **Gears & Gear trains:** Classification, law of gearing, forms of tooth, interference, under cutting, minimum number of teeth on gear and pinion to avoid interference, contact ratio, simple, compound and Epicyclic gear trains. **Vibrations:** Types of Vibration – longitudinal, transverse and torsional vibrations- Dunkerley's method- - Critical speed of shafts - Frequency of undamped system - Viscous damping - Damped free vibration – Torsional vibrations, two rotor, three rotor and geared systems.

5. ENGINEERING GROUP- 2

a. Electrical Machines:

Electro mechanical system: Solenoid construction and working. **DC Machines:** Types - Constructional details, operation, Emf equation, Methods of excitation of D.C.generators Characteristics of series, shunt generator Principle operation of D.C. motor - Back emf and torque equation - Characteristics of series and shunt motors, Starting of D.C. motors, Speed control of D.C. motors. **Transformer:** Types, Construction, Working principle, Emf equation, Voltage regulation, CT & PT. **AC Machines:** Production of rotating magnetic field, Torque, slip characteristics - Power stages and efficiency - Principle and operation of single phase Induction motors - methods of speed control. **Special Machines:** Construction and working principle of Stepper Motor, Servo Motor, Permanent magnet DC motor, Switched reluctance motor, BLDC.

5. ENGINEERING GROUP - 3

a.Analog systems: Devices for Signal Conditioning Circuits: Signal Conditioning and processing functions-Diodes (Signal, power and photo)- BJTs – JFETs – MOSFETs - CMOS MOSFET. **Amplifiers:** Differential Amplifiers- Cascade Amplifiers-Current Mirrors. **Op Amps and Comparators:** Inverting and Non inverting function- Op Amps and comparators models of Op Amps. Digital systems: Boolean algebra, Logic Expressions and Truth Tables, Logic Minimization. **Combinational Functions:** Multiplexing and Demultiplexing, Adders and Subtractors, Synchronous Sequential Logic Functions: Moore and Melay Machines, Latches and Flip-Flops, State Diagrams, comparison of synchronous and asynchronous machines.

b.Sensors and PLC:

Physical Principles of Sensing: Potentiometers, metal and semiconductor strain gauges, Temperature sensors **Force and Strain sensors** :Piezoelectric transducers, photoelectric transducers, Hall effect sensors, strain gauge applications: Load and torque measurement.

Signal conditioning circuits: Strain gauge, Thermocouple, Thermistor and RTD.

Velocity and Acceleration: Basics of Gyroscope, Seismic instrument and accelerometers.

Inductive transducers- Transformer type, capacitive transducers, Proximity sensors. Application of inductive transducers. Digital displacement sensors, Fibre optic sensor, Semiconductor sensor and Smart sensors. Basic application of sensors and transducers.

PLC:Programmable Logic controller: PLC and its components, Principles of operation – PLC Architecture and specifications – PLC hardware components Analog & digital I/O modules , CPU & memory module – Programming devices – PLC- connecting sensors and executing devices. **PLC Programming:** Ladder diagram, Converting simple relay ladder diagram in to

PLC relay ladder diagram. PLC programming Simple instructions – Manually operated switches – Mechanically operated a Proximity switches - Latching relays, Timer instructions - On delay, Off delay, Cyclic and Retentive timers, Up /Down Counters, control instructions – Data manipulating instructions, math instructions; Applications of PLC – Simple materials handling applications, Automatic control of warehouse door, motor control, Automatic car washing machine.

Reference Books

1. Beer F.P. and Johnston Jr. E.R., **Vector Mechanics for Engineers: Statics and Dynamics**, Eighth Edition, Tata McGraw Hill, 2008.
2. Stephen J Chapman, **“Electrical machines fundamentals”** 4 th edition. Tata McGraw hill, 2005.
3. Sedra and Smith, **“Microelectronic Circuits”**, 5th Edition, Oxford university Press, 2004.
4. John Joseph Uicker, Gordon Pennock, Joseph E. Shigley, **“Theory of Machines and Mechanisms”**, Third Edition, Oxford University Press, 2010.
5. 1. John P. Bentley, **“Principles of Measurement Systems”**, 4th Edition, Pearson Education, 2005.

Assessment Pattern

(Common to B.E./B.Tech Programmes)

Test 1: Physics, Chemistry, Engineering Group – 1

Duration: 90 Minutes

(Total: 60 Marks)

Objective Type Questions : 30 (10 Questions from each group)

Fill up the blanks : 30 (10 Questions from each group)

Test 2: Mathematics, Chemistry, Engineering Group - 2, Engineering Group - 3

Duration: 90 Minutes

(Total: 60 Marks)

Objective Type Questions : 30 (10 Questions from each group)

Fill up the blanks : 30 (10 Questions from each group)

Test 3: Comprehensive (Mathematics, Physics, Chemistry, Engineering Group - 1, 2 and 3)

Duration: 90 Minutes

(Total: 60 Marks)

Objective Type Questions : 30 (5 Questions from each group)

Fill up the blanks : 30 (5 Questions from each group)

Final Mark consolidation:

Test No.	Marks Obtained	Converted to
Test 1	60 Marks (Max)	20 Marks (Max)

Test 2	60 Marks (Max)	20 Marks (Max)
Test 3	60 Marks (Max)	60 Marks (Max)
Total		100 Marks (Max)

Note: NO re-test will be conducted at any circumstances

Course Designers:

- | | |
|-------------------------|--------------------|
| 1. Dr.C.S.Senthil kumar | kumarstays@tce.edu |
| 2. Dr.V.Gayathri | vgphy@tce.edu |
| 3. Dr. V. Velkannan | velkannan@tce.edu |
| 4. Prof. S.Julius Fusic | sjf@tce.edu |
| 5. Prof.H.Ramesh | rameshh@tce.edu |



Preamble

Optimization is a scientific approach to decision making that seeks to best design and operate a system, usually under conditions requiring the allocation of scarce resources. Various techniques of optimization have been dealt on the title "Operations Research". Because of the complexity of most real-world optimization problems, it has been necessary for researchers and practitioners to reduce the complexity of the problem by either simplifying the problem or constraining it by making reasonable assumptions. In this course, the practical aspects of optimization methodology, with a major focus on the techniques and stratagems relevant to manufacturing, design and operations applications. Attention is given primarily to techniques applicable to problems in linear, integer, dynamic and non-linear programming. Besides, intelligent search heuristics are introduced to understand the concepts so as to apply them in solving large-scale problems.

Prerequisite

- 14MA110 - Engineering Mathematics-I

Course Outcomes

On the successful completion of the course, students will be able to

CO1.	Formulate mathematical models of Linear Programming (LP), Integer Programming (IP), Dynamic Programming (DP), Non-linear Programming (NLPP) problems	Apply
CO2.	Solve Linear Programming Problems (LPP) by graphical, simplex and dual-simplex methods	Apply
CO3.	Solve Integer Programming Problems (IPP) using branch and bound, and cutting plane method	Apply
CO4.	Solve deterministic Dynamic Programming Problems using tabular approach	Apply
CO5.	Solve unconstrained and constrained Non-Linear Programming Problems (NLPP) using appropriate techniques.	Apply
CO6.	Explain the concept and working of emerging intelligent search techniques such as Genetic Algorithm (GA), Ant Colony Optimization (ACO), Particle Swarm Optimization (PSO), Simulated Annealing Algorithm (SAA) and Tabu Search (TS).	Understand

Mapping with Programme Outcomes

COs	PO1	PO2	PO3	PO4	PO5	PO6	PO7	PO8	PO9	PO10	PO11	PO12
CO1.	S	S	M	M	-	-	-	-	M	-	-	S
CO2.	S	S	M	M	-	-	-	-	M	-	-	S
CO3.	S	S	M	M	-	-	-	-	M	-	-	S
CO4.	S	S	M	M	-	-	-	-	M	-	-	S
CO5.	S	S	M	M	-	-	-	-	M	-	-	S
CO6.	S	S	M	M	-	-	-	-	M	-	-	S

S- Strong; M-Medium; L-Low

Assessment Pattern

Bloom's Category	Continuous Assessment Tests			Terminal Examination
	1	2	3	
Remember	10	10	10	10
Understand	10	10	10	10
Apply	80	80	80	80
Analyse	-	-	-	-
Evaluate	-	-	-	-
Create	-	-	-	-

Course Level Assessment Questions

Course Outcome 1 (CO1):

1. A company produces two types of goods A and B that require gold and silver. Each unit of type A requires 3 grams of silver and 1 gram of gold while B requires 1 gram of silver and 2 grams of gold. The company can produce 9 grams of silver and 8 grams of gold. If each unit of type A brings a profit of Rs.40 and that of type B Rs.50, determine the number of units of each type that should be produced to maximize the profit. Formulate the LP Model and find the optimal product mix and the corresponding profit of the company.
2. A firm manufactures two products A and B on which the profits earned per unit are Rs. 3 and Rs. 4, respectively. Each product is processed on two machines M_1 and M_2 . Product A requires one minute of processing time on M_1 and two minutes on M_2 , while B requires one minute on M_1 and one minute on M_2 . Machine, M_1 is available for not more than 7 hours 30 minutes, while machine M_2 available for 10 hours during any working day. Formulate the problem as LPP to find the number of units of products A and B to be manufactured to get maximum profit.
3. A company manufacturer two types of products, P1 and P2. Each product uses lathe and milling machine. The processing time per unit of P1 on the lathe is 5 hours and on the milling machine is 4 hours. The processing time per unit of P2 on the lathe is 10 hours and on the milling machine is 4 hours. The maximum number of hours available per week on the lathe and milling machine are 60 hours and 40 hours, respectively. Also, profit per unit of selling P1 and P2 are Rs.6 and Rs.8, respectively. Formulate as integer programming model and determine the production volume of each of product such that the total profit is maximized.

Course Outcome 2 (CO2):

1. A company produces both interior and exterior paints from two raw materials, M_1 and M_2 . The following table provides the basic data of the problem:

	Tonnes of raw material per tonne of		
	Exterior Paint	Interior Paint	Maximum Daily Availability (Tonnes)
Raw Material, M_1	6	4	24
Raw Material, M_2	1	2	6
Profit per tonne (Rs.'000)	5	4	

A market survey indicates that the daily demand for interior paint cannot exceed that for exterior paint by more than 1 tonne. Also, the maximum daily demand for interior paint is 2 tonnes. The company wants to determine the optimum (best) product mix of interior and exterior paints that maximizes the total daily profit. Use simplex method to obtain the optimal solution.

2. Solve the following L.P. Problem by graphical method and also show that the given problem has multiple solutions.

$$\begin{aligned} \text{Maximize } Z &= 40x_1 + 100x_2, \\ \text{subject to } 12x_1 + 6x_2 &\leq 3000, \\ 4x_1 + 10x_2 &\leq 2000, \\ 2x_1 + 3x_2 &\leq 900, \\ x_1, x_2 &\geq 0. \end{aligned}$$

3. Solve the following LPP and determine the values of the decision variables using dual simplex method.

$$\begin{aligned} \text{Maximize } Z &= 3x_1 + 2x_2 \\ \text{Subject to constraints, } x_1 + x_2 &\geq 1 \\ x_1 + x_2 &\leq 7 \\ x_1 + 2x_2 &\leq 10 \\ x_1, x_2 &\geq 0. \end{aligned}$$

Course Outcome 3 (CO3):

1. Solve the following IPP:

$$\begin{aligned} \text{Maximize } Z &= 5x_1 + 10x_2 \\ \text{Subject to } 2x_1 + 5x_2 &\leq 10 \\ x_1 + 4x_2 &\leq 12 \\ x_1, x_2 &\geq 0 \text{ and are integers.} \end{aligned}$$

2. A manufacturer of a baby dolls makes two types of dolls : doll x and doll y. Processing of these two dolls is done on two machines, A and B. Doll x requires 2 hours on machine A and 6 hours on machine B. Doll y requires 5 hours on machine A and 5 hours also on machine B. There are 16 hours of time available on machine A and 30 hours on machine B. The profit gained on both the dolls is same as Rs.1 per doll. What should be the daily production of each of the two dolls?. Formulate and solve the L.P. Problem. If the optimal solution is not integer-valued, use the Branch and Bound method to find the optimal integer solution.

Course Outcome 4 (CO4):

1. The owner of a chain of four grocery stores has purchased six crates of fresh strawberries. The following table gives the estimated profits at each store when allocated various number of boxes:

	Stores			
	1	2	3	4
0	0	0	0	0
1	4	2	6	2
2	6	4	8	3
3	7	6	8	4
4	7	8	8	4
5	7	9	8	4
6	7	10	8	4

The owner does not want to split crates between stores, but is willing to make zero allocations. Discover the optimal allocation of six crates so as to maximize the profit.

3. An oil company has 8 units of money available for exploration of three sites. If oil is present at a site, the probability of finding it depends upon the amount allocated for exploiting the site as given in table:

	0	1	2	3	4	5	6	7	8
Site 1	0.0	0.0	0.1	0.2	0.3	0.5	0.7	0.9	1.0
Site 2	0.0	0.1	0.2	0.3	0.4	0.6	0.7	0.8	1.0
Site 3	0.0	0.1	0.1	0.2	0.3	0.5	0.8	0.9	1.0

The probability that the oil exists at sites 1, 2 and 3 is 0.4, 0.3 and 0.2, respectively. Find the optimal allocation of money using dynamic programming.

4. A company has 6 salesmen and 3 market areas A, B, and C. It is desired to determine the number of salesmen to allocate to each market area to maximize profit. The following table gives the profit from each market areas as a function of the number of salesmen allotted:

Salesmen Area	0	1	2	3	4	5	6
A	38	41	48	58	66	72	83
B	40	42	50	60	66	75	82
C	60	64	68	78	90	102	109

Use dynamic programming technique to solve the above problem.

Course Outcome 5 (CO5):

- Use Fibonacci search to: Maximize $f(x) = x^2 + \frac{54}{x}$; Subject to $0 \leq x \leq 5$ with six evaluations and its final interval of uncertainty having a length less than 0.5.
- Maximize $f(x_1, x_2) = x_1 - x_2 + 2x_1^2 + 2x_1x_2 + x_2^2$ starting from the point $X = (0, 0)$. Take $\Delta x_1 = \Delta x_2 = 0.8$. Perform four iterations using Hooke Jeeves search method.
- Solve the following Non linear Programming Problem (NLPP),
Minimize $Z = x_1^2 + x_2^2 + x_3^2$
Subject to, $4x_1 + x_2^2 + 2x_3 - 14 = 0$.
- Determine the value of x_1 & x_2 using Kuhn-Tucker's conditions
Maximize $Z = 10x_1 - x_1^2 + 10x_2 - x_2^2$
Subject to constraints, $x_1 + x_2 \leq 9$; $x_1 - x_2 \geq 6$.

Course Outcome 6 (CO6):

- Draw the flowchart for solving non-linear programming problem using Binary Genetic Algorithm and explain the step by step procedure with an illustration.
- Explain the principle of Particle Swarm Optimization (PSO) and mention its advantages and limitations over Genetic Algorithm.
- Discuss the parameters involved in Ant Colony Optimization (ACO) to solve the non-linear programming problem with constraints.

Concept Map

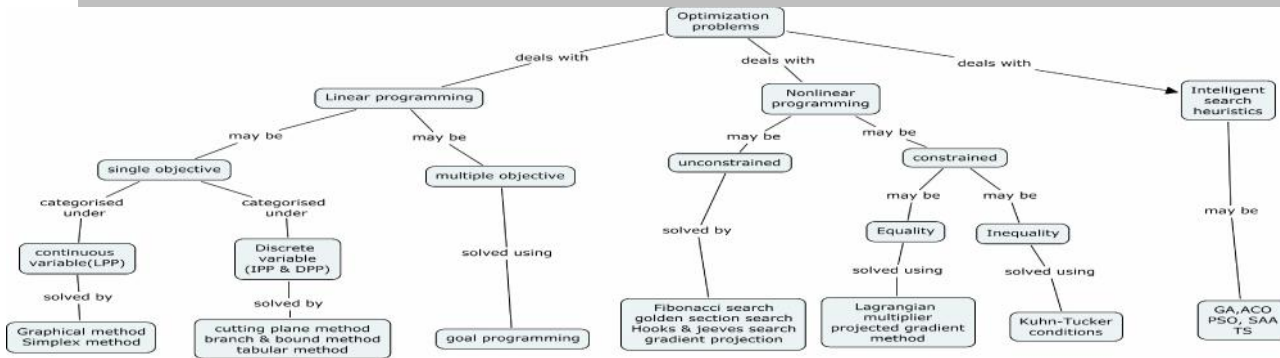

Syllabus

Linear Programming: Formulation – Graphical method and Simplex method – Dual simplex method. **Integer Programming:** Formulation – Branch and bound method – Cutting plane method. **Dynamic programming:** Concepts – Mathematical description – Deterministic dynamic programming – Tabular approach. **Goal Programming:** Concepts – Graphical solution for multiple objective problems. **Nonlinear programming (Unconstrained Problem):** Basic concepts – Fibonacci and Golden section search – Hooks and Jeeves search – gradient search. **Nonlinear programming (Equality constraints):** Lagrangian Multiplier – Equality constrained optimization – Gradient Projection methods with equality constraints. **Nonlinear programming (Inequality constraints):** Khun concept – Khun Tucker conditions. **Intelligent Search heuristics:** Concepts – Principle and parameters of GA, ACO, PSO, SAA and TS.

Text Books

1. Hamdy A. Taha, "Operations Research - An Introduction", MacMillan Co., Seventh Edition 2003.
2. Kalyanmoy Deb, "Optimization for Engineering Design – Algorithms and Examples", Eastern Economy Edition, Prentice Hall of India Private Limited, New Delhi, 1995.

Reference Books

1. S.S.Rao., "Engineering Optimization Theory & Practice", Fourth edition, John Wiley & sons publications, 2009.
2. A. Ravindran, Don. T. Phillips, and James J. Solberg, "Operations Research - Principles and Practice", John Wiley and Sons, Second Edition, Copy right 2000.
3. R. Bronson., G.Naadimuthu, "Operations Research", Second edition, Schaum series, 1997.

Course Contents and Lecture Schedule

Module No.	Topic	No. of Lectures
1	Linear Programming	
1.1	Introduction to optimization techniques & Formulation	2
1.2	Tutorial	2
1.3	Graphical methhod	1
1.4	Tutorial	1
1.5	Simplex Method	1
1.6	Tutorial	1
1.7	Dual simplex method	1
1.8	Tutorial	1
2	Integer Programming	

Module No.	Topic	No. of Lectures
2.1	Formulation	1
2.2	Tutorial	1
2.3	Branch and bound method	1
2.4	Tutorial	1
2.5	Cutting plane method	1
2.6	Tutorial	1
3	Dynamic programming	
3.1	Concepts – Mathematical description	1
3.2	Tutorial	1
3.3	Deterministic dynamic programming	1
3.4	Tutorial	1
3.5	Tabular approach	1
3.6	Tutorial	1
4	Goal Programming	
4.1	Concepts	1
4.2	Tutorial	1
4.3	Graphical solution for multiple objective problems	1
4.4	Tutorial	1
5	Nonlinear programming (Unconstrained Problem)	
5.1	Basic concepts – Fibanocci and Golden section search	1
5.2	Tutorial	1
5.3	Hooks and Jeeves search	1
5.4	Tutorial	1
5.5	gradient projection	1
5.6	Tutorial	1
6	Nonlinear programming (Equality constraints)	
6.1	Lagrangean Multiplier	1
6.2	Tutorial	1
6.3	Equality constrained optimization	1
6.4	Tutorial	1
6.5	Projected Gradient methods with equality constraints	1
6.6	Tutorial	1
7	Nonlinear programming (Inequality constraints)	
7.1	Khun concept	1
7.2	Tutorial	1
7.3	Khun Tucker conditions	1
7.4	Tutorial	1
8	Intelligent Search heuristics	
8.1	Principle and parameters of GA, ACO, PSO, SAA and TS	3
8.2	Tutorial	3
Total		48

Course Designers:

1. Dr.B. Vigneshwaran - vigneshwaran@tce.edu
2. Dr.R.Suresh - Suresh080183@tce.edu

Preamble

A Control system consists of interconnected components to achieve desired objective. It is an interconnection of components forming a system configuration that will provide a desired system response. The basis for analysis of a system is the foundation provided by linear system theory, which assumes a cause-effect relationship for the components of a system. The input-output relationship represents the cause-and-effect relationship of the process, which in turn represents a processing of the input signal to provide an output signal variable, often with a power amplification.

A closed-loop control system utilizes an additional measure of the actual output to compare the actual output with the desired output response. Time domain and frequency domain performance specifications are studied in this course. Compensator design using Lag, Lead, and Lead Lag is studied. Design of PID controller and its Digital implementation is also studied in this course. The aim of this course is to provide basic knowledge about the fundamentals of control system and digital control.

Prerequisite

- 14MT210- Engineering Mathematics-II

Course Outcomes

On successful completion of the course, students will be able to

CO 1.	Develop transfer function of a described physical system	Apply
CO 2.	System Analysis based on time and frequency domain	Apply
CO 3.	Design compensator: Lead, Lag and Lead-Lag	Apply
CO 4.	Able to calculate the stability of discrete systems	Understand
CO 5.	Implement Digital PID Controller	Apply

Mapping with Programme Outcomes

Cos	PO1	PO2	PO3	PO4	PO5	PO6	PO7	PO8	PO9	PO10	PO11
CO1.	M	S	S	M	L	-	-	-	S	-	-
CO2.	M	S	S	S	L	-	L	-	M	-	M
CO3.	L	M	S	M	M	-	-	-	M	-	-
CO4.	M	S	-	S	S	M	M	-	S	-	S
CO5.	M	S	S	S	L	-	L	-	M	-	M

S- Strong; M-Medium; L-Low

Assessment Pattern

Bloom's Category	Continuous Assessment Tests			Terminal Examination
	1	2	3	
Remember	20	20	20	20
Understand	20	40	20	40
Apply	60	40	60	40
Analyse	-	-	-	-
Evaluate	-	-	-	-
Create	-	-	-	-

Course Level Assessment Questions

Course Outcome 1 (CO1):

1. Define Transfer Function.
2. Differentiate state space and transfer function approach.
3. Determine the overall transfer function for the system shown below.

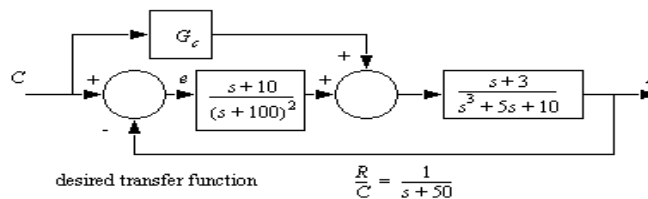

4. Develop laplace and state space model of the given 3rd order system.

$$\frac{d^3y}{dt^3} + 5\frac{d^2y}{dt^2} + 3\frac{dy}{dx} + 2y = u$$

Course Outcome 2(CO2):

1. Define Phase Margin & Gain Margin.
2. Draw root locus for the following system $G(s)=k/s^2(.5s+1)$.
3. Draw bode plot for the following system. $G(s)=100/s(.5s+1)(10s+1)$.
4. Increased track densities for computer disk drives necessitate careful design of the head positioning control. The transfer function is $G(s) = \frac{k}{(s+1)^2}$. Plot the polar plot for this system when $k=4$. Calculate the phase and magnitude at $\omega=0.5, 1, 2$.

Course Outcome 3 (CO3):

1. The feed forward transfer function is $G(s) = 4/(s(s+0.5))$. This system has closed-loop poles at $s=-0.25+j 1.9843$. The damping ratio is 0.125, the undamped natural frequency is 2 rad/sec, and the static velocity error constant is $8 s^{-1}$. It is desired to make the damping ratio of the dominant closed-loop poles equal to 0.5 and to increase the undamped natural

frequency to 5 rad/sec and the static velocity error constant to 80 s⁻¹. Design an appropriate compensator to meet all the performance specifications.

2. Create an OPAMP circuit for the given compensator equation. $G(s) = k/(0.5s + 1)$

Course Outcome 4 (CO4):

1. Explain stability in discrete control systems.
2. Explain Jury Stability.
3. How do you identify stability in a discrete control system.
4. $P(z) = z^3 - 1.3z^2 - 0.08z + 0.24 = 0$. Calculate the Jury stability.

Course Outcome 5 (CO5):

1. Explain about Ziegler Nichols tuning of PID controller.
2. Explain about advantage of implementing digital controller over analog one.
3. Write the methodology to implement PID controller.
4. Map the s domain controller $G(s) = k/s^2(0.3s + 1)$ to z domain.

Concept Map

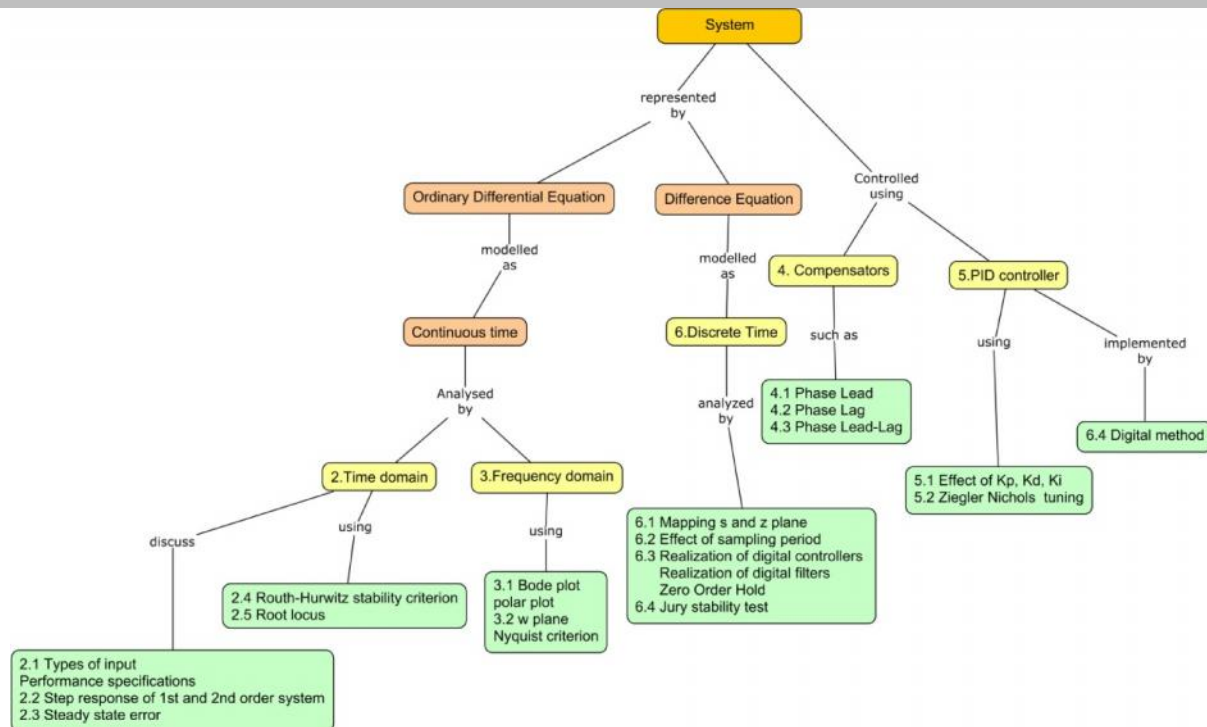

Syllabus

Introduction and Mathematial Models of system: Introduction, Examples of control system, Differential equations of physical system, linear approximation, transfer function of linear systems, block diagram reduction technique, Signal flow graph method, developing transfer function from physical system, type of the system, Introduction to MATLAB and Simulink.

Time Domain Analysis: Types of input, Performance specifications, Step response of first order and second order system, steady state error: static and dynamic error coefficients. Routh-Hurwitz stability criterion, Root locus method, Design examples,

Frequency Domain Analysis: Frequency response methods- Bode plot, polar plot, Nyquist criterion, w plane, Design Examples.

Compensator design: Phase lead, phase lag and phase lead-lag compensators, analysis using MATLAB.

PID Controller design: Effect of K_p , K_i , K_d - Ziegler Nichols Tuning.

Structure of digital control system: Mapping between s-plane and z-plane, effect of sampling period T on transient response characteristics, realization of digital controllers and digital filters, ZOH, Jury stability test– PID implementation in digital control

Text Books

1. Richard C. Dorf, Robert H. Bishop, "**Modern Control Systems**" Twelfth Edition, Pearson Education, 2014.
2. Katsuhiko Ogata, "**Control System Engineering**" second edition, Pearson Education Asia Private Ltd, 2002.
3. Katsuhiko Ogata, "**Discrete-Time Control Systems**" second edition, Pearson Education Asia, 2002.

Reference Books

1. M.Gopal, "**Control systems: Principles and Design**", Fourth edition, McGraw Hill education Private Limited, 2014.
2. Elbert Hendricks, Ole Janner up, Paul Hasse Sorenson, "**Linear systems control**" Springer. 2008.
3. Norman S Nise, "**Control Systems Engineering**", Sixth Edition, John Wiley & Sons, Inc

Course Contents and Lecture Schedule

Module No.	Topic	No. of Lectures
1	Introduction and Mathematical Models of system.	
1.1	Introduction, Examples of control system.	1
1.2	Differential equations of physical system, linear approximation.	1
1.3	Transfer function of linear systems.	2
1.4	Block diagram reduction technique.	2
1.5	Signal flow graph method.	2

Module No.	Topic	No. of Lectures
1.6	Developing transfer function from physical system	3
1.7	Introduction to Matlab and Simulink.	2
2.	Time and Frequency Domain Analysis	
2.1	Types of input, Performance specifications.	1
2.2	Step response of first order and second order system.	2
2.3	Steady state error: static and dynamic error coefficients	2
2.4	Routh-Hurwitz stability criterion.	1
2.5	Root locus method -Design examples.	3
3	Frequency Domain Analysis	
3.1	Frequency response methods: Bode plot and polar plot	2
3.2	w plane, Nyquist criterion-Design Examples.	3
4	Compensator design	
4.1	Phase lead	1
4.2	Phase lag	1
4.2	phase lead – lag, compensators analysis using MATLAB	3
5	PID Controller design	
5.1	Effect of Kp, Ki, Kd	1
5.2	Ziegler Nichols Tuning.	1
6	Structure of digital control system	
6.1	Mapping between s-plane and z-plane	1
6.2	effect of sampling period T on transient response characteristics	2
6.3	Realization of digital controllers and digital filters, ZOH	1
6.4	Jury stability test, PID implementation in digital control	1
Total Hours		31

Course Designers:

- | | | |
|---------------------|---|----------------------|
| 1. Mr T Vivek | - | tvivek@tce.edu |
| 2. Ms S. Siva Priya | - | siva2692@hotmail.com |
| 3. Mr M.A Ganesh | - | ganeshma2015@tce.edu |

Preamble

Power electronics has become a mandatory requirement for various applications. Should it be aerospace, communication, defense, marine, information technology, medical, lighting, instrumentation, entertainment everywhere. This course covers in detail the basic and advanced control techniques using power electronic converters that are used in industry. It is equally important to understand the four quadrant operation of electric drives, modulation techniques for controlling induction motors and special machines.

Prerequisite

- 14MT230 : Electrical Machines
- 14MT270: Analog and digital devices

Course Outcomes

On the successful completion of the course, students will be able to,

CO1.	Explain the operation, characteristics and performance parameters of controlled converters.	Understand
CO2.	Explain the working principle of pulse width modulated inverters.	Understand
CO3.	Select a suitable power drive for a given application.	Apply
CO4.	Choose appropriate converter technique to control electric drive for a given application.	Apply

Mapping with Programme Outcomes

COs	PO1	PO2	PO3	PO4	PO5	PO6	PO7	PO8	PO9	PO10	PO11	PO12
CO1.	S	M	-	-	-	-	-	-	-	-	-	-
CO2.	S	M	-	-	M	L	-	-	-	-	-	L
CO3.	S	M	M	-	-	L	-	-	-	-	-	-
CO4.	S	M	-	S	M	L	-	-	-	-	-	M

S- Strong; M-Medium; L-Low

Assessment Pattern

Bloom's Category	Continuous Assessment Tests			Terminal Examination
	1	2	3	
Remember	20	20	20	20
Understand	60	60	50	50
Apply	20	20	30	30
Analyse	-	-	-	-
Evaluate	-	-	-	-
Create	-	-	-	-

Course Level Assessment Questions

Course Outcome 1 (CO1):

1. List out the difference between Converter and Inverter with suitable examples.
2. Define chopper.
3. Explain the operation of three phase half wave controlled converter with inductive load. Sketch the associated waveforms.
4. With necessary circuit and waveforms, explain the principle of operation of three phase controlled bridge rectifier feeding R-L load and derive the expression for the average output dc voltage.

Course Outcome 2 (CO2):

1. Explain the effect of source inductance in the operation of three phase fully controlled converter, indicating clearly the conduction of various thyristors during one cycle with relevant waveforms.
2. Explain the effect of source inductance in the operation of single phase fully controlled converter, indicating clearly the conduction of various thyristors during one cycle.
3. Explain the working of Buck-Boost chopper with circuit diagram and characteristic waveforms.
4. Classify the various techniques adopted to vary the inverter gain and brief on sinusoidal PWM.

Course Outcome 3 (CO3):

1. Describe the working principle of boost converter with necessary circuit and waveforms.
2. Explain the operation of single phase capacitor commutated CSI with R load.
3. Draw the circuit diagram of current source inverter and explain its operation with relevant waveforms.
4. Describe the VSI fed induction motor and drives with relevant diagram.

Course Outcome 4 (CO4):

1. Select a suitable converter for separately excited dc motor drive.
2. Select a suitable inverter for operating BLDC motor in industrial application.
3. Choose an appropriate driver circuit for Solar panel angle inclination application.

Concept Map

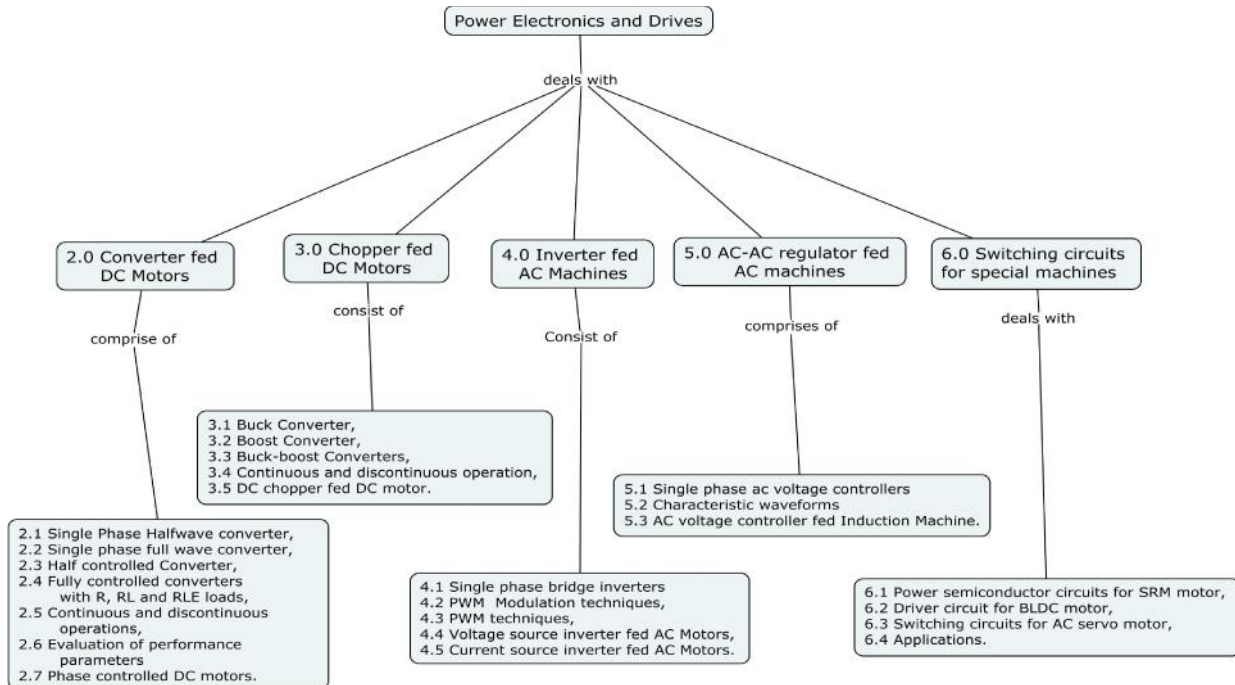

Syllabus

Introduction:

Power devices- SCR, Power MOSFET, IGBT- Electrical drive system-Types of Electric drives- selection of electrical drives- Modes of operation of electrical drives - types of power electronic converters- classification of controlled converters.

Controlled Rectifiers (Converters) DC Drives: Single Phase and three phase Half wave / full wave half controlled /fully controlled converters with R, RL and RLE loads, Continuous and discontinuous current operations- Evaluation of performance parameters –single and three Phase controlled DC drives.

Chopper Controlled DC Drives: Four Quadrant chopper- types- principle of operation of buck, boost, buck-boost Converters with continuous and discontinuous operation, DC chopper Drives, closed loop control of D.C drives-PLL, Microcomputer control.

Control of AC drives: Single phase bridge inverters with R, RL and RLE loads- Three phase inverters - PWM modulation techniques, Current source inverter.-Single and Three phase ac voltage controllers and characteristic waveforms-Induction motor drives-performance characteristics, voltage, frequency, current control, vector control, closed loop control-VFD configuration & Programming.

Switching circuits for special machines: Power semiconductor circuits for SRM motor, Driver circuit for BLDC motor, Driver circuits for AC servo motor.

Power supply: Uninterruptible power supply-UPS configurations, online & offline UPS, Line interactive UPS, Reliability of UPS System , Batteries for UPS-Capacity, efficiency, selection of battery for given specifications –SMPS-fly back ,Feed-forward, push-pull, Bridge.

Text Books

1. Mohammed H Rashid, “**Power electronics :circuit, devices and applications**” Pearson Education, fourth edition 2014.
2. P. S. Bimbhra, “**Power Electronics**“ KHANNA PUBLISHSERS-DELHI, 2012
3. R.Krishnan, “**Electrical motor drives modelling, analysis and control**” Prentice hall, 2011.

Reference Books

1. Bimal Bose, “**Power electronics and driver circuits**” Elseveir, 2010
2. Bogdan M. Wilamowski, J. David Irwin,”**Power Electronics and Motor Drives**”CRC Press ,2011
3. Bimal K Bose, “**Modern Power electronics and AC drives**” Prentice hall, 2010.

Course contents and Lecture schedule

No	Topic	No. Of Lectures
1.0	Introduction	
1.1	Power devices- SCR, Power MOSFET, IGBT	2
1.2	Electrical drive system, types of Electric drives, Selection of electrical drives, Modes of operation of electrical drives.	1
1.3	Types of power electronic converters, classification of controlled converters	1
2.0	Controlled Rectifier (Converters) DC Drives	
2.1	Single Phase and 3-phase Half wave and Full wave converter	1
2.2	Half controlled Converter	1
2.3	Fully controlled converters with R, RL and RLE loads	1
2.4	Evaluation of performance parameters	1
2.5	Single & Three phase controlled DC Drives	2
3.0	Chopper controlled DC drives	
3.1	Four quadrant chopper ,Principle of operation of buck converter	1
3.2	Boost Converter	1
3.3	Buck-boost Converters	1
3.5	DC chopper Drives.	2
3.6	Closed loop control of DC drives	1

No	Topic	No. Of Lectures
4.0	Control of AC Drives	
4.1	Single phase bridge inverters with R, RL and RLE loads	2
4.2	Three phase Inverters, PWM modulation techniques	2
4.3	Comparison among different PWM techniques	1
4.4	Current source inverter	1
4.5	Single phase and Three phase ac voltage controllers	2
4.6	Induction Motor Drives-Voltage, Frequency, Current Control	2
4.7	Vector control, closed loop control	1
4.8	VFD configuration and programming	2
5.0	Switching circuits for special machines	
5.1	Power semiconductor circuits for SRM motor	1
5.2	Driver circuit for BLDC motor	1
5.3	Driver circuit for AC servo motor	1
6.0	Power Supply	
6.1	UPS-configurations, types-online, offline, line interactive	1
6.2	Batteries for UPS, Selection for given specification	1
6.3	SMPS- Fly back , Feed-forward, Push-pull, Bridge	2
TOTAL		36

Course Designers:

1. Mr.H. Ramesh - rameshh@tce.edu
2. Mr.S.Julius Fusic - sjf@tce.edu

14MT540

CNC TECHNOLOGY

Category	L	T	P	Credit
	PC	3	0	0
				3

Preamble

This course provides fundamental knowledge about the CNC system that are predominantly found in most manufacturing industries. A CNC system is typically a traditional mechanical machine tool whose motion is controlled by electrical motors which depends on a computer program. CNC machines are capable of producing components with good accuracy and precision along with very high production rate. The dependency on the skill of the worker can be totally eliminated when CNC machines are employed.

Prerequisite

- 14MT230- Electrical Machines
- 14MT330- Sensors and PLC
- 14MT350- Manufacturing Processes

Course Outcomes

On successful completion of the course, students will be able to

CO1	Explain the evolution and importance of CNC technology in manufacturing industry.	Understand
CO2	Describe the construction features and specification of various mechanical components used in a CNC system.	Understand
CO3	Select suitable drives and sensors for a CNC system for a specific application.	Apply
CO4	Develop CNC part program for basic turning and milling operations as per product geometry.	Apply
CO5	Suggest methodologies for CNC system maintenance and troubleshooting.	Apply

Mapping with Programme Outcomes

COs	PO1	PO2	PO3	PO4	PO5	PO6	PO7	PO8	PO9	PO10	PO11	PO12
CO1	S	M	M	L	-	-	M	-	-	-	-	-
CO2	S	S	S	L	L	-	L	-	-	-	-	-
CO3	S	S	S	L	L	-	L	-	L	-	-	-
CO4	S	S	S	S	S	-	-	-	L	-	-	-
CO5	S	M	S	L	M	-	-	-	L	-	-	-

S- Strong; M-Medium; L-Low

Assessment Pattern

Bloom's Category	Continuous Assessment Tests			Terminal Examination
	1	2	3	
Remember	30	20	20	20
Understand	50	40	40	40
Apply	20	40	40	40
Analyse	-	-	-	-
Evaluate	-	-	-	-
Create	-	-	-	-

Course Level Assessment Questions

Course Outcome 1 (CO1):

1. List the vital specifications of a CNC Turning centre.
2. Explain the evolution of a CNC Machining centre.
3. Describe the safety aspects of CNC Turning and Machining centres.

Course Outcome 2 (CO2):

1. List the various types of loads acting in a CNC machine and elaborate how it influences the selection of various mechanical components.
2. Describe the ball screw and nut assembly with suitable sketches.
3. Explain the various tool monitoring system present in a CNC Turning centre.

Course Outcome 3 (CO3):

1. Design a spindle drive using VFD for varying the speed between a range of 500 to 1500 rpm for CNC Milling Machine.
2. Explain the interface between controller and Axis drive with neat block diagram.
3. Design a CNC control system using PLC and 3 Axis Servo Drive System.
4. Design a 3-axis Servo drive system for CNC Turning Machine.

Course Outcome 4 (CO4):

1. Develop part program for the given component shown in figure below that is to be manufactured in a CNC Turning centre.

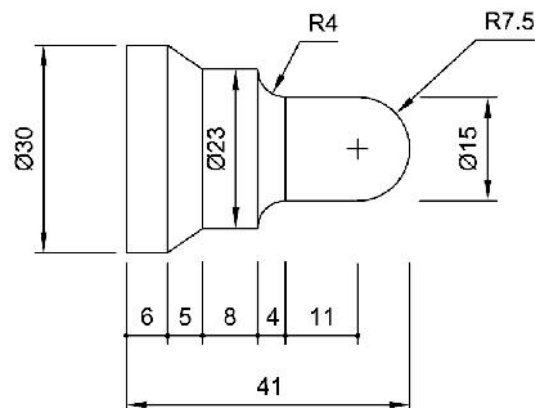

2. Develop part program for the given component shown in figure below that is to be manufactured in a CNC Machining centre.

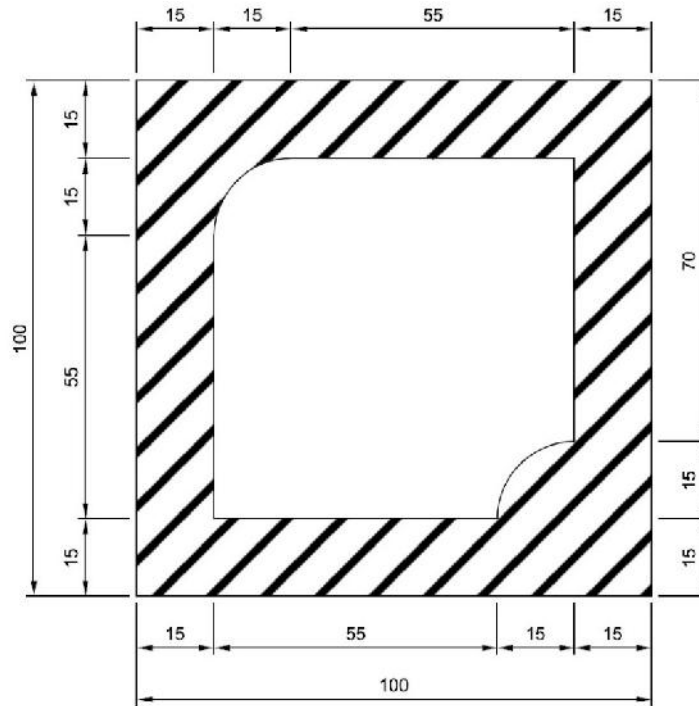

Course Outcome 5 (CO5):

1. Prepare scheduled maintenance chart for conducting maintenance activities in a CNC Turning centre.
2. Explain methods of verification to ensure the accuracy of the produced component.
3. Describe the procedure followed to verify the technical and functional specification of a CNC Machining centre.

Concept Map

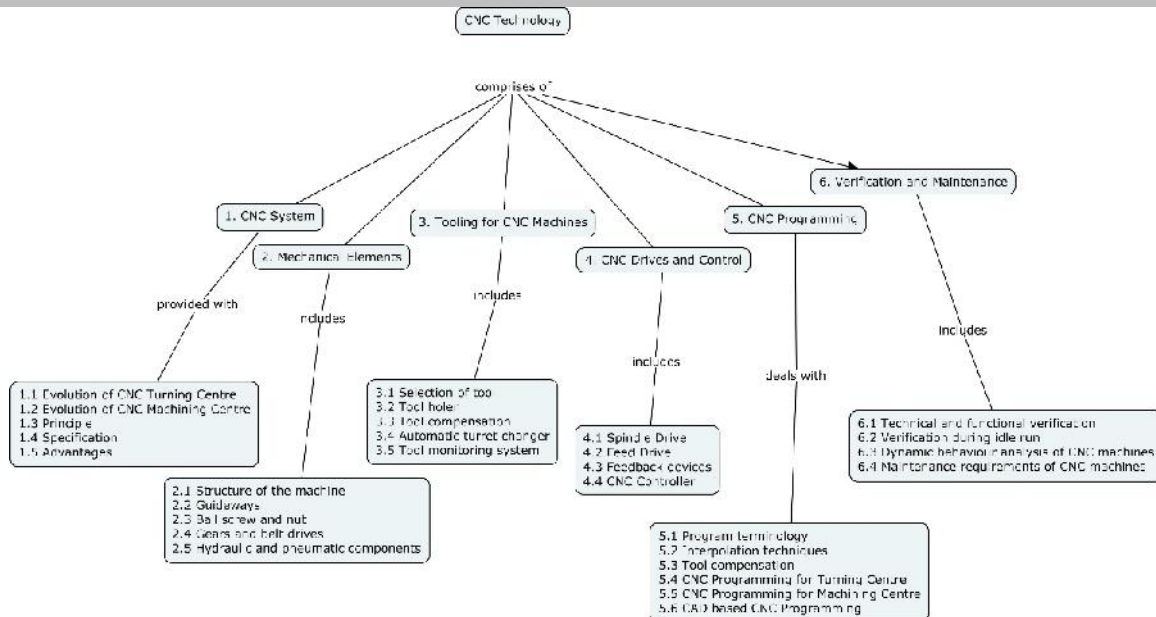

Syllabus:

Introduction to CNC Systems: Evolution of CNC Turning centre, Evolution of CNC Milling centre, Principles, specification, features, advantages and applications of CNC machines, Factors influencing the selection of CNC machines, Practical aspects of

introducing CNC machines in manufacturing industry, Retrofitting of a conventional lathe, Safety aspects of CNC machines.

Structure of CNC System: Machine physical architecture – Structural details, Types of loads on CNC machine, Types of guide ways – Friction guide ways, Antifriction guide ways, Elements for rotary motion to linear motion – Screw & nut, recirculating ball screw, recirculating ball screw, rack & pinion, Torque transmission elements – gears, timing belt, flexible coupling, bearing, Hydraulic and pneumatic systems in a CNC system.

Tooling for CNC Machines: Cutting tool materials, types of cutting tool, tool selection, tool holder, tool probing and pre-setting, tool compensation, automatic turret changer, tool monitoring system.

CNC Drives and Control: Spindle drive – Three phase induction motor – Construction, Characteristics, Speed control methods, VFD, Axis Drive – AC Servo motor, Construction, Characteristics, Closed loop position control. Feedback devices – Rotary encoder, linear scale encoder, proximity sensor, synchronous resolver. Introduction to functioning and programming of CNC Controller, PLC, Man machine interface.

CNC Part Programming: Part programming terminology – G and M codes, Types of interpolation, Types of Programming - manual part programming: fixed cycle and canned cycle for turning and milling operations, Computer Assisted Part Programming (CAPP), Introduction to CNC part programming using CAD/CAM tools.

Verification and Maintenance of CNC Machines: Verification of technical and functional aspects, Verification of CNC machine during idle running, Verification of CNC machine tool and work piece accuracy, Analysis of dynamic behaviour of CNC machine, Maintenance requirements of CNC machine – Preventive maintenance.

Text Book

1. HMT, “**Mechatronics**”, Tata McGraw-Hill Publishing Company Limited, New Delhi – 2005.

Reference Books

1. Ken Evans, “**Programming of Computer Numerically Controlled Machines**”, Industrial Press Inc. – 2007.
2. Peter Smid, “**CNC Programming Handbook**”, Industrial Press Inc. 2007.
3. Yusuf Altintas, “**Manufacturing Automation**”, Cambridge University Press, 2012.
4. G. E. Thyer, “**Computer Numerical Control of Machine Tools**”, Second Edition, B/H Newnes, 1991.
5. Graham T. Smith, “**CNC Machining Technology**”, Springer-Verlag London Limited, 1993.
6. FANUC Series 0, Maintenance Manual

Course Contents and Lecture Schedule

Module No.	Topic	No. of Lectures
1	Introduction to CNC Systems	
1.1	Evolution of CNC Turning centre, Evolution of CNC Milling centre	1
1.2	Principles, specification, features, advantages and applications of CNC machines	1
1.3	Factors influencing the selection of CNC machines, Practical aspects of introducing CNC machines in manufacturing industry	1
1.4	Retrofitting of a conventional lathe, Safety aspects of CNC machines	1
2	Structure of CNC System	

2.1	Machine physical architecture – Structural details	1
2.2	Types of loads on CNC machine	1
2.3	Types of guide ways – Friction guide ways, Antifriction guide ways	1
2.4	Elements for rotary motion to linear motion – Screw & nut, recirculating ball screw, recirculating ball screw, rack & pinion	2
2.5	Torque transmission elements – gears, timing belt, flexible coupling, bearing	1
2.6	Hydraulic and pneumatic systems in a CNC system	1
3	Tooling for CNC Machines	
3.1	Types of cutting tool, Tool selection	1
3.2	Tool holder, tool probing and pre-setting	1
3.3	Automatic turret changer, Tool monitoring system	1
4	CNC Drives and Control	
4.1	Spindle drive – Three phase induction motor – Construction, Characteristics, Speed control methods	2
4.2	VFD Axis Drive – AC Servo motor, Construction, Characteristics, Closed loop position control	2
4.3	Feedback devices – Rotary encoder, linear scale encoder, proximity sensor, synchronous resolver.	2
4.4	Introduction to functioning and programming of CNC Controller, PLC, Man machine interface.	2
5	CNC Part Programming	
5.1	Part programming terminology – G and M codes	2
5.2	Types of interpolation, manual part programming: fixed cycle and canned cycle for turning and milling operations	2
5.3	Tool compensation	1
5.4	Computer assisted part programming	2
5.5	Introduction to CNC part programming using CAD/CAM tools.	2
6	Verification and Maintenance of CNC Machines	
6.1	Verification of technical and functional aspects, Verification of CNC machine during idle running	2
6.2	Verification of CNC machine tool and work piece accuracy	1
6.3	Analysis of dynamic behaviour of CNC machine	1
6.4	Maintenance requirements of CNC machine – Preventive maintenance.	1
	Total	36

Course Designers:

Mr. H. Ramesh - rameshh@tce.edu
Mr. C. Selva Kumar - cskmech@tce.edu

Preamble

Microcontrollers based embedded systems are involved in almost every facet of modern life. Consumer gadgets, entertainments gadgets, medical devices and automobiles all contain embedded Microcontroller. The tremendous number of applications for embedded computing has given rise to high demand for engineers with experience in designing and implementing embedded systems with microcontroller. This course is designed to provide an introduction to microcontroller architecture, internal and external peripherals, assembly language programming and embedded c programming. Students will be taught the basic use of a programming environment and how to develop the basic C programming for embedded application. This course highlights the general interfacing techniques and concepts through peripheral's data representation from input/output, and memory usage in the microcontroller in embedded C.

Prerequisite

- 14MT270 - Analog and Digital Devices
- 14MT430 - Analog and Digital Circuits Design

Course Outcomes

On successful completion of the course, students will be able to

CO1.	Explain the architecture and its functional blocks of microcontroller	Understand
CO2.	Develop ASM and C program using internal and external peripherals	Apply
CO3.	Illustrate ADC,DAC and Sensor interfacing	Understand
CO4.	Design a microcontroller based system	Apply

Mapping with Programme Outcomes

COs	PO1	PO2	PO3	PO4	PO5	PO6	PO7	PO8	PO9	PO10	PO11	PO12
CO1	S	S	M	-	-	L	-	-	-	-	L	M
CO2:	S	S	M	M	-	-	-	L	-	M	L	-
CO3:	S	S	M	M	-	-	-	L	-	-	-	-
CO4:	S	S	M	-	-	L	-	-	L	-	-	M

S- Strong; M-Medium; L-Low

Assessment Pattern

Bloom's Category	Continuous Assessment Tests			Terminal Examination
	1	2	3	
Remember	20	20	20	10
Understand	40	40	40	40
Apply	40	40	40	50
Analyse	-	-	-	-
Evaluate	-	-	-	-
Create	-	-	-	-

Course Level Assessment Questions

Course Outcome 1 (CO1):

1. Distinguish between 8085 microprocessor and 8051 microcontroller.
2. List the microcontrollers in intel.
3. Define the functionality of CPU in microprocessor and microcontroller.
4. Distinguish between 8 bit and 16 bit microcontroller.
5. Define the functionality of timer peripherals in a microcontroller.
6. List the internal peripherals present in 8051.
7. Define the functionality of a serial peripheral in 8051.
8. Show that how do you access the peripherals in 8051.

Course Outcome 2(CO2):

1. Demonstrate the timer peripheral in mode 1 operation.
2. Give an example for accessing serial peripheral in polling driven.
3. Describe the use of serial peripheral in asm programming.
4. Develop a C program for a described value of time delay

Course Outcome 3 (CO3):

1. Demonstrate the timer peripherals with mode 1 and mode 2
2. Give an example for accessing timer in asm and C program
3. Describe the functionality of the GPIO hardware for accessing IO device
4. Distinguish between timer and counter in its modes of operation

Course Outcome 4 (CO4):

1. Illustrate the serials peripherals for transmitting the data in defined baud rate
2. Show the program for accessing a ADC and show it in LED display
3. Demonstrate the operation of keyboard interfacing with 8051 board
4. Construct the program for interfacing LCD module with 8051 board

Concept Map

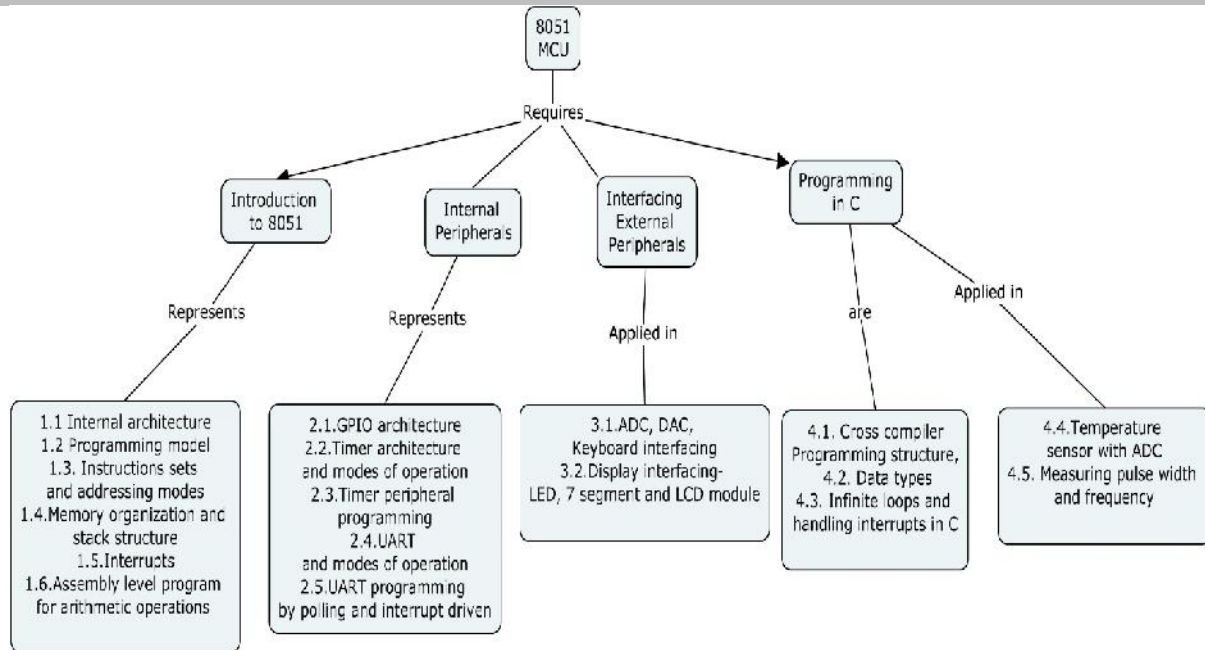

Syllabus:

Microcontrollers: 8051 Micro-controller architecture, programming model, instructions sets and addressing modes. Memory organization, stack structure and Interrupts. Assembly level program for arithmetic operations.

Internal-peripherals: GPIO architecture, Timer architecture and modes of operation, Timer peripheral programming, UART and modes of operation. UART programming by polling and interrupt driven.

External peripherals interfacing: ADC, DAC, Keyboard interfacing. Display interfacing LED 7 segment and LCD module. SPI and I2C architecture.

Programming in C: Cross compiler C -programming structure, Data types, memory models, infinite loops and handling interrupts in C. Intel Hex file format. C-Programming for LED, LCD display, temperature sensor with ADC, Measuring pulse width and frequency.

Text Book

1. Kenneth J. Ayala, "The 8051 Microcontroller. Architecture, Programming and Applns", West publishing company 2014
2. Muhammad ali mazidi, Janice Gillespie Mazidi, Rolin D.Mckinlay , "The 8051 Microcontroller and Embedded systems Using Assembly and C", Second Edition, Pearson Education,2013

Reference Books

1. MYKE PREDKO , "Programming and Customizing the 8051 Microcontroller", 1st Edition 2012
2. Chris Braith, "8051 Microcontroller application based introduction", Elsevier 2004
3. Matt Richardson, "Getting started with Intel", Galileo year 2014

Course Contents and Lecture Schedule

Module No.	Topic	No. of Lectures
1	8051 microcontrollers	
1.1	8051 Micro-controller architecture	1
1.2	Programming model	1
1.3	Instructions sets and addressing modes	3
1.4	Memory organization, stack structure	1
1.5	Interrupts	1
1.6	Assembly level program for arithmetic operations	1
	LABEx: 1 : Arithmetic operations using 8051	2
	LABEx: 2 : Sorting operations using 8051	2
2	Internal peripherals	
2.1	GPIO architecture	1
2.2	Timer architecture and modes of operation	1
2.3	Timer peripheral programming	1
2.4	UART and modes of operation	1
2.5	UART programming by polling and interrupt driven	1
	LABEx: 3 : GPIO programming using 8051	2
	LABEx: 4 : Timer programming using 8051	2
	LABEx: 5 : UART programming using 8051	2
	LABEx: 6 : Interrupt programming using 8051	2
3	External peripherals interfacing	
3.1	ADC, DAC, Keyboard interfacing	3
3.2	Display interfacing- LED, 7 segment and LCD module	2
	LABEx: 7 : 7-SEG/LCD interfacing using 8051	2

	LABEx: 8 : Matrix keyboard using 8051	2
	LABEx: 9 : ADC interfacing using 8051	2
	LABEx: 10 : DAC programming using 8051	2
4	Programming in C	
4.1	Cross compiler	1
4.2	Programming structure, Data types	1
4.3	Infinite loops and handling interrupts in C	1
4.4	Temperature sensor with ADC	1
4.5	Measuring pulse width and frequency	2
	LABEx: 11: Measuring Frequency and pulse width using 8051	2
	LABEx: 12: Design of Temperature Data logger	2

Course Designers:

1. Dr.L.R.Karlmarx lrkarlmarx@tce.edu
2. Mr.S.Parthasarathi parthasarathi_s@tce.edu

Preamble

Computer Aided Design (CAD) is the process of developing and using computer assisted design tools in the design process. Computer Aided manufacturing (CAM) is concerned with use of computer to assist with manufacturing process.

Course Outcomes

On the successful completion of the course, students will be able to

CO1:	To develop and manipulate CAD model/features for the given part /assembly drawing using operations such as extrusion, revolve, pattern hole, chamfer and rib	Apply
CO2:	To write/generate CNC part programming for given part drawing for performing operations in a CNC Lathe such as plain, stepped, thread and taper turning, and facing /Vertical milling machine such as profiling, pocketing and drilling and to simulate tool path for the machining.	Apply

Mapping with Programme Outcomes

COs	PO1	PO2	PO3	PO4	PO5	PO6	PO7	PO8	PO9	PO10	PO11	PO12
CO1.	-	-	-	M	S	-	-	-	-	M	M	-
CO2.	-	-	-	M	S	-	-	-	-	M	M	-

S- Strong; M-Medium; L-Low

Syllabus

List of Exercises (Any twelve exercises will be given)

CAD Laboratory (6 Exercises)

1. Draw the 2D Sketch of given part (2 exercise)
 - a. With out constraints.
 - b. With constraints.
2. Develop a 3D model given object (3 exercises)
 - a. Component model – Machine parts such as crank shaft, piston.
 - b. Assembly Model – Machine components such as Universal joint, Screw jack.
3. Prepare drawing layout for 3D models (1 exercise)

(2D sketch and 3D solid modelling exercises will be practised in any one of the CAD modelling packages such as Creo-Parametric (Pro/E), SolidWorks, CATIA)

CAM Laboratory (at least 6 Exercises)

1. Manual Programming for CNC Lathe (at least 2 exercises)
 - Write a manual CNC program and simulate the operation for
 - a. Plain Turning
 - b. Step turning

- c. Taper Turning
 - d. Threading
 - e. Curvature
2. Manual Programming for CNC Milling Machine (at least 2 exercises)
 - Write a manual CNC program and simulate the operation for
 - a. Profile milling
 - b. Circular and rectangular pocketing
 - c. Drilling
 3. CNC Programming using 2D drafting(at least 1 exercise)
 - Draw a 2D CAD sketch for the given part drawing and generate a CNC program the operation for
 - a. Profile milling
 - b. Circular and rectangular pocketing
 - c. Drilling
 4. Operation of CNC Milling Machine (at least 1 exercise)
 - Write a manual CNC program and perform
 - a. Profile milling
 - b. Circular and rectangular pocketing
 5. Demonstration
 - Write a robot program to execute pick and place task using multi DOF robotic manipulator
 - Demonstration of wire EDM, 3D printing, 3D scanner

Exercises will be practised in packages such as Mastercam, Fanuc and TRIAC

Course Designers:

- | | | |
|----|-------------------------|-----------------|
| 1. | Dr.S. Saravana Perumaal | sspmech@tce.edu |
| 2. | Mr.T. Prakash | tpmech@tce.edu |

Preamble.

Most of the real world and real time signals are analog in nature. Analog signal acquisition and processing is an important task in Mechatronics systems. Similar way many of our real time processors works on digital principle. Designing an analog and digital circuit which works as an interface between analog input and output devices, and processor is a big challenge in system integration.

This lab aims at designing analog and digital circuits which does the function of acquiring the input signal, converting the signal adaptable to the controller, processing the signal and producing the signal which drives the output. The knowledge of Op-amp circuits, oscillators, clock generators, signal conditioning circuits, controllers, synchronous and asynchronous circuits, counters and shift registers helps the students to design more powerful, compact and efficient integrated circuit in mechatronics systems.

Prerequisite

- 14MT270 - Analog and Digital Devices,
- 14MT430 - Analog and Digital Circuits Design

Course Outcomes

On successful completion of the course, students will be able to

CO1.	Design and implement of basic OPAMP and IC555 circuits	Apply
CO2.	Design and implement of various Analog system using Opamp	Apply
CO3.	Design and Develop combinational circuits using digital design	Apply
CO4.	Design and Develop sequential circuits using digital design	Apply

Mapping with Programme Outcomes

COs	PO1	PO2	PO3	PO4	PO5	PO6	PO7	PO8	PO9	PO10	PO11	PO12
CO1.	S	M	-	S	-	M	M	M	S	-	M	-
CO2.	S	M	S	-	S	M	M	M	-	S	M	-
CO3.	S	M	S	-	-	L	M	M	S	S	S	S
CO4.	S	M	-	S	S	M	M	M	-	-	S	S

S- Strong; M-Medium; L-Low

Syllabus**List of Experiments**

S.No	Exercises / Experiments	No of Hrs
•	Design of Inverting and Non inverting Amplifier	2
•	Design of Summing and Differential Amplifier	2
•	Design of Instrumentation amplifier	2
•	Design of Integrator and Differentiator and filter design	2
•	Design of Comparator	2
•	Design of Astable and monostable multivibrator (IC-555)	2
•	Design of waveform generator	2
•	Design of Combinational circuit with Multiplexers and Demultiplexer	2
•	Design of Combinational circuit with Encoders and Decoders	2
•	Design of Synchronous Counter	2
•	Design of Shift Registers	2
•	Design of three bit sequence detector	2
•	Implementation of second order system transfer function using OPAMP	2
•	Implementation of a case study using digital design	2
	Total	24
	(Out of 14 ,12 exercises are to be given)	

Minimum of 12 experiments are to be given

Course Designers:

- 1.Dr.L.R.Karlmarx
2. Mr.S.Parthasarathi

lrkarlmarx@tce.edu
parthasarathi_s@tce.edu

14MT610**ACCOUNTING AND FINANCE**

Category	L	T	P	Credit
PC	3	0	0	3

Preamble

Engineering profession involves lots of decision making. The decisions may range from operation to non-operation. For taking decisions of these kinds an engineer needs among other things data about the organization's routine operations and non-routine operations. Accounting is a science which provides all the data by recording, classifying, summarizing and interpreting the various transactions taking place in an organization and thereby helps an engineer in taking vital decisions in an effective manner. Finance is an allied but a separate field relying on accounting, and enables engineers in taking useful financial and cost related decisions by providing well defined concepts, tools and techniques.

Prerequisite

Nil

Course Outcomes

On the successful completion of the course, students will be able to

CO 1.	Prepare financial statements and analyze them with common size statements, comparative statements and trend percentage methods	Apply
CO 2.	Prepare cost sheet.	Apply
CO3.	Apportionment of overheads to production and service departments, service department overheads to production departments and Allocation of overheads based on the activities performed.	Apply
CO 4.	Prepare various functional budgets and cash budget and Calculation of material, labour and overhead cost variance and to identify the reasons for the variances.	Apply
CO 5.	Evaluate the probability of capital budgeting decisions by using pay back, accounting rate of return, net present value and internal rate of return methods and estimation of working capital management.	Apply

Mapping with Programme Outcomes

COs	PO1	PO2	PO3	PO4	PO5	PO6	PO7	PO8	PO9	P10	P11	P12
CO1	L	L	L	L	L	L	L	M	M	L	S	L
CO2	M	M	L	L	L	L	L	M	M	M	S	L
CO3	M	M	L	L	L	M	L	M	L	S	S	L
CO4	L	L	L	L	L	M	L	M	L	L	S	L
CO5	L	L	L	L	L	M	L	L	L	M	S	S

S- Strong; M-Medium; L-Low

Assessment Pattern

Bloom's Category	Continuous Assessment Tests			Terminal Examination
	1	2	3	
Remember	20	20	20	20
Understand	30	30	30	30
Apply	50	50	50	50
Analyse	0	0	0	0
Evaluate	0	0	0	0
Create	0	0	0	0

Course Level Assessment Questions

Course Outcome 1 (CO1):

1. Define Accounting.
2. Give the financing functions.
3. Define a ledger.
4. State trial balance.
5. Recall single entity concept.
6. Name the various principles of accounting.
7. Give an example nominal account.
8. Identify how adjustment is done for depreciation in final account.
9. List the various assets and liabilities.
10. Define bad debt.
11. From the following Trial balance of Excellent & co on 31st March 2005 you are required to prepare the trading and profit and loss account and a balance sheet as on that date.

Ledger Balances	Amount in Rs.	Ledger balances	Amount in Rs.
Opening stock	500	Commission received	200
Bills receivable	2250	Purchases returns	250
Purchases	19500	Trade expenses	100
Wages	1400	Office fixtures	500
Insurance	550	Cash in hand	250
Sundry debtors	15000	Cash at bank	2375
Carriage inward	400	Rent and taxes	550
Commission paid	400	Carriage outward	725
Interest on capital	350	Sales	25000
Stationery	225	Bills payable	1500
Sales return	650	Sundry creditors	9825
Capital	8950		

The closing stock was valued at Rs.12,500.

Course Outcome 2 (CO2):

1. Explain the various elements of cost.
2. Discuss the significance of cost accounting in a manufacturing industry.
3. Compare balance sheet and cost sheet.
4. Explain the procedure for preparing the cost sheet for an organization.
5. From the following details prepare a cost sheet for the production of 5000 units for the month of Jan 2005.

Cost particulars	Amount in Rs
Stock of raw-materials on 1.01.2005	10,000
Stock of finished goods on 31.01.2005	12,000
Materials purchased	25,000
Carriage inwards	1500
Direct expenses	700
Factory Rent	1000
Office rent	2000
Depreciation : factory	900
Office	600
Repairs and maintenance: factory	900
Office	600
Lighting : Factory	450
Office	750
Manager's salary	3500
Printing and stationery	1000
Telephone charges	1250
General expenses	800
Salesmen commission	650
Advertising	1250
Opening stock of work-in-process (1.01.2005)	2000
Opening stock of finished goods (1.01.2005)	3000
Closing stock of work-in-process (31.01.2005)	4000
Closing stock of finished goods (31.01.2005)	5000

Course Outcome 3 (CO3):

1. Explain the various types of budgets.
2. Explain the procedure for preparing cash budget.
3. Summarize the advantages of Zero Base Budgeting.
4. Prepare cash budget for the months of March, April, May and June for the following Information with the opening balance on March 1st being Rs.25, 000.

Months	Sales	Purchases	Wages	Office Exp.	Selling Exp.	R & D exp.
Jan	120000	80000	1200	2500	1800	1600
Feb	125000	82000	1300	2600	2000	1720
March	120000	78000	1400	2750	2100	1640
April	130000	85000	1400	2750	1900	1680
May	140000	90000	1300	2600	2000	1760
June	135000	86000	1350	2700	2000	1800

Second Call money on shares to be received in May Rs.20000
 Expected income from investments Rs.5000 in March
 Dividends of Rs.3000 to be received in April
 Machinery expected to sell for Rs. 10000 for cash in April
 Dividend to be paid in May for Rs.6000
 Delay in paying..... wages, office expenses one month
 Selling expenses 1 / 4 month

R &D expenses 1/8 month

Credit allowed by suppliers one month

Credit allowed for customers 20% on sales immediately and remaining in two equal instalments in subsequent months

Machinery purchased in May for Rs.2, 00,000.

Course Outcome 4(CO4):

1. Explain the features of standard costing
2. Explain the procedure for preparing cash budget.

Course Outcome 5(CO5):

1. Identify the various sources of finance
2. Distinguish owner's capital from borrowed capital.
3. Compare preference shares and equity shares.
4. Explain capital budgeting.
5. Explain the advantages and disadvantages of both conventional and non-conventional methods of evaluating capital budgeting.
6. Compare IRR and ARR.
7. Calculate IRR if the project cost is Rs.10000 with life period of 3 years generating an even annual cash inflow of Rs.4000 every year.
8. PSG mills Ltd., is considering two mutually exclusive proposals A and B.

Particulars	Year	Proposal A (in Rs.)	Proposal B (in Rs.)
Expected cash outlay	0	2,25,000	3,75,000
Expected cash flows	1	1,50,000	2,50,000
	2	1,00,000	2,00,000
	3	75,000	1,25,000

Assuming a discount rate of 10% suggest which proposal can be accepted?

Concept Map

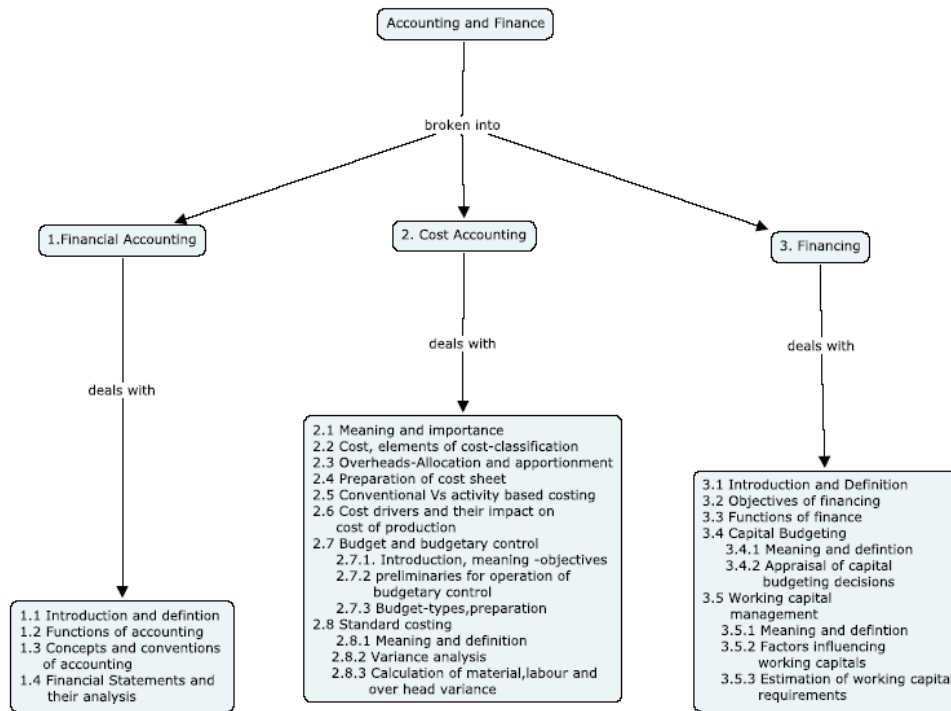

Syllabus

Financial Accounting - Introduction and Definition -Functions of accounting -Concepts and conventions of accounting -Financial statements and their analysis

Cost Accounting - Meaning and importance -Cost-Elements of cost-Cost classification - Overheads –Allocation and apportionment of overheads - Preparation of Cost sheet- Conventional Vs activity based costing -Cost drivers and their impact on costs of production Budget and Budgetary control- Introduction-Meaning -objectives of budgetary control - Preliminaries for operation of budgetary control-Budget-Types of budgets and their preparation - Standard costing-Meaning and definition-Importance -Variance analysis-calculation of material, labour and overhead variances.

Finance -Introduction and Definition-Objectives of financing-Profit maximization vs. wealth maximization -Functions of finance-Capital Budgeting - Introduction-Meaning and Definition-Importance –process of capital budgeting - Appraisal of capital budgeting decisions Working capital - Meaning and definition-Importance-Factors influencing working capital-components of working capital -Estimation of working capital requirements

Text Books

1. M.C.Shukla, T.S.Grewal,S.C.Gupta,“**Advanced Accounts-volume-I**”,Reprint,S.Chand Company Ltd. 2007.
2. S.N.Maheswari, “**Financial Management,principles and practices**”, Sultan Chand & Company Ltd. 2013.

3. P.S.Boopathi Manickam, “**Financial and Management Accounting**” PSG Publications, 2009.

Reference Books

1. Prasanna Chandra, “**Financial Management-Theory and Practice**”. Sixth Reprint, Tata McGraw-Hill publishing company Limited, 2015.
2. RamachandraAryasri, A, RamanaMoorthy, V.V, “**Engineering Economics and financial Accounting**”, Tata McGraw hill, 2007.
3. S.N.Maheswari, “**Advanced accountancy**” Vikas publishing, 2007.

Course Contents and Lecture Schedule

S.No	Topics	No. of Lectures
1.0	Financial Accounting	
1.1	Introduction and Definition	1
1.2	Functions of accounting	1
1.3	Concepts and conventions of accounting	1
1.4	Financial statements	
1.4.1	Comparative statement	2
1.4.2	Common size statement	1
1.4.3	Trend percentage	1
2.0	Cost Accounting	
2.1	Meaning and importance	1
2.2	Cost-Elements of cost-Cost classification	1
2.3	Overheads – Allocation and apportionment of overheads	1
2.4	Preparation of Cost sheet	2
2.5	Conventional Vs Activity based costing	1
2.6	Cost drivers and their impact on costs of production	1
2.7	Budget and Budgetary control	
2.7.1	Introduction-Meaning -objectives of budgetary control	1
2.7.2	Preliminaries for operation of budgetary control	1
2.7.3	Budget-Types of budgets and their preparation	2
2.8	Standard costing	
2.8.1	Meaning and definition-Importance	1
2.8.2	Variance analysis-calculation of material, labour and overhead variances.	1
2.8.3	Calculation of material, labour and overhead variances.	1
3.0	Finance	
3.1	Introduction and Definition	1
3.2	Objectives of financial management	1
3.3	Functions of finance	1
3.4	Capital Budgeting	
3.4.1	Introduction-Meaning and Definition-Importance –process of capital budgeting	1
3.4.2	Appraisal of capital budgeting decisions	1
3.4.3	Payback Period, ARR	2

S.No	Topics	No. of Lectures
3.4.4	NPV, IRR and PI methods	2
3.5	Working capital Management	
3.5.1	Meaning and definition-Importance	1
3.5.2	Factors influencing working capital-components of working capital	2
3.5.3	Estimation of working capital requirements	2
Total		35

Course Designers:

1. Dr. S. Boopathimanickam pbmeci@tce.edu
2. Mr.M.M.Devarajan m.mdevarajan@gmail.com



14MT620

INDUSTRIAL ROBOTICS

Category	L	T	P	Credit
PC	3	0	0	3

Preamble

Robotics is the applied science of motion control for multi-axis manipulators and is a large subset of the field of "Mechatronics" (Mechanical, Electronic and Software engineering for product or systems development, particularly for motion control applications). Robotics, sensors, actuators and controller technologies are continuously improving and evolving synergistically. In the 20th century, engineers have mastered almost all forms of motion control and have proven that robots and machines can perform almost any job that is considered too heavy, too tiring, too boring or too dangerous and harmful for human beings. This course supports the students to design and develop multi-DOF manipulators.

Prerequisite

- 14MA110 - Engineering Mathematics I
- 14MT320 - Kinematics and Dynamics of Machinery

Course Outcomes

On the successful completion of the course, students will be able to

CO1 :	Describe the working of the subsystems of robotic manipulator and mobile robot	Understand
CO2:	Develop the <i>forward kinematic model</i> of multi-degree of freedom (DOF) manipulator (for determining the position of end-effectors with respect to base) and <i>inverse kinematic model</i> (two degrees of freedom robot arm and wheeled robot) and <i>dynamic model</i> of two degrees of freedom robot arm	Apply
CO3:	Develop a cubic polynomial trajectory in joint space with given kinematic constraints of multi-degree of freedom (DOF) manipulator	Apply
CO4:	Explain various types of control schemes, sensors and interfaces used in the operation of robot/ with the robot controller	Understand

Mapping with Programme Outcomes

COs	PO1	PO2	PO3	PO4	PO5	PO6	PO7	PO8	PO9	PO10	PO11	PO12
CO1.	L			S								
CO2.	S	M	L	S		S						M
CO3.	S	M	L	S		S						M
CO4.	L			S		S						M

S- Strong; M-Medium; L-Low

Assessment Pattern

Bloom's Category	Continuous Assessment Tests			Terminal Examination
	1	2	3	
Remember	20	20	20	10
Understand	20	20	20	30
Apply	60	60	60	60
Analyse	-	-	-	-
Evaluate	-	-	-	-
Create	-	-	-	-

Course Level Assessment Questions

Course Outcome 1 (CO1):

1. Define industrial robot.
2. Explain the classification of actuators used in robotic manipulators and indicate their advantages and limitations.
3. Describe the construction features of an industrial robot.
4. With use of simple sketches, explain the working of castor wheel for steering a mobile robot.

Course Outcome 2 (CO2):

1. Write the coordinate transformation matrices for all PUMA joints as shown in figure 1 using DH parameters.

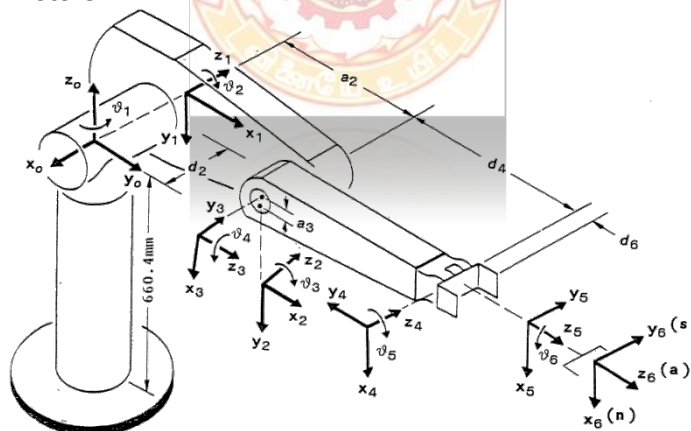

Figure 1

2. Consider the two-link planar arm of Figure 2. The joint axes z_0 and z_1 are normal to the page. The established base frame $x_0y_0z_0$ is as shown. The origin is chosen at the point of intersection of the z_0 axis with the page and the direction of the x_0 axis is completely arbitrary. Once the base frame is established, the $x_1y_1z_1$ frame is fixed as shown by the DH convention, where the origin, o_1 has been located at the intersection of z_1 and the page. The final frame $x_2y_2z_2$ is fixed by choosing the origin, o_2 at the end of link 2 as shown. Write the DH parameters and its corresponding transformation matrices.

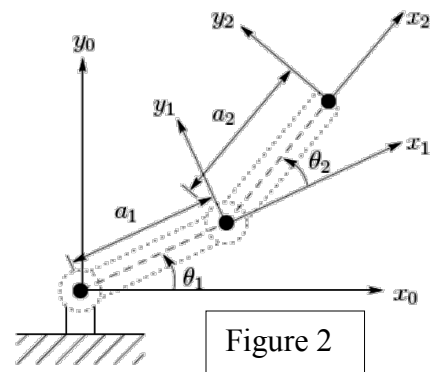

Figure 2

- Develop a dynamic model for two degree of freedom manipulator as shown in figure 2.

Course Outcome 3 (CO3):

- Explain step by step procedure for the generation a cubic polynomial trajectory for a joint with specified kinematic constraints.
- The initial and final joint positions of a robot joint are $\theta_i = 15^\circ$ and $\theta_f = 75^\circ$ with time period of 3 sec. The following expressions are governing equations for position, velocity and acceleration. Develop a trajectory for the above conditions.

$$\theta(t) = 15 + 20t^2 - 4.44t^3$$

$$\theta'(t) = 40t - 13.32t^2$$

$$\theta''(t) = 40 - 26.64t$$

- Develop a trajectory for a robot whose initial and final position are given as $\theta_i = -45^\circ$ and $\theta_f = 15^\circ$ and governing equation is $\theta(t) = -45 + 24t + 4t^2$. Determine the time period for this trajectory.

Course Outcome 4 (CO4):

- Name any four sensors used in robot as internal sensor.
- Explain the classification of the sensors used in robotic applications.
- Explain the general control architecture of robotic system with suitable block diagram.

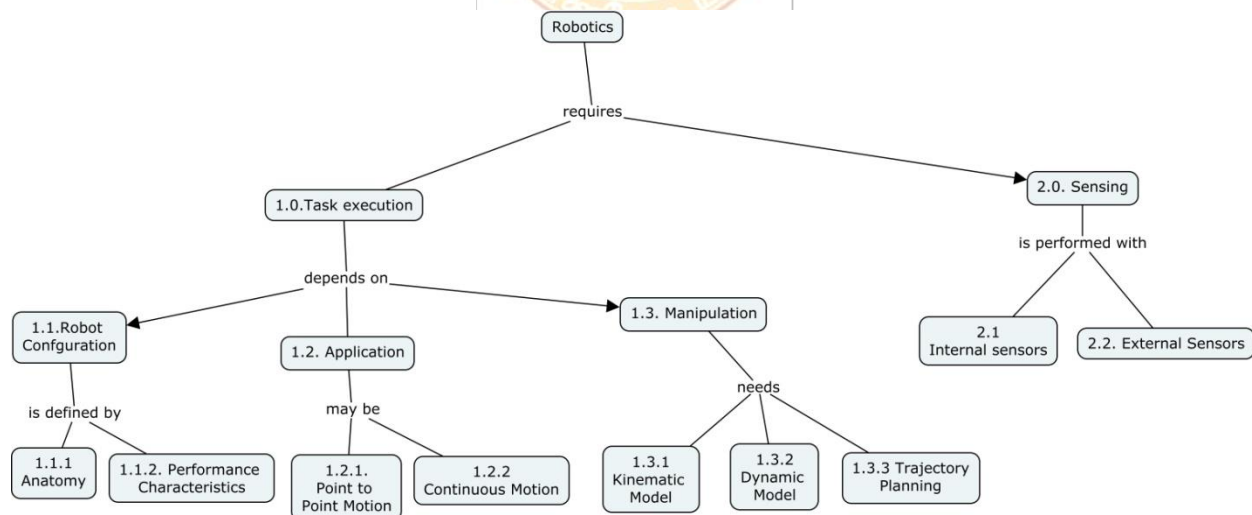
Concept Map**Syllabus**

Introduction to Robotics.

Task Execution: Robot Configuration - Robot Anatomy, Sub- systems/Elements of Industrial Robot - Performance characteristics of industrial Robots. Mobile robot locomotion: Introduction, key issues for locomotion, wheeled locomotion-wheel design, geometry, stability, manoeuvrability and controllability. Applications - Progressive advancement in Robots – Point to point and continuous motion applications - Mobile manipulators and its applications.

Manipulation: Kinematic model - Forward Kinematics for two DOF manipulator – Algebraic method, Mechanical structure and notations, Coordinate frames, Description of objects in space, Transformation of vectors, Fundamental rotation matrices (principal axes and fixed angle rotation) Description of links and joints, Denavit-Hartenberg (DH) notation, Forward Kinematics for multi-Degrees of Freedom (DOF) manipulator. Inverse kinematics of two DOF manipulator - Manipulator workspace.

Dynamic model: Lagrangian method - Forward and inverse dynamic model for two DOF manipulator.

Trajectory planning: Definitions and planning tasks, Joint space techniques – Motion profiles – Cubic polynomial motion - Cartesian space techniques.

Sensors: Robotic sensors and its classification, characterizing sensor performance, Internal sensors – motion/speed sensors - wheel or motor sensors - optical encoder, Hall effect sensor. External Sensors – Contact sensors- Limit switches, piezoelectric, Tactile sensors: pressure pads, Non-contact sensors - proximity sensor - capacitive, inductive and Infra-red. Architecture of robotic vision system - heading sensors, ground-based beacons, active ranging.

Text Books

1. S.K.Saha, “**Introduction to Robotics**”, Second Edition, McGraw Hill Education (India) Private Limited, New Delhi, 2014.
2. Roland Siegwart and Illah R.Nourbakhsh, “**Introduction to Autonomous Mobile Robots**”, Prentice Hall of India (P) Ltd., 2005

Reference Books

1. K.S. Fu, R.C Gonzalez and C.S. Lee, “**Robotics- Control, Sensing, Vision and Intelligence**”, Tata McGraw-Hill Editions, 2008
2. John J.Craig, “**Introduction to Robotics, Mechanics and control**”, third edition, Pearson education, 2005.
3. Mark W.Spong, M.Vidyasagar, “**Robot dynamics and control**”, Wiley India, 2009.
4. Mikell P. Groover, Mitchell Weiss, Roger N.Nagel and Nicholas G. Odrey, “**Industrial Robotics” – Technology, Programming and Applications**” Tata McGraw-Hill Edition, 2008.
5. Yoram Koren, “**Robotics for Engineers**”, McGraw-Hill Book Co., 1992.
6. Janakiraman.P.A., “**Robotics and Image Processing**”, Tata McGraw-Hill, 1995.
7. George A. Bekey, “**Autonomous Robots – From Biological Inspiration to Implementation and control**”, MIT Press, 2005.
8. Howie Choset, Kevin M. Lynch, Seth Hutchinson, George A. Kantor, Wolfram Burgard, Lydia E. Kavraki and Sebastian Thrun, “**Principles of Robot Motion – Theory, Algorithms and Implementation**”, MIT Press, 2005.

Course Contents and Lecture Schedule

Module No.	Topic	No. of Lectures
1.	Task Execution:	
1.1	Robot Configuration - Robot Anatomy	2
1.1.1	Sub- systems of Industrial Robot	1
1.1.2	Mobile robot locomotion: Introduction, key issues for locomotion,	2
1.1.3	wheeled locomotion - wheel design, geometry	1
1.1.4	Stability, manoeuvrability and controllability	2
1.1.2	Performance characteristics of industrial Robots.	2
1.2	Applications - Progressive advancement in Robots – Point to point and continuous motion applications - Mobile manipulators and its applications.	1
1.3	Manipulation:	
1.3.1	Kinematic model - Forward Kinematics for two DOF manipulator – Algebraic method,	2
1.3.1.1	Mechanical structure and notations, Coordinate frames, Description of objects in space,	2
1.3.1.2	Transformation of vectors, Fundamental rotation matrices (principal axes and fixed angle rotation)	2
1.3.1.3	Description of links and joints, Denavit-Hartenberg (DH) notation,	2
1.3.1.4	Forward Kinematics for multi-Degrees of Freedom (DOF) manipulator.	2
1.3.1.5	Inverse kinematics of two DOF manipulator - Manipulator workspace.	2
1.3.2	Dynamic model: Lagrangian method - Forward dynamic model for two DOF manipulator.	2
1.3.2.1	Inverse dynamic model for two DOF manipulator.	2
1.3.3	Trajectory planning: Definitions and planning tasks, Joint space	2
1.3.3.1	Motion profiles – Cubic polynomial motion - Cartesian space	2
2.	Sensors: Robotic sensors and its classification, characterizing sensor performance,	1
2.1	Internal sensors – motion/speed sensors - wheel or motor sensors, optical encoder, Hall effect sensor	1
2.2	External Sensors – Contact sensors- Limit switches, piezoelectric	1
2.2.1	Tactile sensors: pressure pads,	1
2.2.2	Non-contact sensors - proximity sensor- capacitive, inductive and Infra-red.	1
Total		36

Course Designers:

- | | | |
|----|-------------------------|-------------------------|
| 1. | Dr. S.Saravana Perumaal | sspmech@tce.edu |
| 2. | Mr.S.Parthasarathi | parthasarathi_s@tce.edu |

14MT630 MECHATRONICS SYSTEM DESIGN

Category	L	T	P	Credit
PC	3	0	0	3

Preamble

A Mechatronic system design is a design process that is characterized by synergistic integration of mechanisms, sensors, actuators and control to perform complex tasks in a metaphysical environment. An important characteristic of mechatronic devices and systems is their built-in intelligence, which results through a combination of precision mechanical and electrical engineering and real-time programming integrated with the design process. Mechatronics system design makes possible to understand the basic design process involved in mechatronics, selection of sensors and actuators, the interface issues and communication problems. Design of a mobile robot is introduced in this subject to illustrate the concepts.

Prerequisite

- 14MT330 - Sensors and PLC
- 14MT420 – Engineering Design
- 14MT430 – Analog and Digital circuit Design
- 14MT520 - Control System

Course Outcomes

On successful completion of the course, students will be able to

CO 1	Discuss about modelling of Mechatronic System	Understand
CO 2	Explain the design process involved in mechatronics	Understand
CO 3	Select the sensor and Actuator for a Mechatronic application	Apply
CO 4	Develop a Mechatronic product for the given problem	Apply

Mapping with Programme Outcomes

COs	PO1	PO2	PO3	PO4	PO5	PO6	PO7	PO8	PO9	PO10	PO11	PO12
CO1.	L	M	S	S	-	-	S	-	-	M	L	S
CO2.	L	L	S	S	-	-	-	-	-	M	L	S
CO3.	L	S	L	M	M	-	-	-	-	L	L	M
CO4.	L	S	L	M	L	-	M	-	-	L	L	L

S- Strong; M-Medium; L-Low

Assessment Pattern

Bloom's Category	Continuous Assessment Tests			Terminal Examination
	1	2	3	
Remember	20	20		20
Understand	20	40		40
Apply	60	40	100	40
Analyse	-	-	-	-
Evaluate	-	-	-	-
Create	-	-	-	-

Course Level Assessment Questions**Course Outcome 1 (CO1):**

1. Describe modelling.
2. Explain various modelling methods of a Mechatronic system.
3. Describe the basic components of bond graphs
4. Draw the bond graph model of DC series Motor

Course Outcome 2(CO2):

1. Does Conceptual Design help in real life problems? If yes, how?
2. Choose the sensor and actuator for a fire fighting robot.
3. Write any four graphical-based application software used for DAC system with its description.
4. Explain the simulation methods for a real life problem.

Course Outcome 3 (CO3):

1. Draw the driver circuit to control four servo motors of a mobile robot.
2. Discuss real time interfacing? Explain briefly the elements of a data acquisition and control system with neat sketch.
3. For a wall painting robot design control architecture to interface the sensor and actuator and support your choice.

Course Outcome 4 (CO4):

1. Design a mobile robot which moves along a room and paints the wall at a height of 3m from the ground. Consider all the mechanical alternatives and draw all possible designs. Choose sensor, actuator, communication and interface method for all designs. The robot of mass 3 kg should reach the maximum velocity in 1 s, so an acceleration of 0.15m/s^2 is desired. The wheel radius is assumed to be 3 cm. Calculate the maximum torque and required power. According to the design considered, choose a differential (gear reduction mechanism) to

raise the spray gun to a particular height. Design optimum motor driving circuitry, signal conditioning circuit and algorithm for smooth functioning of the robot.



2. For a beam of length 0.285 m, width 0.0254 m, thickness 0.003 m, modulus 70.3 N/m², density 2712 kg/m³, Obtain an optimum beam experimental setup. Assume that the beam is divided into 10 finite beams. To measure the vibration levels of the beam, Consider a sensor – actuator is tightly bounded and placed below the beam. The moment generated is proportional to the voltage of the sensor. Model the sensor and PZT actuator. According to the voltage generated, develop the instrumentation setup (charge amplifier), signal conditioning circuit, Controller and software. Explain the algorithm of working.
3. If a robot of length 31cm, 31cm wide and 27 cm height, mass 3 kg is used to extinguish fire in a room, Explain the mechanical alternatives, types of materials used in the construction of robot. A candle is used to set the flame 15cm to 20 cm above the floor level. The robot should extinguish the flame in 50 secs. The motor is energized by a driver circuit (H Circuit). Select a suitable gear ratio to lift the CO₂ spray gun with an acceleration of 0.34 m/s². Calculate the maximum torque and power needed.

Concept Map

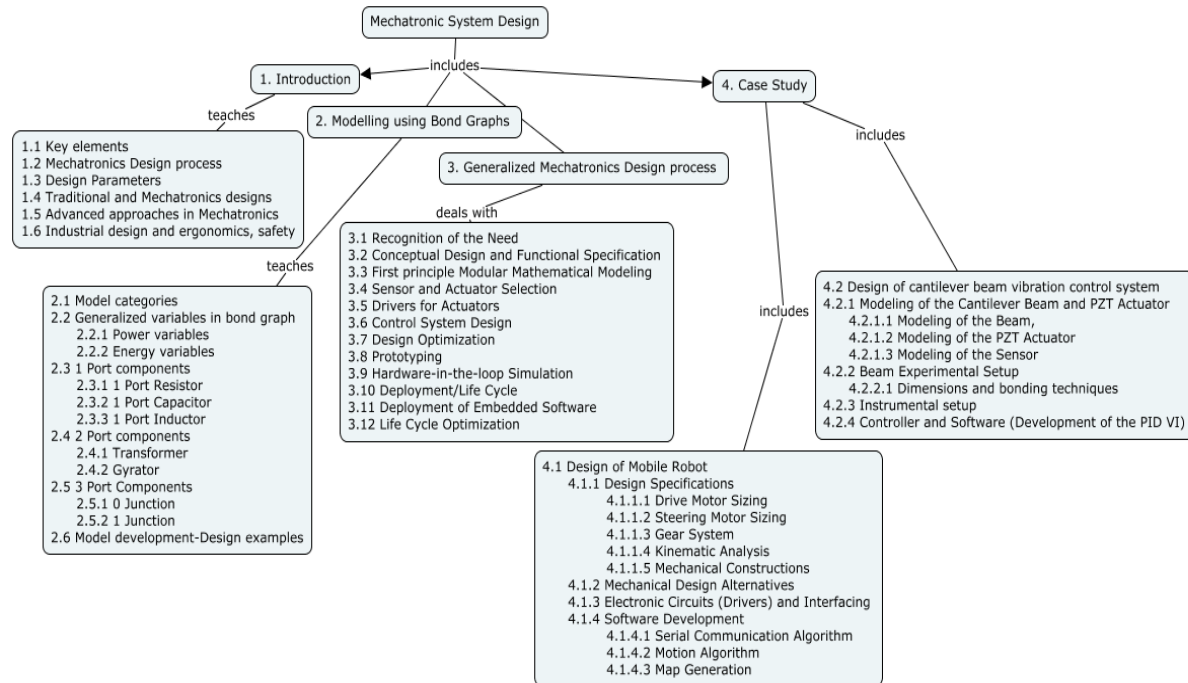

Syllabus

Introduction to Mechatronic System Design:

Key elements – Mechatronics Design process – Design Parameters – Traditional and Mechatronics designs – Advanced approaches in Mechatronics - Industrial design and ergonomics, safety.

System Modelling by Bond Graphs:

Introduction-model categories-fields of application, generalized variables in bond graph- Power variables – Energy variables, Basic components in Bond graph-1 Port components- 1 Port Resistor- 1 Port Capacitor – 1 Port Inductor, 2 Port components- Transformer- Gyrator, 3 Port Components – 0 Junction, 1 Junction, Model development-Design examples.

Generalized Mechatronics Design Process:

Recognition of the Need, Conceptual Design and Functional Specification, First principle Modular Mathematical Modeling, Sensor and Actuator Selection, Drivers for Actuators, Control System Design, Design Optimization, Prototyping, Hardware-in-the-loop Simulation, Deployment/Life Cycle, Deployment of Embedded Software, Life Cycle Optimization.

Case Study: Design of Mobile Robot -Introduction, , Design Specifications (Drive Motor Sizing, Steering Motor Sizing, Gear System, Kinematic Analysis, Mechanical Constructions), Mechanical Design Alternatives, Electronic Circuits (Drivers) and Interfacing (Sensors, Serial Communication Circuit, Robot Circuitry, Motor Driving Circuitry, Communication Strategy), Software Development (Serial Communication Algorithm, Motion Algorithm, Map Generation).

Design of cantilever beam vibration control system based on piezo sensors and actuators - Introduction, Modeling of the Cantilever Beam and PZT Actuator (Modeling of the Beam, Modeling of the PZT Actuator, Modeling of the Sensor), Beam Experimental Setup (properties and dimensions of the beam, dimensions and bonding techniques), instrumental setup (Charge amplifier, Voltage amplifier, Data Acquisition), Controller and Software (Development of the PID VI)

Text Books

1. Shruva Das, "**Mechatronic Modelling and Simulation Using Bond Graphs**" CRC Press, 2009.
2. W. Bolton, "**Mechatronics – Electronic control systems in Mechanical & Electrical Engineering**", Pearson Education Ltd., 2003.
3. Shetty and Kolk , "**Mechatronics System Design**" , CENGAGE Learning, India, second edition, 2011.

Reference Books

1. Bishop, Robert H, "**Mechatronics Hand book**", CRC Press, 2002.
2. Kenji Uchino and Jayne R. Giniewicz, "**Mechatronics**" publication: Marcel Dekker, Inc.
3. A. Smaili and F. Mrad, "**Applied Mechatronics**", OXFORD university publication April 2008.

Course Contents and Lecture Schedule

Sl. No.	Topic	No. of Lectures
1	Introduction to Mechatronic System Design	
1.1	Key elements – Mechatronics Design process	1
1.2	Design Parameters – Traditional and Mechatronics designs	1
1.3	Advanced approaches in Mechatronics - Industrial design and ergonomics, safety.	2
2	System Modelling by Bond Graphs	
2.1	Introduction-model categories-fields of application	1
2.2	Variables in bond graph- Power variables – Energy variables	1
2.3	Basic components in Bond graph-1 Port components	1
2.4	2 Port components- Transformer- Gyrator	1
2.5	3 Port Components – 0 Junction, 1 Junction	1
2.6	Design Examples	1
3	Generalized Mechatronics Design Process	
3.1	Recognition of the Need, Conceptual Design and Functional Specification	1
3.2	First principle Modular Mathematical Modeling	1
3.3	Sensor Selection	2
3.4	Actuator Selection	2
3.5	Drivers for Actuators	1
3.6	Control System Design	1
3.7	Communication Strategy	1

Sl. No.	Topic	No. of Lectures
3.8	Software Development	1
3.9	Design Optimization	1
3.10	Prototyping	1
3.11	Hardware-in-the-loop Simulation	1
3.12	Deployment/Life Cycle, Deployment of Embedded Software, Life Cycle Optimization	1
4	Case Study:	
4.1	Design of Mobile Robot – Introduction	1
4.2	Design Specifications (Drive Motor Sizing, Steering Motor Sizing, Gear System, Kinematic Analysis, Mechanical Constructions)	
4.3	Mechanical Design Alternatives	1
4.3	Electronic circuits (Drivers).	2
4.4	Interfacing (Sensors, Serial Communication Circuit, Robot Circuitry, Motor Driving Circuitry, Communication Strategy)	2
4.5	Software Development (Serial Communication Algorithm, Motion Algorithm, Map Generation)	2
4.6	Design of cantilever beam vibration control system based on piezo sensors and actuators – Introduction	1
4.7	Modeling of the Cantilever Beam and PZT Actuator (Modeling of the Beam, Modeling of the PZT Actuator, Modeling of the Sensor)	2
4.8	Beam Experimental Setup (properties and dimensions of the beam, dimensions and bonding techniques)	2
4.9	Instrumental setup (Charge amplifier, Voltage amplifier, Data Acquisition),	2
4.10	Controller and Software (Development of the PID VI)	1
Total Hours		40

Course Designers:

- | | | |
|------------------|---|----------------------|
| 1. Mr T Vivek | - | tvivek@tce.edu |
| 2. Mr M.A Ganesh | - | ganeshma2015@tce.edu |

14MT640**DIGITAL SIGNAL PROCESSING**

Category	L	T	P	Credit
PC	2	1	0	3

Preamble

Signal processing is concerned with the representation, transformation and manipulation of signals and the information they contain. It is an area of science and engineering that has developed rapidly over the past few decades. Digital Signal Processing and digital systems are attracting more attention, due in large part to the significant advantages of digital systems over their analog counterparts. These advantages include superiority in performance, speed, reliability, efficiency of storage, size and cost.

Prerequisite

- NIL

Course Outcomes

On the successful completion of the course, students will be able to

CO1	Differentiate between the various digital signals such as periodic/apperiodic, Energy/Power, Even/Odd, Causal/Non Causal and systems such as Static/Dynamic, Linear/Non-Linear, Time Variant/Time Invariant, Causal/Non-Causal	Understand
CO2	Describe the process of sampling and the effects of under sampling	Understand
CO3	Compute DFT and IDFT coefficients of a given discrete time sequence using Fast Fourier Transform algorithms.	Apply
CO4	Draw the implementation structure of IIR and FIR systems using block diagram and signal flow graph representation.	Apply

Mapping with Programme Outcomes

COs	PO1	PO2	PO3	PO4	PO5	PO6	PO7	PO8	PO9	PO10	PO11	PO12
CO1	S	M	L	-	L	-	-	-	L	L	-	M
CO2	S	M	L	-	L	-	-	-	L	L	-	M
CO3	S	M	L	-	M	-	-	-	L	L	-	M
CO4	S	S	M	M	M	-	-	-	L	L	-	M

S - Strong; M - Medium; L - Low

Assessment Pattern

Bloom's Category	Continuous Assessment Tests			Terminal Examination
	1	2	3	
Remember	20	20	20	20
Understand	40	40	40	40
Apply	30	30	30	30
Analyse	10	10	10	10
Evaluate	0	0	0	0
Create	0	0	0	0

Course Level Assessment Questions

Course Outcome 1 (CO1):

1. Determine whether the following signals are power, energy or neither energy nor power signals
 - a. $x(n) = \left(\frac{1}{3}\right)^n u(n)$
 - b. $x(n) = e^{2n} u(n)$
 - c. $x(n) = \sin\left(\frac{\pi}{4}n\right)$
 - d. $x(n) = e^{j\left(\frac{\pi}{2}n + \frac{\pi}{4}\right)}$

Course Outcome 2 (CO2):

1. Describe the process of sampling necessary diagrams.
2. Explain the causes of aliasing
3. Define Nyquist criteria

Course Outcome 3 (CO3):

1. Determine the Fourier transform $X(\omega)$ of the signal $x(n) = \{1, 2, 3, 2, 1, 0\}$
2. Compute the 6 point DFT $V(k)$ of the signal $v(n) = \{3, 2, 1, 0, 1, 2\}$
3. Consider the sequences
 $x_1(n) = \{0, 1, 2, 3, 4\}$, $x_2(n) = \{0, 1, 0, 0, 0\}$
 Determine the sequence $y(n)$ such that $Y(k) = X_1(k) \cdot X_2(k)$
4. Determine the eight point DFT of the signal $x(n) = \{1, 1, 1, 1, 1, 1, 0, 0\}$ using DIF and DIT algorithms

Course Outcome 4 (CO4):

1. Consider an FIR filter with system function $H(z) = 1 + 2.88z^{-1} + 3.404z^{-2} + 1.74z^{-3} + 0.4z^{-4}$. Sketch the parallel form and cascade realizations of the filter.
2. Determine a direct form realization for the following linear phase filters:
 - a. $h(n) = \left\{\frac{1}{4}, 2, 3, 4, 3, 2, 1\right\}$
 - b. $h(n) = \left\{\frac{1}{4}, 2, 3, 3, 2, 1\right\}$

Concept Map

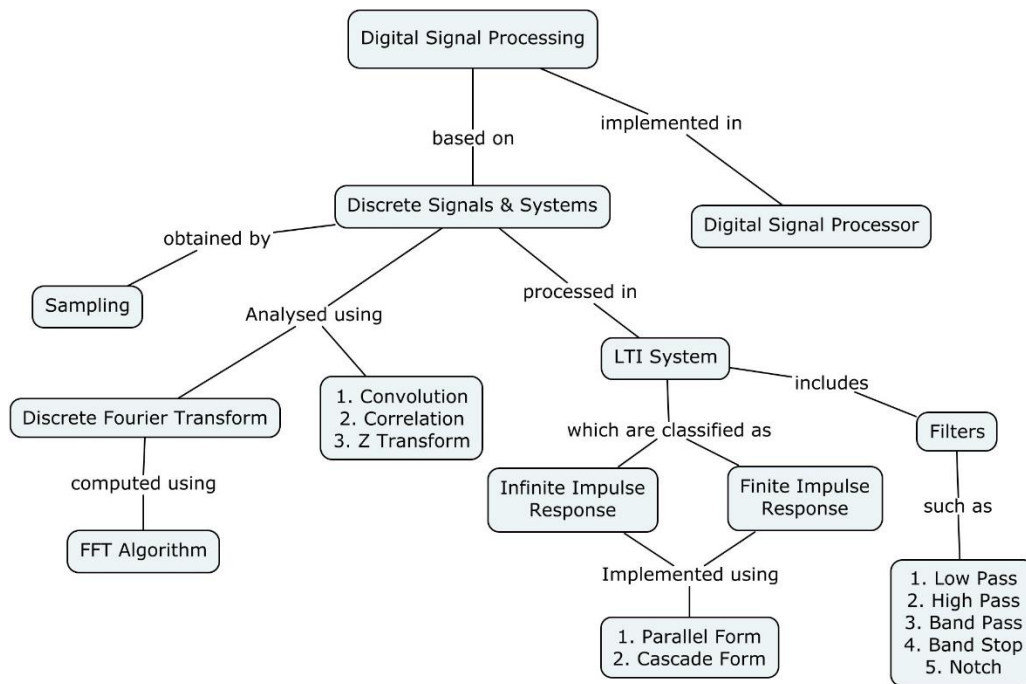

Syllabus

Signals and Systems: Continuous and Discrete Time Signals; Step, Ramp, Pulse, Impulse, Exponential; Classification of signals – periodic and aperiodic, random signals, Energy and Power signals, Even and Odd, Causal and Non Causal; Continuous and Discrete time systems; Classification of systems – Static and Dynamic, Linear and Non-Linear, Time Variant and Time Invariant, Causal and Non-Causal.

Analysis of Discrete Time Signals: Sampling of Continuous Time Signals, Aliasing, Reconstruction, Quantization; Impulse Response, Convolution – linear, circular; Correlation; Z-Transform and its properties, Inverse Z-Transform.

Discrete Fourier Transform: Discrete Fourier Transform, Properties, Magnitude and Phase Response; Inverse Discrete Fourier Transform; Computation of Discrete Fourier Transform and Inverse Discrete Fourier Transform using Fast Fourier Transform algorithm – Decimation In Time and Decimation in Frequency using radix 2, Butterfly structure.

Digital Filters: Introduction to Filters, Low Pass, High Pass, Band Pass, Band Stop, Notch Filters; Finite & Infinite Impulse Response Filter Realization - Parallel & cascade forms;

Digital Signal Processor: Introduction, Von Neumann and Harvard Architecture, Multiply Accumulate Unit, Pipelining; Architecture of TMS320C50, Features, Addressing Formats; Applications of Digital Signal Processors.

Software simulation of discrete time signals, convolution, correlation, sampling, effects of under sampling, design of filters.

Text Books

1. Ashok Ambardar, "**Digital Signal Processing: A Modern Introduction**", Cengage Learning, First Edition, 2007
2. John G.Proakis and Dimitris G.Manolakis, "**Digital Signal Processing Principles, Algorithms and Applications**", Prentice-Hall of India, Fourth Edition, 2014.

Reference Books

1. Richard G. Lyons "**Understanding Digital Signal Processing**", Pearson Education India; third edition, 2010.
2. P.Ramesh Babu, "**Digital Signal Processing**" Scitech publications, 2011.
3. S.Salivahanan, A.Vallavaraj and C.Gnanapriya "**Digital Signal Processing**", Tata McGraw Hill, Third Edition, 2014.
4. B.Venkatramani & M.Bhaskar, "**Digital Signal Processors architecture, Programming and Applications**", Tata McGraw Hill, 2002.

Course Contents and Lecture Schedule

Sl. No.	Topic	No. of Lectures
1	Signals and Systems	
1.1	Continuous and Discrete Time Signals; Step, Ramp, Pulse, Impulse, Exponential;	1
1.2	Classification of signals – periodic and aperiodic, random signals, Energy and Power signals; Even and Odd, Causal and Non Causal;	3
1.3	Continuous and Discrete time systems; Classification of systems – Static and Dynamic, Linear and Non-Linear, Time Variant and Time Invariant, Causal and Non-Causal.	2
2	Analysis of Discrete Time Signals	
2.1	Sampling of Continuous Time Signals, Aliasing,	3
2.2	Reconstruction, Quantization;	2
2.3	Impulse Response, Convolution - linear, circular; Correlation	3
2.4	Z-Transform and its properties	2
2.6	Inverse Z-Transform.	2
3	Discrete Fourier Transform	
3.1	Discrete Fourier Transform, Properties, Magnitude and Phase Response;	3
3.2	Inverse Discrete Fourier Transform	2
3.3	Computation of Discrete Fourier Transform using Fast Fourier Transform algorithm – Decimation In Time using radix 2, Butterfly structure.	2
3.4	Decimation in Frequency using radix 2, Butterfly structure.	2
3.5	Computation of Inverse Discrete Fourier Transform using Fast Fourier Transform algorithm	1
4	Digital Filters	
4.1	Introduction to Filters, Filter Types, Finite & Infinite Impulse Response Filter	3
4.2	Finite & Infinite Impulse Response Filter Realization	2

5	Digital Signal Processor	
5.1	Introduction, Von Neumann and Harvard Architecture, Multiply Accumulate Unit, Pipelining;	2
5.2	Architecture of TMS320C50, Features, Addressing Formats;	2
5.3	Applications of Digital Signal Processors	1
5.4	Software simulation of discrete time signals	2
5.5	convolution, correlation;	2
5.6	sampling, effects of under sampling; design of filters;	4
Total		46

Course Designers:

1	Ramesh H	rameshh@tce.edu
2	Sheik Masthan S.A.R	sarsmech@tce.edu



14MT680**DYNAMICS AND CONTROL LAB**

Category	L	T	P	Credit
PC	0	0	2	1

Preamble

Dynamic response of a system is often a key factor in system's overall performance. The design of modern, quiet and efficient engineering systems requires a good understanding of dynamic response. Dynamics is the field of engineering concerned with predicting, measuring and analysing the behaviour responses such as force, torque, speed, mass, velocity and acceleration.

Control engineering concerns the design of automatic systems to control the behaviour of machines and processes. Effective control system design is critical in achieving optimal performance from machines and processes, and is dependent on a good understanding of the dynamics of the system that is to be controlled. Therefore understanding the natural link between the fields of dynamics and control plays a vital role in modern engineering systems.

Prerequisite

- 14MT220 Free body mechanics
- 14MT320 Kinematics and Dynamics of Machinery
- 14MT520 Control system

Course Outcomes

On successful completion of the course, students will be able to

CO1	Analyse and predict the dynamic response of rotating systems behaviour such as force, torque, speed and mass.	Apply
CO2	Design and implement PID controller using ZN tuning technique in practical/simulation environment	Apply
CO3	Design Controller based on the specifications by root locus and/or frequency domain analysis	Apply

Mapping with Program Outcomes

COs	PO1	PO2	PO3	PO4	PO5	PO6	PO7	PO8	PO9	P10	P11	P12
CO1	S	M	S	S	S	M	-	-	S	M	M	S
CO2	S	M	S	S	S	M	-	-	S	M	M	S
CO3	L	L	-	S	S	-	-	-	S	M	L	S

S- Strong; M-Medium; L-Low

Syllabus

List of experiments		
Ex.No	Experiments/Exercises	Hours
CYCLE 1 - DYNAMICS LAB		
1.	Governors - Determination of sensitivity, effort, etc. for watt, porter, proell, Hartnell governors	2
2.	Cam - Study of jump phenomenon and drawing profile of the cam.	2

3.	Motorized Gyroscope-Determination of Gyroscopic couple Verification of Laws.	2
4.	Turn table-Determination of Moment of Inertia of Disc and Ring.	2
5.	Balancing of rotating masses (Static and Dynamic Balancing)	2
6.	Balancing of reciprocating masses.	2
7.	Whirling of Shaft – Determination of Critical Speed	2
CYCLE 2 - CONTROL LAB		
1.	Obtain the transfer function using bode plot.	2
2.	Design a suitable compensator to obtain the open loop specifications using root locus and bode plot techniques.	2
3.	Design of P, PI and PID controller for Pneumatic system using ZN technique.	2
4	Design a RLC circuit as un damped, under damped, critically damped and over damped system. The output voltage taken across the resistor.	2
5	For the transfer function of the RLC circuit obtain closed loop step response, and time domain specifications.	2
6	To obtain the closed loop response of a First order plus dead time system with Ziegler–Nichols P, PI, and PID controllers for various L/T ratios.	2
7	To derive the relationship between repeated poles and dead time for a type 0 system.	2
8	DC motor speed controller using PID tuning.	2
	Total	24

Minimum of 12 experiments are to be given

Course Designers:

1. Dr.G.Kanagaraj - gkmech@tce.edu
 2. Ms. S. Siva Priya - siva2692@hotmail.com

14MT690**ROBOTICS LABORATORY**

Category	L	T	P	Credit
PC	0	0	2	1

Preamble

Robotics is the prominent component of manufacturing automation which will affect human labor at all levels, from unskilled workers to professional engineers and managers of production. Future robots may applications outside of the factory in banks, restaurants, and even homes.

Course Outcomes

On successful completion of the course, students will be able to

CO1.	Implement the programming and control of robots	Apply
CO2.	Predict the Path and trajectory planning for given environment	Apply

Mapping with Programme Outcomes

COs	PO1	PO2	PO3	PO4	PO5	PO6	PO7	PO8	PO9	PO10	PO11	PO12
CO1	S	M	S	M	S	S	M	L	M	M	L	S
CO2	S	L	L	L	S	S	M	L	M	M	S	S

S- Strong; M-Medium; L-Low

List of Experiments

S.No.	Exercises / Experiments
1.	Denavit- Hartenberg parameters visualization using Robo analyzer software
2.	Creating robot joint trajectories using Robo analyzer software
3.	Determine the trajectory of end-effector to base, link to link and draw the graph respectively by applying forward kinematics method.
4.	Implementation of trajectory planning algorithm for straight line motion using Matlab
5.	Simulation of Forward and Inverse Kinematics using Robo Analyzer
6.	Simulation of Workspace Analysis of a 6 axis robot
7.	Forward and inverse kinematics using QBot 2
8.	Odometric Localization and Dead Reckoning using QBot 2
9.	Robot Localization using particle filtering by Qbot2
10.	Occupancy Grid Mapping using QBot 2
11.	Vision-guided vehicle control using QBot 2
12.	Path planning and Obstacle Avoidance using QBot 2

Course Designers

- | | | |
|-------------------|---|----------------------|
| 1. S.Julius Fusic | - | sjf@tce.edu |
| 2. M.A.Ganesh | - | ganeshma2015@tce.edu |
| 3. A.Prakash | - | apmech@tce.edu |



14MT710

PROJECT MANAGEMENT

Preamble

Management in business and human organization activity is simply the act of getting people together to accomplish desired goals. Qualified project managers are in high demand in this competitive world. This course focuses on project management methodology that will increase your ability to initiate and manage projects more efficiently and effectively. The Project Management course discusses activities of planning, organizing, motivating, controlling resources and leadership in theory and practice and the roles and responsibilities of the project manager. It deals with approaches to achieve the project goals and to optimize the allocation of necessary inputs and to integrate them. The course is based on references from Project Management Institute's (PMI®) Project Management Body Of Knowledge (PMBOK® Guide).

Prerequisite

No Prerequisite

Course Outcomes

On the successful completion of the course, students will be able to

CO 1.	Understand the importance of project management and the role of a project Manager.	Understand
CO 2.	Identify the critical path in scheduling a set of project-activities by using the Activity-On-Node method.	Apply
CO3.	Optimize resources of projects using scheduling, fast tracking and re-estimation techniques	Apply
CO 4.	Understand the importance and various activities performed for resource management, Outsourcing, risk assessment and project closure.	Understand
CO 5.	Apply the agile techniques for the project Management.	Understand

Mapping with Programme Outcomes

Cos	PO1	PO2	PO3	PO4	PO5	PO6	PO7	PO8	PO9	PO10	PO11	PO12
CO1.	-	-	-	-	-	S	-	S	S	M	S	S
CO2.	S	M	M	S	S	-	-	-	-	-	S	-
CO3.	S	M	L	-	S	L	-	-	-	-	S	L
CO4.	-	-	-	-	-	S	S	M	M	S	S	M
CO5.	-	-	-	-	-	S		M	S	L	S	M

S- Strong; M-Medium; L-Low

Assessment Pattern

Bloom's Category	Continuous Assessment Tests			Terminal Examination
	1	2	3	
Remember	20	20	20	20
Understand	50	50	50	50
Apply	30	30	30	30
Analyse	-	-	-	-
Evaluate	-	-	-	-
Create	-	-	-	-

Course Level Assessment Questions**Course Outcome 1 (CO1):**

1. Define a project. What are five characteristics that help differentiate projects from other functions carried out in the daily operations of the organization?
2. Suggest a suitable organisational structure for a Central Engineering Systems, Inc.
3. Explain about the roles of a project manager.

Course Outcome 2 (CO2):

1. Develop a work breakdown structure for a "Nuclear Generating Plant Project"
2. How does the WBS differ from the project network
3. Draw a project network from the following information. What activity(s) is a burst activity? What activity(s) is a merge activity?

ID	Description	Predecessor
A	Survey site	
B	Install drainage	A
C	Install power lines	A
D	Excavate site	B, C
E	Pour foundation	D

4. The table below defines the activities within a small project.

Activity	Completion time (weeks)	Immediate predecessor activities
A	2	-
B	3	-
C	4	A
D	3	B, A
E	8	D, C
F	3	C
G	2	E
H	3	F, G

- i. Draw the network diagram.
- ii. Calculate the minimum overall project completion time and identify which activities are critical.
- iii. What is the slack (float) time associated with each of the non-critical activities.

Course Outcome 3 (CO3):

1. How does resource scheduling reduce flexibility in managing projects?
2. Present six reasons scheduling resources is an important task.
3. Consider the following network diagram:

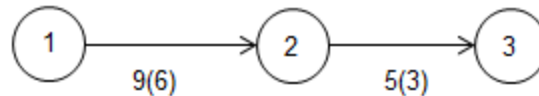

The following table gives the information about various activities of the above network.

Activity	Normal Duration (days)	Normal cost (Rs.)	Crash Duration (days)	Crash Cost (Rs.)
1 - 2	9	8000	6	9500
2 - 3	5	5000	3	5500

The project overhead costs are @ Rs.300.0 per day. Determine a) direct cost- duration relationship, b) total cost – duration relationship and the corresponding least cost plan(network).

4. With an illustrative example explain the resources smoothing method.

Course Outcome 4 (CO4):

1. How can outsourcing project work alleviate the three most common problems associated with multiproject resource scheduling?
2. What is the difference between avoiding a risk and accepting a risk?
3. What is the difference between mitigating a risk and contingency planning?

Course Outcome 5 (CO5):

1. What are the advantages of Agile PM? What are the disadvantages of Agile PM?
2. What similarities and differences exist between a traditional project manager and a Scrum master?
3. Why is it difficult to apply Agile PM to large scale projects?
4. Explain about the roles and functionalities of Stackholders.

Concept Map

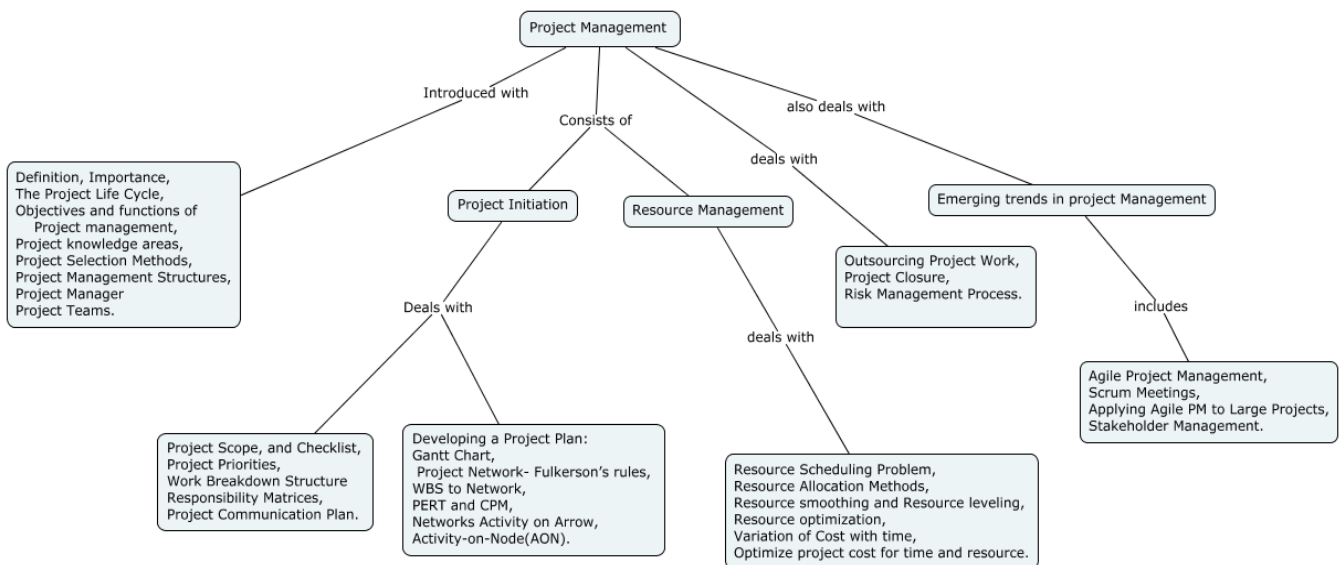

Syllabus

Project Management

Definition, Importance, Project Life Cycle, Objectives and functions of Project management, Project knowledge areas, Project Selection Methods, Project Management Structures, Organizing Projects within the Functional Organization, Matrix organisation, Project Manager – Roles, Responsibilities and Selection, Project Teams.

Project Initiation

Project Scope, and Checklist, Project Priorities, Work Breakdown Structure, Responsibility Matrices, Project Communication Plan. **Developing a Project Plan:** Gantt Chart, Project Network- Fulkerson's rules, WBS to Network, PERT and CPM, Networks Activity on Arrow, Activity-on-Node(AON).

Resource Management

Overview of the Resource Scheduling Problem, Types of Resource Constraints, Classification of a Scheduling Problem, Resource Allocation Methods- Resource smoothing and Resource leveling. **Resource optimization** Types of cost – Direct, Indirect and Total Cost. Variation of Cost with time. Schedule Compression Techniques- Crashing, Fast Tracking & Re-estimation- Crash time and crash cost. Optimize project cost for time and resource.

Outsourcing Project Work- The Art of Negotiating Managing Customer Relations, **Project Closure-** Types of Project Closure, Final Report, Post-Implementation Evaluation, **Managing Risk** - Risk Management Process, Risk Identification, Assessment, and Response Development.

Emerging trends in project Management: Agile Project Management, Scrum Meetings, Applying Agile PM to Large Projects. Stakeholder Management.

Text Book

1. Erik W. Larson, Clifford F. Gray, "Project Management The Managerial Process", McGraw-Hill/Irwin, Fifth Edition, 2011.
2. Punmia B. C. and Khandelwal K.K., "Project Planning and Control with PERT/CPM", Laxmi publications, New Delhi, 2011.

Reference Books

1. Jack R. Meredith, Samuel J. Mantel, Jr., "Project management A Managerial Approach", John Wiley & Sons, Inc. Seventh Edition, 2009
2. Harold Kerzner, "Project Management A systems approach to Planning, scheduling, And controlling", Tenth edition, John Wiley & Sons, Inc. 2009
3. Harold Kerzner, "Project management best practices achieving global excellence", Second edition, John Wiley & Sons, Inc. 2010
4. A Guide to the Project Management Body of Knowledge (PMBOK® Guide)—Fifth Edition, Project Management Institute.
5. Harold Koontz, Heinz Weihrich "Essentials of Management", Tata McGraw-Hill Education, 2006 - Management

Course Contents and Lecture Schedule

Module No.	Topic	No. of Lectures
1	Project Management	
1.1	Definition and its importance.	1
1.2	Project Life Cycle, Objectives and functions of Project management	2
1.3	Project knowledge areas	1
1.4	Project Selection Methods.	1
1.5	Project Management Structures,	1
1.6	Organizing Projects within the Functional Organization, Matrix organisation.	1
1.7	Project Manager – Roles, Responsibilities and Selection	1
1.8	Project Teams.	1
2	Project Initiation	
2.1	Project Scope, and Checklist, Project Priorities,	1
2.2	Work Breakdown Structure	1
2.3	Responsibility Matrices, Project Communication Plan.	1
2.4	Gantt Chart	1
2.5	Project Network- Fulkerson's rules	1
2.6	WBS to Network	1
2.7	PERT and CPM,	2
2.8	Networks Activity on Arrow, Activity-on-Node(AON).	2
3	Resource Management	
3.1	Overview of the Resource Scheduling Problem, Types of Resource Constraints, Classification of a Scheduling Problem	2

Module No.	Topic	No. of Lectures
3.2	Resource Allocation Methods- Resource smoothing and Resource leveling.	2
3.3	Resource optimization Types of cost – Direct, Indirect and Total Cost. Variation of Cost with time.	2
3.4	Schedule Compression Techniques- Crashing, Fast Tracking & Re-estimation- Crash time and crash cost. Optimize project cost for time and resource.	2
4	Outsourcing Project Work	
4.1	The Art of Negotiating Managing Customer Relations,	1
4.2	Project Closure - Types of Project Closure, Final Report, Post Implementation Evaluation	2
4.3	Managing Risk – Risk Management Process, Risk Identification, Assessment, and Response Development.	2
5	Emerging trends in project Management:	
5.1	Agile Project Management,	1
5.2	Scrum Meetings,	1
5.3	Applying Agile PM to Large Projects.	1
5.4	Stakeholder Management.	1
	Total	36

Course Designers:

- | | |
|---------------------------|------------------|
| 1. Mr. B.Praveen Kumar | bpkmech@tce.edu |
| 2. Mr.S.A.R.Sheik Masthan | sarsmech@tce.edu |

14MT720 UNMANNED AERIAL VEHICLE

Preamble

The course is concerned with the dynamics, modeling, simulation, testing and flying of unmanned aerial vehicles (UAVs). The focus is on the use of rapid prototyping software tools for vehicle modeling, guidance, navigation, and flight control, Real-time implementation, software-in-the-loop and hardware-in-the-loop simulation; and flight tests. Static and dynamic analysis of aircraft motion and Learn how to identify the basic mode of the vehicle dynamics Sensors/actuators/dynamics/control simulation Analyze the entire control system Classical and state space control approaches Multi-loop design techniques.

Prerequisite

14MT520 – Control system
 14MT340 –Thermal Engineering and Fluid Mechanics

Course Outcomes

On successful completion of the course, students will be able to

CO 1	Explain components and parts, fundamentals of aerodynamics	Remember
CO 2	Describe static stability and control	Understand
CO 3	Describe and derive flight dynamics and equation of motion	Understand
CO 4	Derive Quadrotor kinematics, dynamics and control equations	Apply

Mapping with Programme Outcomes

Cos	PO1	PO2	PO3	PO4	PO5	PO6	PO7	PO8	PO9	PO10	PO11	PO12
CO1	S	S	L		L					M		M
CO2	S	S	M	M	S					M		M
CO3	S	S	L	L	M					S		M
CO4	S	S	S	M	S		S			S		S

S- Strong; M-Medium; L-Low

Assessment Pattern

Bloom's Category	Continuous Assessment Tests			Terminal Examination
	1	2	3	
Remember	20	20	20	20
Understand	80	80	40	40
Apply	-	-	40	40
Analyse	-	-	-	-
Evaluate	-	-	-	-
Create	-	-	-	-

Course Level Assessment Questions

Course Outcome 1 (CO1):

1. Define Mach number and classify the different types of flow?
2. Derive Bernoulli's Equation for compressible fluid?
3. An altimeter set for sea-level standard pressure indicates an altitude of 20000ft. If the outside ambient temperature is -5°F , Find the air density and the density altitude.
4. A high Altitude, remotely piloted communications platform is flying at a pressure altitude of 60000 ft and an indicated airspeed of 160ft/s. The outside ambient temperature is -75°F . Estimate the Reynolds number of the wing based on a mean chord of 3.5ft.
5. Define Axial force, Side force, Normal force?

Course Outcome 2(CO2):

1. Define Longitudinal Static Stability?
2. Derive equation for Directional Control?
3. The differential equation for the constrained center of gravity pitching motion of an airplane is computed to be

$$\ddot{a} + 4\dot{a} + 36a$$

Find the following :

- (a) ω_n , natural frequency ,rad/s
 - (b) ξ , damping ratio
 - (c) ω_d damped natural frequency, rad/s
4. Given the second order differential equation

$$\ddot{\theta} + 2\dot{\theta} + 5\theta$$

- (a) Rewrite this equation in the state space form
 $\dot{x}=Ax+B\eta$
- (b) Determine the eigen values of A matrix

Course Outcome 3 (CO3):

1. Determine the longitudinal equation

$$\dot{x}=Ax+B\eta$$

For that VTOL vehicle

- (a) Determine the eigen values of the A matrix
 - (b) Determine the response of the airplane to a step input of the elevator $\Delta\delta_e=-0.1$ rad
2. A wind tunnel model free to rotate about its x-axis is spun up to 10.5 rad/s by means of a motor drive system, when the motor drive is disengaged, the model spin will decay as shown below, from the spin time history determine the roll damping derivative L_p .

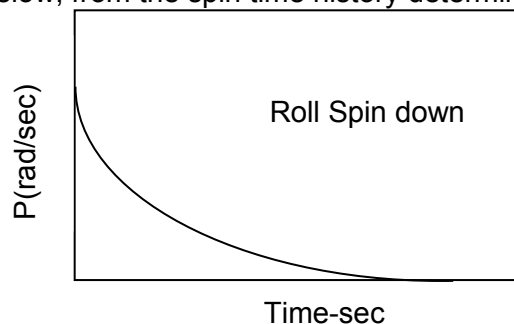

3. Rewrite the following differential equation in state-space form:

$$\frac{d^2c_1}{dt^2} + 5\frac{dc_1}{dt} + 4c_2 = r_1$$

$$\frac{dc_2}{dt^2} + \frac{dc_1}{dt} + c_1 + 3c_2 = r_2$$

4. Define Stability Augmentation?

Course Outcome 4 (CO4):

1. Derive quadrotor equations of motion.
2. Explain the procedure to select the motor for quadrotor.
3. Define reference frame.
4. Explain the component selection procedure with suitable example.

Concept Map

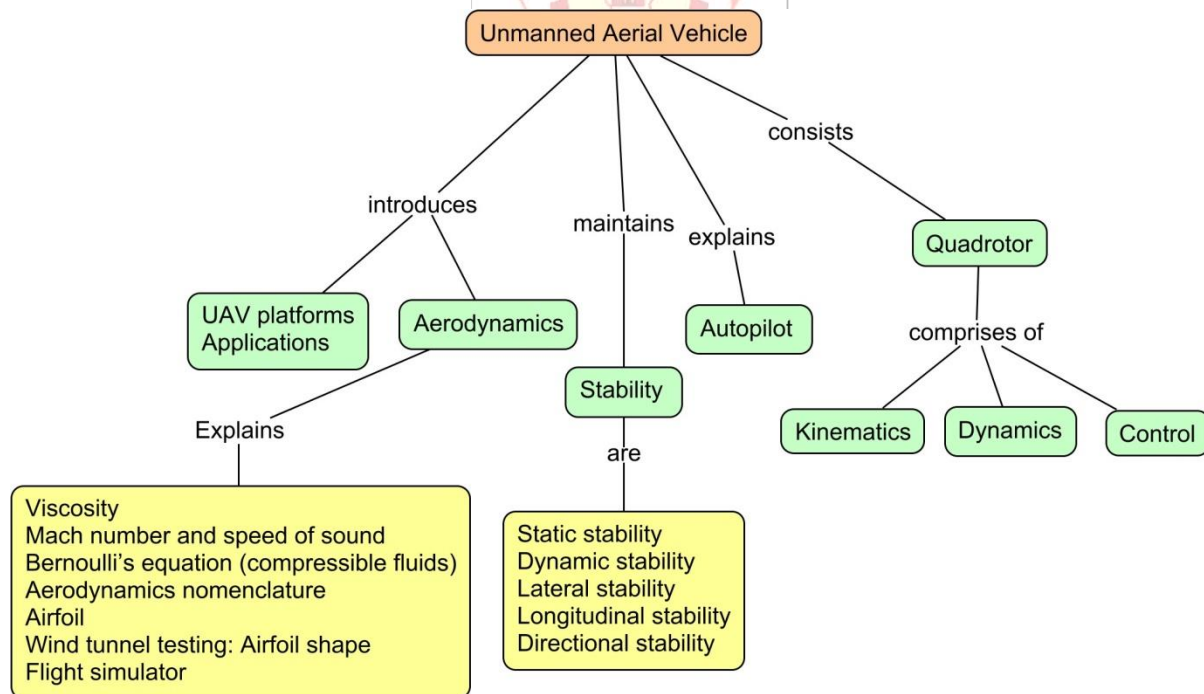

Syllabus

Unmanned aerial vehicle: Introduction, classification of UAV platform, applications

Fundamentals of aerodynamics: basic definitions: viscosity, Mach number and speed of sound, Bernoulli's equation (compressible fluids), aerodynamics nomenclature, airfoil, wind tunnel testing: airfoil shape, flight simulator

Static stability and Control: definitions, wing contribution, tail contribution, fuselage contribution. Longitudinal control: elevator effectiveness, elevator angle to trim, trim tab

Flight dynamics: Static stability, Dynamic stability, lateral stability, longitudinal stability, directional stability

Equations of motion: state space equations of longitudinal motion, lateral motion, Autopilot.

Quadrotor: key components of autonomous flight, state estimation, Basic mechanics, Dynamics of 1-D linear control, Design considerations, Agility and Maneuverability, component selection, effect of size.

Quadrotor Kinematics: Transformations, Rotations, Euler angles, Axis/angle representations for rotations, Angular velocity.

Quadrotor Dynamics: Formulation, Newton-euler equations, principal axes and principal moments of inertia, quadrotor equations of motion

Control: 2D control, 3D control

Text Books

6. Robert C Nelson, “ **Flight stability and Automatic Control**”, second edition, Tata McGraw-Hill, Special Indian Edition 2007.
7. Kenzo Nonami et. Al., “**Autonomous Flying Robots Unmanned Aerial Vehicles and Micro Aerial Vehicles**”, Springer, 2010.

Reference Books

8. Thanh Mung Lam, “**Aerial vehicles**”, In-Tech, 2009
9. Rogelio Lozano, “**Unmanned Aerial vehicles Embedded Control**”, ISTE Ltd, 2010.

Course Contents and Lecture Schedule

Module No.	Topic	No. of Lectures
1	Unmanned aerial vehicle	
1.1	Introduction	1
1.2	Classification of UAV platform, Applications	2
2	Fundamentals of aerodynamics	
2.1	Basic definitions: viscosity, Mach number and speed of sound	2
2.2	Bernoulli's equation (compressible fluids)	1
2.3	Aerodynamics nomenclature, Airfoil, wind tunnel testing: airfoil shape	2
2.4	Flight simulator	2

Module No.	Topic	No. of Lectures
3	Static stability and Control	
3.1	Definitions, wing contribution, tail contribution	2
3.2	Fuselage contribution, longitudinal control: elevator effectiveness	2
3.3	Elevator angle to trim, trim tab	2
4	Flight dynamics	
4.1	Static stability, Dynamic stability	2
4.2	Lateral stability, longitudinal stability, Directional stability	2
5	Equations of motion	
5.1	State space equations of longitudinal motion, lateral motion, Autopilot.	2
6	Quadrotor	
6.1	key components of autonomous flight, state estimation	2
6.2	Basic mechanics, Dynamics of 1-D linear control	2
6.3	Design considerations, Agility and Maneuverability, component selection, effect of size.	2
7	Quadrotor Kinematics	
7.1	Transformations, Rotations, Euler angles, Axis/angle representations for rotations, Angular velocity.	2
8	Quadrotor Dynamics	
8.1	Formulation, Newton-euler equations, principal axes and principal moments of inertia	2
8.2	Quadrotor equations of motion	2
9	Control	
9.1	2D control, 3D control	2
Total Hours		36

Course Designers:

Mr T Vivek

- tvivek@tce.edu

Ms S. Siva Priya

- ssmect@tce.edu

14MT770**SYSTEM INTEGRATION**

Category	L	T	P	Credit
PC	3	0	2	4

Preamble

Mechatronics has been an emerging subject in industry with the introduction of a large volume of mechatronics product to the market, ranging from the large scale products such as hybrid/electric cars, industrial robots and CNC machines, to the smaller consumer products such as digital cameras, DVD players, and programmable sewing machines. Mechatronics design involves integrating design of various domains by encompassing knowledge of mechanical engineering, electrical/electronics engineering, and information Technology.

Cross-disciplinary integration of mechanical engineering, electrical and electronic engineering as well as recent advances in information engineering are becoming more and more crucial for future collaborative design, manufacture, and maintenance of a wide range of engineering products and processes. This course gives insight in to the integration of sensors and actuators with controller through communication networks in order to realize the new product and total automated system.

Prerequisite

- 14MT230-Electrical Machines
- 14MT330-Sensors and PLC
- 14MT450-Fluid power automation
- 14MT570-Microcontrollers

Course Outcomes

On successful completion of the course, students will be able to

CO1.	Describe the characteristics and function of sensors, actuators and controllers.	Remember
CO2.	Interface sensor, actuator and controller with suitable driver.	Understand
CO3.	Select a suitable sensor and actuator for Mechatronics system integration	Apply
CO4.	Develop a controller program to integrate all Mechatronics components using communication network.	Apply

Mapping with Programme Outcomes

Cos	PO1	PO2	PO3	PO4	PO5	PO6	PO7	PO8	PO9	PO10	PO11	PO12
CO1.	M	M	M	S	M	M	-	M	M	-	-	S
CO2.	M	M	S	S	M	M	-	M	S	S	M	S
CO3.	S	S	S	S	S	S	S	S	S	S	M	S
CO4.	M	M	S	S	M	M	-	M	S	S	M	S

S- Strong; M-Medium; L-Low

Assessment Pattern

Theory (70 marks)				Practical (30 marks)		
Bloom's Category	Continuous Assessment Tests (20)		Terminal Examination (50)	Valuation category	Continuous Assessment (10)	Continuous Assessment Test 3 (20)
	1	2				
Remember	20	20	20	Class work/ Exercise	90	90
Understand	20	20	20	Record / Viva-voce	10	10
Apply	60	60	60			
Analyse	0	0	0			
Evaluate	0	0	0			
Create	0	0	0			

Theory Cum Practical Courses:

There shall be three tests: the first two tests (Maximum 50 marks for each test) will be from theory component and the third test (Maximum 50 Marks) will be for practical component. The sum of marks of first two tests shall be reduced to 20 Marks and the third test mark shall be reduced to 20 marks. Average mark awarded for viva – voce, conduct of experiments, observation & results, record work in regular class works shall be reduced to 10 marks. The sum of these 50 Marks would be rounded to the nearest integer.

Course Level Assessment Questions**Course Outcome 1 (CO1):**

1. List the types of proximity sensors.
2. Explain the I/O Modules of PLC.
3. Explain the components of SCADA System.
4. Explain the function of ultrasonic sensor.

Course Outcome 2 (CO2):

1. Explain the Geared DC motor interfacing with PLC.
2. List the types of directional control valves available in fluidic systems.
3. Explain the V/F method of speed control in Induction motor drive.
4. Write a PLC program to control the speed of the induction motor using PLC and VFD drive.

Course Outcome 3 (CO3):

1. Explain the each layer of Open System Interconnection model.
2. Illustrate the Control Area Network with frame format.
3. Compare the standard Ethernet, Fast Ethernet and Gigabit Ethernet.
4. Explain the GSM network architecture.
5. Explain the functional areas of IEEE 802.11 medium access control.

Course Outcome 4 (CO4):

1. Design a PLC program to interface servo drive in Master Slave Mode.
2. Design a controller program to interface dc geared motor and proximity sensor for conveyor system
3. Design a PLC ,HMI program to develop a object sorting system
4. Develop a controller program to interface sensors and actuators through communication bus.

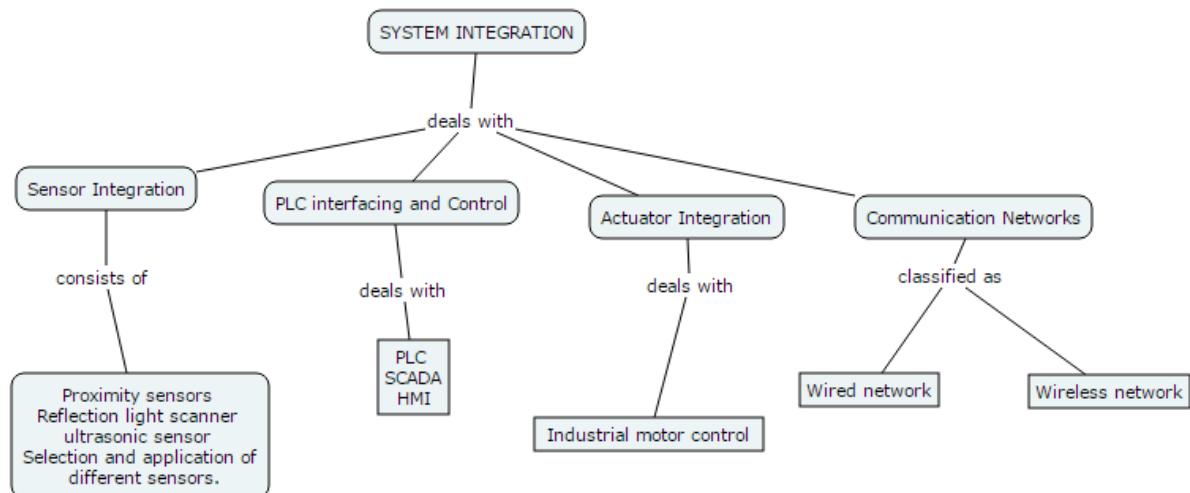
Concept Map**Syllabus****Sensor Integration**

Proximity sensors – inductive, capacitive, magnetic field - reflection light scanner – ultrasonic sensor (switching distance, hysteresis, reduction factor and response curve of sensors), IR sensor-Motion sensors-Torque sensor-Selection and wiring of different sensors.

PLC interfacing and Control

Design of Electrical control diagram-Electrical control components-Selection of controllers-features- arduino, raspberry pi, ARM-Drivers requirement -Selection of PLC-PLC input Module-Wiring Diagram, Interfacing issues-Interfacing of sensors, current sourcing and sinking concept-Interfacing Input devices with PLC-Output Module-Wiring Diagram, Interfacing output devices – Interfacing HMI and SCADA with PLC-Connecting PLC's in Master Slave mode –Interfacing PLC with Hydraulic and Pneumatic systems-Advanced PLC functions.

Actuator Integration

Geared DC motor Interfacing ,creating a hydraulic and pneumatic circuits using PLC,Programming VFD, Interfacing VFD –Servo programming-Programming a motion

sequence in virtual and real axis-Recording Motion of both axes-Creating a Flex profile via PLC- Robot control programming-Servo Master/Slave concept-Servo programming for feed drive.

Communication Networks

Network Fundamentals: Network types - Network Models Network protocols: token bus, token ring, medium access control, CAN, FDDI, I2C, and PCI Wired network: Ethernet, Profibus, Profinet, Sercos Wireless network: GSM, zigbee, Bluetooth, wireless LAN medium access layer

List of Experiment

1. Behaviour of inductive and capacitive sensors
2. Behaviour of magnetic field sensors
3. Behaviour of reflection light scanner
4. Behaviour of ultrasonic sensors
5. Develop a controller based object sorting system by selecting and placing suitable sensor and actuator in a conveyor.
6. Develop a feed drive system using linear slide, servo drive and Encoder, and control the motion (Position, Velocity, and Acceleration) of feed drive using suitable controller.
7. Design a Industrial level control system by fabricating suitable container, placing proper sensor and actuator, and controlling and Monitoring the same using PLC,HMI and SCADA.
8. Programming and Controlling Servo drive in Master –Slave mode using PLC for Industrial Robot Control.
9. Design a Plant graphics in SCADA for monitoring and controlling the plant parameters (Machine control, Process Parameters control, Energy control)
10. Design a cooling fan system in which the speed of the fan need to be controlled by VFD depending on the temperature of a system.
11. Sequential operation of Hydraulic cylinders using the concept of IOT.
12. Design a Industrial Communication networks using Profibus, Profinet, Ethernet and Sercos for the integration of mechatronics system.

Text Book

1. Frank D petruzella, "**Programmable logic controllers**",Fourth edition,McGraw Hill higher education ,2016
2. Frank D petruzella, "**Electrical Motor and control systems**", McGraw Hill higher education ,2010

Reference Books

1. Krishna Kant –"**Computer Based Industrial Control**", EEE-PHI, 2nd edition, 2010.
2. Garry Dunning-**Introduction to Programmable Logic Controllers**, 2nd edition, Thomson, ISBN: 981-240-625-5.
3. W.Bolton- **Programmable Logic Controllers**, Sixth Edition (Paperback) ISBN-13: 978-0128029299, 2012.

4. Steve Mackay ,Edwin Wright MIPENZ, Deon Reynders, John Park **“Practical Industrial Data Networks -Design, Installation, trouble shooting”** ,IDC Technologies, Australia.
5. **“System development automation motion logic control”** published by Bosch Rexroth.
6. **“Data communication and networking”**,5 th edition B. Forouzan McGraw Hill higher education ,2013

Course Contents and Lecture Schedule

Sl.No.	Topic	No. of Lectures
1.0	Sensor Integration	
1.1	Proximity sensors – inductive, capacitive, magnetic field	2
1.2	reflection light scanner, ultrasonic sensor	1
1.3	Motion sensors, Torque sensor	2
1.4	Selection and wiring of different sensors- current sourcing and sinking concept	1
2.0	PLC interfacing and Control	
2.1	Design of Electrical control diagram	1
2.2	Electrical control components-	1
2.3	Selection of controllers-features- arduino, raspberry pi, ARM-Drivers requirement	2
2.3	Selection of PLC -PLC input Module-Wiring Diagram, Interfacing issues	1
2.4	Interfacing of sensors-Current sourcing and sinking concept.	1
2.5	Interfacing Input devices with PLC-Output Module-Wiring Diagram	1
2.6	Interfacing output devices –Interfacing HMI and SCADA with PLC	2
2.7	Connecting PLC's in Master Slave mode	1
2.9	Interfacing PLC with Hydraulic and Pneumatic systems-Advanced PLC functions.	2
3.0	Actuator Integration	
3.1	Geared DC motor Interfacing ,creating a hydraulic and pneumatic circuits using PLC	2
3.2	Programming VFD, Interfacing VFD	2
3.3	Servo programming-Programming a motion sequence in virtual and real axis	1
3.4	Robot control programming-Servo Master/Slave concept	2
3.5	Basics of SCADA system-SCADA key features	1

Sl.No.	Topic	No. of Lectures
3.6	Servo programming for feed drive	1
4.0	Communication Network	
4.1	Network Fundamentals: Network types - Network Models	2
4.2	Network protocols: token bus, token ring, medium access control	1
4.3	CAN, FDDI, I2C and PCI	2
4.4	Wired network: Ethernet, Profibus, Profinet, Sercos	2
4.5	Wireless network: GSM, zigbee	1
4.6	Bluetooth, wireless LAN medium access layer	1
TOTAL		36

Course Designers

1. T.Vivek
2. H.Ramesh
3. A.Prakash



tvivek@tce.edu
rameshh@tce.edu
apmech@tce.edu

14MT7C0

CAPSTONE COURSE II

Preamble

The purpose of this course is to apply the concept of mathematics, science and engineering fundamentals and an engineering specialization to solve complex engineering problems.

Syllabus

1. Engineering Group – 1

a. Fluid Mechanics:

Fluid properties – Pressure, Density, Specific gravity, Viscosity, Surface tension, Capillarity, Compressibility and Bulk Modulus. Fluid statics-Manometry. Fluid kinematics- types of flow. Fluid Dynamics - Bernoulli's Equation.

b. Thermodynamics:

Thermodynamic system, Properties, Zeroth, First Law of thermodynamics: Types of work transfer and modes of heat transfer. Second law of thermodynamics.

c. Manufacturing process

Casting- Different types of casting, design of patterns, moulds and cores. Sheet metal forming process- Shearing, Bending and Deep drawing. Metal forming processes- Rolling, Forging, Extrusion and Drawing. Metal joining processes - Principles of welding, brazing and soldering. Non conventional machining processes

d. Metrology and Inspection:

Comparators

e. Fluid power

Direction flow and pressure control valves -Directional control valve – 3/2 way valve – 4/2 way valve – 5/2 way valve . Shuttle valve – check valve. Pressure control valve – Simple and compound relief valve, pressure reducing valve, sequence valve, counter balance valve.

2. Engineering group – 2

a. Electrical

Differential Equations of a Physical system- Developing transfer function of a physical system- Type of the system-Types of input-Time Domain Specifications-Step response of a 1st and 2nd order system-Static and dynamic error co-efficients-Routh Hurwitz stability criterion-Root locus method-Frequency response methods-Bode plot, Polar plot, Nyquist criterion-Lead, Lag, Lead-Lag compensator design, PID controller design.

Power Devices-SCR,MOSFET,IGBT –Controlled rectifier DC Drives-Chopper controlled DC drives-Inverter fed AC drives- Special Machine drives-SRM, Stepper, Servo-Power Supply-Types-UPS-Batteries.

8051 micro controller architecture-instruction sets-Addressing modes-Assembly level program-Timers, UART programming, ADC, DAC, LCD interfacing-Embedded C programming

b. Analog Electronics

Characteristics and applications of diode, Zener diode, BJT and MOSFET; small signal analysis of transistor circuits, feedback amplifiers. Characteristics of operational amplifiers; applications of opamps: difference amplifier, adder, subtractor, integrator, differentiator,

instrumentation amplifier, precision rectifier, active filters and other circuits. Oscillators, signal generators, voltage controlled oscillators and phase locked loop.

c. Digital Electronics

Combinational logic circuits, minimization of Boolean functions. IC families: TTL and CMOS. Arithmetic circuits, comparators, Schmitt trigger, multi-vibrators, sequential circuits, flip-flops, shift registers, timers and counters; sample-and-hold circuit, multiplexer, analog-to digital (successive approximation, integrating, flash and sigma-delta) and digital-to analog converters (weighted R, R-2R ladder and current steering logic). Characteristics of ADC and DAC (resolution, quantization, significant bits, conversion/settling time); basics of number systems, 8-bit microprocessor and microcontroller: applications, memory and input-output interfacing; basics of data acquisition systems.

d. Measurement and Sensors

Resistive, capacitive, inductive, piezoelectric, Hall effect sensors and associated signal conditioning circuits; transducers for industrial instrumentation: displacement (linear and angular), velocity, acceleration, force, torque, vibration, shock, pressure (including low pressure), flow (differential pressure, variable area, electromagnetic, ultrasonic, turbine and open channel flow meters) temperature (thermocouple, bolometer, RTD (3/4 wire), thermistor, pyrometer and semiconductor); liquid level, pH, conductivity and viscosity measurement.

Reference Books

1. Yunus A. Cengel and Michael A. Boles, "**Thermodynamics: An Engineering Approach**", 7th Edition, McGraw Hill Education (India) Private Ltd., 2011.
2. Bruce R. Munson, Theodore H. Okiishi, Wade W. Huebsch, Rothmayer, "**Fluid Mechanics**", Seventh Edition, Wiley India Pvt. Ltd, 2015.
3. Serope Kalpakjian and Steven R.Schmid, "**Manufacturing Engineering and Technology**", Sixth Edition, PHI, 2010.
4. Mikell P.Groover "**Fundamental of Modern Manufacturing**", Wiley India Edition, Third Edition, Reprint, 2012.
5. Anand K Bewoor and Vinay A Kulkarni "Metrology and Measurement" Tata McGraw Hill Edition, 2009.
6. Anthony Esposito ,Fluid Power with Applications, Prentice-Hall, 2009
7. Richard C. Dorf, Robert H. Bishop, "**Modern Control Systems**" Twelfth Edition, Pearson Education, 2014.
8. Katsuhiko Ogata,"**Control System Engineering**" second edition, Pearson Education Asia Private Ltd, 2002.
9. Katsuhiko Ogata,"**Discrete-Time Control Systems**" second edition, Pearson Education Asia, 2002.
10. Ramakant Gayakwad, "Op-amps and Linear Integrated Circuits", 4th Edition, Prentice Hall,2000.
11. Robert, F., Coughlin, Frederick F., Driscoll, "Operational Amplifiers and Linear Integrated Circuits", 5th Edition, Prentice Hall, 1998.
12. Morris Mano, M. and Michael D. Ciletti, "Digital Design with an Introduction to the Verilog HDL", 5th Edition, Prentice Hall, 2013.
13. Donald P Leach, Albert Paul Malvino and Goutam Saha, "Digital Principles and Applications", 8th Edition, McGraw-Hill, 2014.
14. Doebelin E.O. and Manik D.N., "Measurement Systems", 6th Edition, Tata McGraw-Hill Education Pvt. Ltd., 2011.
15. John P. Bentley, " Principle of measurement systems", Pearson education, Prentice Hall publication, 2004, 4th edition.
16. S.Renganathan, "Transducer Engineering", Allied publishers, New Delhi 2003.
17. Patranabis, D., "Sensors and Transducers", 2nd Edition, Prentice Hall of India, 2010.

Assessment pattern**(Common to B.E./B.Tech Programmes)****I. Comprehensive Test****Test 1: Engineering Group 1(60 Marks)****Duration: 90minutes**

Objective Type Questions : 30

Fill in the blanks type questions : 30

Test 2: Engineering Group 2 (60 Marks)**Duration: 90minutes**

Objective Type Questions : 30

Fill in the blanks type questions : 30

II. Complex Engineering Problem Solving (60 Marks):

- Selection of a complex engineering problem (Batch size: 2-4) : 5 Marks
- Literature Survey : 5 Marks
- Problem Formulation : 5 Marks
- Solution Methodology : 10 Marks
- Results and Discussion : 15 Marks
- Technical Report : 10 Marks

Final Mark consolidation

Test	Maximum Marks	Converted to (Marks)
Test 1	60	20
Test 2	60	20
Review 1	60	20
Review 2	60	30
Technical Report	10	10
Total		100

Note: No re-test will be conducted at any circumstances for comprehensive test.**Rubrics for Review 1**

- Selection of a complex engineering problem
- Literature Survey
- Problem Formulation

Rubrics for Review 2

- Solution Methodology
- Results and Discussion

Technical Report

- Each batch of students should submit a technical report before last working day

Course Designers

- | | |
|-----------------------|--------------------|
| 1. Dr. L.R. Karl Marx | lrkarlmarx@tce.edu |
| 2. Mr. H. Ramesh | rameshh@tce.edu |
| 3. Ms. T.R.Viveki | trvmect@tce.edu |

Preamble

Machine Vision (MV) is industry application oriented subset of computer vision. It is the study of methods and techniques whereby artificial vision systems can be constructed and usefully employed in manufacturing applications. Machine vision integrates image capture systems with digital input/output devices and computer networks to provide real time quality control and for general control of manufacturing equipment such as automated assembly systems and robotic manipulator. Manufacturers accept machine vision systems due to its high-speed, high-magnification, 24-hour operation, and/or repeatability of measurements for visual inspection applications.

Machine Vision (MV) systems can be applied in almost any industry. Historically the first systems were deployed in the semi-conductor and automotive industries due to their highly intensive use of industrial automation within these industries. Modern vision systems can be applied across a hugely diverse range of industry sectors, these industries include: Automotive, Semi-conductor, Electronics, Medical Devices and Pharmaceutical, Printing and Packaging, Food Processing, Solar Production and Process Engineering.

Prerequisite

- Nil

Course Outcomes

On the successful completion of the course, students will be able to

CO1.	Explain the components of a machine vision system and their functions	Understand
CO2.	Select the appropriate sensor and illumination techniques of machine vision system for the given manufacturing application	Apply
CO3.	Select suitable image processing technique for the specified manufacturing requirement	Apply
CO4.	Select suitable components of machine vision system for the given manufacturing applications such as part identification, counting, measurement and gauging	Apply

Mapping with Programme Outcomes

COs	PO1	PO2	PO3	PO4	PO5	PO6	PO7	PO8	PO9	PO10	PO11	PO12
CO1.	L	L	-	-	-	-	-	-	-	-	-	-
CO2.	S	M	M	-	-	-	L	-	-	M	-	-
CO3.	S	M	M	-	-	-	L	-	-	M	-	-
CO4.	S	M	M	-	-	-	L	-	-	M	-	-

S- Strong; M-Medium; L-Low

Assessment Pattern

Bloom's Category	Continuous Assessment Tests			Terminal Examination
	1	2	3	
Remember	20	10	-	10
Understand	40	30	40	30
Apply	40	60	60	60
Analyse	-	-	-	-
Evaluate	-	-	-	-
Create	-	-	-	-

Course Level Assessment Questions

Course Outcome 1 (CO1):

1. With suitable block diagram, explain the components of a machine vision system.
2. How digital images are produced using CCD camera?
3. Explain the operation of image acquisition system and its functions.
4. Explain the flow of information between the components of a machine vision system.

Course Outcome 2 (CO2):

1. Suggest suitable sensor and illumination techniques required for a palletizing operation in a manufacturing cell where the robot must pick up the parts from an incoming chute and deposit them onto pallet. The pallet has four rows that are 50 mm apart and six columns that are 40 mm apart. The plane of the pallet is assumed to be parallel to XY plane. The rows of the pallet are parallel to the X-axis and the columns of the pallet are parallel to the Y-axis. The objects to be picked up are about 25 mm tall. Suggest suitable actions to be taken and show the step by step procedure for the implementation of robotized palletizing operation. Make judicious assumptions if required and justify them.
2. In the production of floating bearings, the bearing and the shafts are riveted. Due to material and processing influences, the diameter of the rivet needs to be inspected. Every rivet has to be checked as shown in figure.

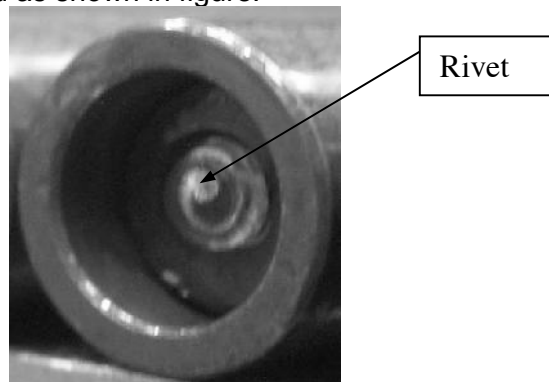

The diameters of two similar rivets have to be inspected; the task can be categorized into a measurement application. The nominal size of the rivets lies in a range of 3 mm to 4 mm; it is placed in front of a disk. The surface color of the disk might change due to material changes. The rivet material does not change. The bearings can be covered with an oil film. The 100% inspection of every part has to be performed inline. The nominal size of the rivet is 3.5 mm, and the required accuracy is 0.1 mm. The inspection used to be performed manually. The diameter of the rivet needs to be measured with an accuracy of 0.1 mm. The processing result has to be presented immediately. The maximum processing time is 2 s; the cycle time is 2.5s. A direct insight into the rivet is

possible. The maximum space for installing equipment is 500 mm. The distance between the cameras and the computer is 5 m. A certain protection class is not necessary. Propose suitable image acquisition technique for this application.

Course Outcome 3 (CO3):

2. Discuss the effect of sampling rate and the quantization on the images of size: 432x576, 108x144, 54x72 and 27x36.
5. With suitable example, explain the use of binary morphology operations in a vision based sorting application.
6. Describe the steps involved in recognising the objects (spanners with different orientations) from a captured image by an acquisition system as shown in figure.1. Also, suggest the method of measuring dimensions of the object.

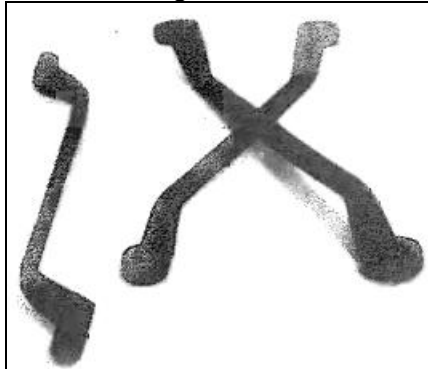

Figure. 1

Course Outcome 4 (CO4):

1. Design a machine vision system to measure the dimensions of the threaded part moving in a slow speed conveyor as shown in figure 2.

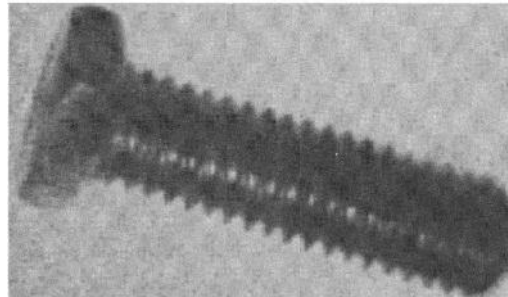

Figure 2

3. Suggest a suitable machine vision system to segregate the components shown in figure 3. Make judicious assumptions if required and justify them.

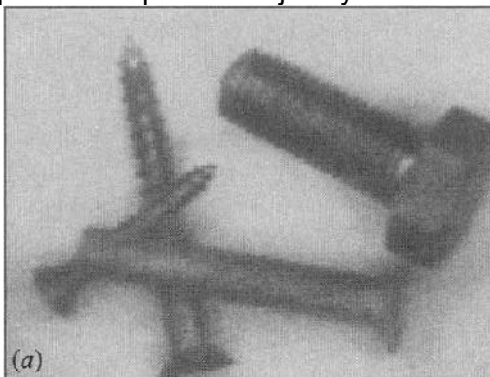
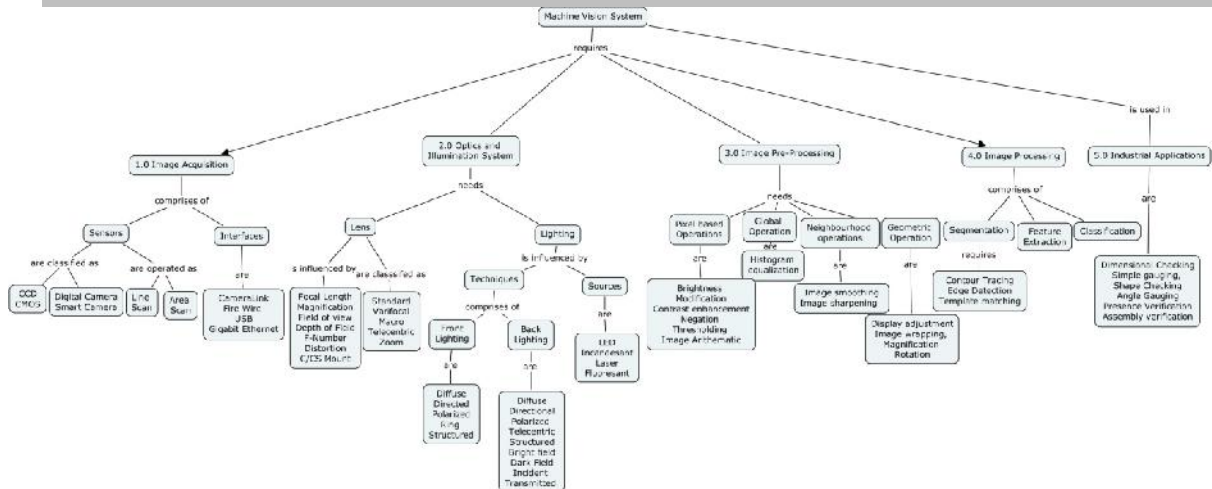

Figure 3

Concept Map



Syllabus

Image Acquisition: Solid State Sensors – Operation of Charge Coupled Device (CCD) and Complementary Metal Oxide Semiconductor (CMOS) Sensors – Colour Sensors – Properties of Sensors. Digital cameras – control of image capture – Characteristic values – industrial operating conditions. Control of Line Scan and Area scan cameras. Image Data Transfer – Digital Camera Interfaces – CameraLink, Fire Wire, USB and Gigabit Ethernet.

Optics and Illumination: Optical foundations: Focal length, Magnification, Field of view, Depth of field, F number, Distortion. Thin Lens, Imaging Equation, Typical Imaging Situations, Aberrations, Lens Selection – Mounts, Telecentric lens, Fisheye lenses and endoscopes. Light Sources - Types of Light Filters, Types of Lighting: Front lighting – Diffuse, Directed, Polarized, Ring and Structured; Back lighting – Diffuse, Directional, polarized Telecentric, Structured, Bright field, Dark Field, Incident and Transmitted Lighting.

Image Pre-processing (Spatial domain): Gray Scale Transformations: Point operation – brightness modification, Contrast enhancement, and thresholding. Image Arithmetic: Image Addition, Subtraction and Averaging, Minimum and Maximum of two images. Global operation – Histogram equalization. Neighbourhood operation – Image smoothing and image sharpening - Types of Filters: Linear Filters, Median Filter, Morphological and Non Linear Filters. Regions of Interests (ROIs) - Threshold Determination from Histogram, Pixel connectedness, Contour Tracing - Edge Detection, Template matching: Operation.

Image Processing: Segmentation: Regions of Interests (ROIs) - Threshold Determination from Histogram, Contour Tracing: Pixel connectedness, Generating Object Contours, Contour representation, Edge based Methods: Edge probing and Edge Detection, Template matching: Operation. **Feature Extraction:** Geometric features – Enclosing rectangle, area, perimeter and centroid. **Classification:** Nearest Neighbour classifier.

Applications: Dimensional Checking: Simple gauging, Shape Checking, Angle Gauging, High accuracy Gauging, Calibration. Presence Verification: Simple Presence verification, Simple Gauging for assembly verification such as Pin type Verification. Decision making and actuation on visual signals - Case Studies – Currency verification – Pharmaceutical industry.

Text Book

1. Christian Demant, Bernd Streicher-Abel, Carsten Garnica “**Industrial Image Processing - Visual Quality Control in Manufacturing**”, Second Edition, Springer, 2013.

Reference Books/Learning Resources

1. R.C. Gonzalez, Richard E. Woods, “**Digital Image Processing**” Second Edition, Prentice Hall India, 2005.
2. K.S. Fu, R.C. Gonzalez, C.S.G. Lee “**Robotics Control, Sensing, Vision and Intelligence**” Tata McgrawHill, 2008

3. Alexander Hornberg, “**Handbook of Machine Vision**”, Wiley VCH, 2006
4. Gerald C. Holst, “**CCD Arrays Cameras and Displays**” Second Edition, SPIE Optical Engineering Press, 1998.
5. Elias N. Malamas, Euripides G.M. Petrakis, Michalis Zervakis, Laurent Petit, Jean-Didier Legat, “**A survey on industrial vision systems, applications and tools**”, Image and Vision Computing 21 (2003) 171–188.
6. H. Golnabi, A. Asadpour, “**Design and application of industrial machine vision systems**”, Robotics and Computer-Integrated Manufacturing 23 (2007) 630–637.

Course Contents and Lecture Schedule

Module No.	Topic	No. of Lectures
1.	Image Acquisition	
1.1	Solid State Sensors – Introduction	1
1.1.1	Operation of Charge Coupled Device (CCD) sensor	1
1.1.2	Operation of Complementary Metal Oxide Semiconductor (CMOS) Sensors	1
1.1.3	Operation of Color Sensors - Properties of Sensors	1
1.1.4	Digital cameras – control of image capture – Characteristic values – industrial operating conditions.	1
1.1.5	Smart cameras – control of image capture	1
1.1.6	Control of Line Scan and Area scan cameras	1
1.2	Image Data Transfer – Digital Camera Interfaces - CameraLink, Fire Wire, USB and Gigabit Ethernet.	1
2.	Optics and Illumination	
2.1	Optical foundations: Depth of field, Field of view and focal point	1
2.1.1	F number, Thin Lens, Imaging Equation	1
2.1.2	Typical Imaging Situations, Aberrations	1
2.1.3	Lens Selection – Mounts, Telecentric lens, Fisheye lenses and endoscopes	1
2.2	Light Sources, Types of Light Filters	1
2.2.1	Types of Lighting: Front lighting – Diffuse, Directed, Polarized, Ring and Structured	1
2.2.2	Back lighting – Diffuse, Directional, polarized Telecentric, Structured, Bright field, Dark Field, Incident and Transmitted Lighting.	1
3.	Image Pre-processing	
3.1	Gray Scale Transformations - Point operation – brightness modification, Contrast enhancement, and thresholding	1
3.1.1	Image Arithmetic: Image Addition, Subtraction and Averaging, Minimum and Maximum of two images.	1
3.2	Global operation – Histogram equalization	1
3.3	Neighbourhood operation – Image smoothing and image sharpening	1
3.3.1	Types of Filters: Linear Filters, Median Filter, Morphological and Non Linear Filters.	1
3.4	Geometric operation – Display adjustment, image wrapping, magnification and rotation.	1
4.	Image Processing	
4.1	Segmentation: Regions of Interests (ROIs) - Threshold Determination from Histogram	1
4.1.1	Contour Tracing: Pixel Connectedness, Generating Object	2

Module No.	Topic	No. of Lectures
	Contours, Contour representation	
4.1.2	Edge based Methods: Edge probing and Edge Detection	2
4.1.3	Template matching: Operation	1
4.2	Feature Extraction: Geometric features – Enclosing rectangle, area, perimeter and centroid.	1
4.3	Classification: Nearest Neighbour classifier	1
5.	Applications	
5.1	Dimensional Checking: Simple gauging, Shape Checking, Angle Gauging	2
5.1.1	High accuracy Gauging – Calibration	1
5.2	Presence Verification: Simple Presence verification, Simple Gauging for assembly verification such as Pin type Verification	1
5.2.1	Decision making and actuation on visual signals	1
5.3	Case Studies – Seminars - Currency verification – Pharmaceutical industry	2
	Total	36

Course Designers:

- | | | |
|----|-------------------------|-------------------|
| 1. | Dr. C. Muruganantham | anathamcm@tce.edu |
| 2. | Dr. S.Saravana Perumaal | sspmech@tce.edu |

Preamble

Micro Electro Mechanical System (MEMS) contains components of sizes less than 1 millimetre. MEMS achieve some engineering functions by electro mechanical or electro chemical means. In general a sensor, an actuator and a signal transduction unit forms the MEMS device. Automobile, Aerospace, Health care are some of the areas where MEMS found applications. Natural science, Mechanical, Electrical, Chemical, Materials and Industrial Engineering are the disciplines involved in design, Manufacture and Packaging of MEMS devices. This course provides a comprehensive treatment with synergetic integration of wide spectrum of discipline in science and engineering to cater the multidisciplinary nature of Mechatronics.

Prerequisite

- Nil

Course Outcome

After successful completion of the course the student will be able to

CO1.	Explain the working principles of MEMS and Microsystems	Understand
CO2.	Solve problems in scaling laws applicable to miniaturization.	Apply
CO3.	Explain Materials for MEMS and Microsystems	Understand
CO4.	Select micro-system fabrication and Micro-manufacturing process for a given application	Apply
CO5.	Explain the packaging aspects of Micro System	Understand

Mapping with Programme Outcomes

COs	PO1	PO2	PO3	PO4	PO5	PO6	PO7	PO8	PO9	PO10	PO11	PO12
CO1.	S	L	M	S	L	-	-	-	-	M	L	L
CO2.	S	L	M	S	L	-	-	-	-	M	L	L
CO3	S	S	M	S	L	-	-	-	-	M	L	L
CO4	S	S	M	S	L	-	-	-	-	M	L	L
CO5.	S	L	M	S	L	-	-	-	-	M	L	L

S- Strong; M-Medium; L-Low

Assessment Pattern

Bloom's Category	Continuous Assessment Tests			Terminal Examination
	1	2	3	
Remember	20	20	20	20
Understand	50	50	50	50
Apply	30	30	30	30
Analyse	-	-	-	-
Evaluate	-	-	-	-
Create	-	-	-	-

Course Level Assessment Questions

Course Outcome 1 (CO1):

1. Distinguish microelectronics from MEMS.
2. Define the term MEMS.
3. Define shape memory alloys.
4. Write note on the advantages of miniaturization.
5. Explain in detail the application of MEMS in automobile industry.
6. With neat diagram explain the functioning of micro pressure sensor.

Course Outcome 2 (CO2):

1. Record two types of scaling laws used in micro-systems.
2. Write the scaling formula for a simple rectangular block.
3. Explain in detail, the Trimmer matrix to represent force scaling with related acceleration, time and power density required for scaling of systems in motion.
4. Give a report on scaling in heat conduction and heat convection.
5. Estimate the associated changes in the acceleration, time and power supply to actuate a MEMS component if its weight is reduced by a factor 20.
6. Estimate the variation of the total heat flow and the time required to transmit heat in a solid with a reduction of size by factor of 10. What will happen if the solid is of sub micro meter level.

Course Outcome 3 (CO3):

1. State the reason for which materials like silicon, Gallium Arsenide, germanium, quartz are preferred for sensors and actuators.
2. Draw the diagrams of three designated planes of silicon, showing number of atoms present.
3. Define smart materials.

4. With neat diagram explain the Czochralski method for growing single crystal silicon.
5. Explain in detail the role silicon and its compounds in MEMS.
6. Write detail notes on polymer materials used MEMS and microsystems.

Course Outcome 4 (CO4):

1. Distinguish between wet and dry etching.
2. Outline the general principle of diffusion process.
3. Name three mask materials used in etching.
4. Explain the general procedure of photolithography. Use neat diagrams.
5. Select and explain a process to deposit thin metallic films which result in a film with same chemical composition of the source material
6. Chose and explain a suitable micro fabrication process to fabricate

Course Outcome 5 (CO5):

1. State the purpose of packaging
2. Distinguish Microsystem from microelectronics packaging
3. Explain various levels of microsystem packaging
4. Explain various interfaces in microsystem packaging
5. Elaborate various packaging technologies

Concept Map

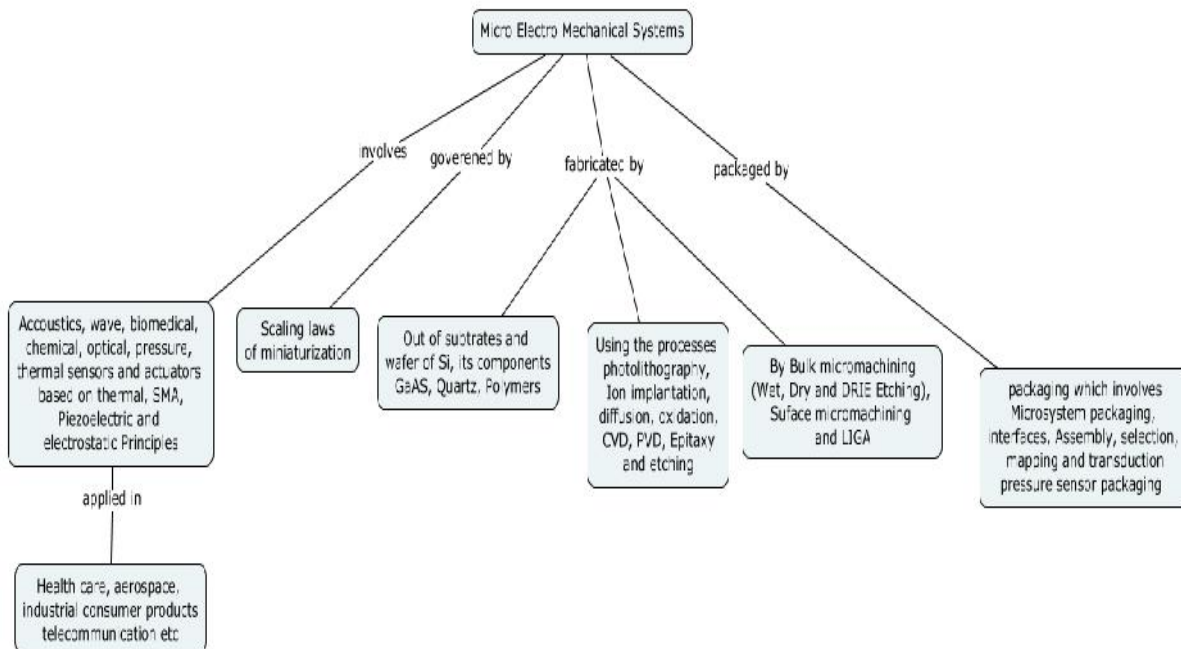

Syllabus

Overview of MEMS and Micro Systems: MEMS and Microsystems, products, Evolution of micro-fabrication, Micro system and Microelectronics, The multidisciplinary nature of MEMS, Miniaturization, applications of micro systems in automotive, health care, aerospace, and telecommunication fields.

Working Principles of Microsystems: Introduction, micro sensors: Acoustic waves, optical, chemical, pressure, thermal, biomedical and bio sensors. Microactuation: using thermal forces, shape memory alloys, piezoelectric crystals and electrostatics forces. MEMS with microactuators: microgrippers, micromotors, microvalves, micropumps, microaccelerometer,

Scaling law in miniaturization: Introduction to scaling, scaling in rigid body dynamics, electrostatic forces, electromagnetic forces, electricity, fluid mechanics and heat transfer.

Materials for MEMS and Microsystems: Introduction, substrate and wafers, active substrate materials, silicon, silicon compounds, silicon piezoresistors, polymers and packaging materials.

Microsystem fabrication process: Introduction, Photolithography, ion implantation, diffusion, oxidation, chemical vapour deposition, physical vapour deposition (sputtering), Deposition by epitaxy, wet and plasma etching.

Overview of Micromanufacturing: Introduction, bulk micromachining, surface micromachining, the LIGA process. Microsystem packaging: Introduction, Microelectronics packaging, Microsystem packaging, Interfaces in microsystem packaging, Essential packaging technologies, Pressure sensor packaging

Text Book

- 1.Tai –Ran Hsu, “**MEMS and Microsystem: Design and Manufacture**”, Tata McGraw Hill, First Edition, 2002.

Reference Books

- 1.G.K. Ananthasuresh, K. J. Vinoy, S. Gopalakrishnan, K.N. Bhat and V.K. Athrae “**Micro and Smart System**”, Wiley India Pvt Ltd, First edition, 2010
- 2.Chang Liu , “**Foundation of MEMS**”, 2nd Edition, Pearson education, 2012.
- 3.Marc J Madou: “**Fundamentals of microfabrication and nanotechnology**”, Three volume set 3rd revised Edition, Taylor and Francis, 2011
- 4.Gad El Hak (Editor), “**The MEMS Hand Book**”, Three volume set, 2nd revised Edition. CRC press, 2005.

Course Contents and Lecture Schedule

Module No.	Topic	No. of Lectures
1.	Overview of MEMS and Micro Systems:	
1.1	MEMS and Microsystems, products, Evolution of micro-fabrication, Micro system and Microelectronics	2
1.2	The multidisciplinary nature of MEMS, Miniaturization,	2
1.3	Applications of micro systems in automotive, health care, aerospace, and telecommunication fields	2

Module No.	Topic	No. of Lectures
	Working Principles of Microsystems:	
1.4	Introduction, microsensors: Acoustic waves, optical, chemical, pressure, thermal, biomedical and bio sensors.	2
1.5	Microactuation: using thermal forces, shape memory alloys, piezoelectric crystals and electrostatics forces.	2
1.6	MEMS with microactuators: microgrippers, micromotors, microvalves, micropumps, microaccelerometer, microfluidics	2
2	Scaling law in miniaturization:	
2.1	Introduction to scaling, scaling in rigid body dynamics, electrostatic forces,	2
2.2	Electromagnetic forces, electricity, fluid mechanics and heat transfer	2
3	Materials for MEMS and Microsystems:	
3.1	Introduction, substrate and wafers, active substrate materials	2
3.2	Silicon as substrate material, silicon compounds, silicon piezoresistors	2
3.3	Gallium Arsenide, Quartz, polymers and packaging materials.	1
4	Microsystem fabrication process:	
4.1	Introduction, Photolithography	1
4.2	Ion implantation, diffusion	1
4.3	Oxidation	1
4.4	Chemical vapour deposition	1
4.5	Physical vapour deposition(sputtering), Deposition by epitaxy,	1
4.6	Wet and plasma etching	1
	Overview of Micromanufacturing:	
4.7	Introduction, bulk micromachining,	1
4.8	Surface micromachining, The LIGA process	2
5	Microsystem packaging	
5.1	Introduction , Microelectronics packaging	2
5.2	Microsystem packaging	1
5.3	Interfaces in microsystem packaging	1
5.4	Essential packaging technologies	1

Module No.	Topic	No. of Lectures
5.5	Pressure sensor packaging	1
	Total	36

Course Designers:

1. Dr.G. Kumaraguruparan - gkgmech@tce.edu
2. Mr.T.Prakash - tpmech@tce.edu

Preamble

Additive Manufacturing is a group of techniques used to quickly fabricate a scale model of a physical part or assembly using three-dimensional computer aided design (CAD) data. Construction of the part or assembly is usually done using 3D printing or "additive layer manufacturing" technology. Additive manufacturing improves product development by enabling better communication in a concurrent engineering environment and also reduces product development cycle time. This course aims to provide knowledge on the additive manufacturing and its application, advantages, limitations.

Prerequisite

- Nil

Course Outcomes

On the successful completion of the course, students will be able to

CO1.	Explain the concepts of prototypes and AM process chain	Understand
CO2.	Select the suitable AM process for a given product/part drawing.	Apply
CO3.	Explain rapid tooling methods for Additive Manufacturing	Apply

Mapping with Programme Outcomes

Cos	PO1	PO2	PO3	PO4	PO5	PO6	PO7	PO8	PO9	PO10	PO11	PO12
CO1.	S	L	-	-	M	-	-	-	M	-	L	-
CO2.	S	M	-	-	M	-	-	-	S	-	S	-
CO3.	S	M	-	-	M	-	-	-	S	-	S	-

S- Strong; M-Medium; L-Low

Assessment Pattern

Bloom's Category	Continuous Assessment Tests			Terminal Examination
	1	2	3*#	
Remember	20	20	-	20
Understand	60	60	-	50
Apply	20	20	-	30
Analyse	-	-	-	-
Evaluate	-	-	-	-
Create	-	-	-	-

* - Fabrication of FDM product. Students are grouped as 3 or more per batch. Each batch will be given 90 minutes with 35cc material to fabricate the given component drawing.

- Evaluation pattern:

S. No	Description	Marks
1	CAD Model	45
2	Process chain	45
3	Finished Products	10
Total Marks		100

Course Level Assessment Questions

Course Outcome 1 (CO1):

1. Define Prototyping
2. Explain the process chain of additive manufacturing process
3. Explain the classification of additive manufacturing process

Course Outcome 2 (CO2):

1. Define polymerization Process
2. Explain the process parameters of Solid Ground Curing (SGC).
3. Explain the principle of Stereo lithography (SLA) processes.
4. Discuss the solid ground process steps in details with suitable diagrams.
5. Select the suitable AM process for the development of Pattern for jewellery application
6. Discuss the process parameters to be considered in selective laser sintering
7. Explain the process parameters considered for laminated object manufacturing.
8. Discuss the working principle of Fusion Deposition Modelling (FDM).
9. Select the suitable AM process for the development of Fixture for measurement purpose

Course Outcome 3 (CO3):

1. Differentiate direct and indirect tooling process.
2. Explain silicon rubber tooling processes in detail.
3. Differentiate soft tooling and hard tooling.
4. Select the suitable AM process for fabrication of injection moulding tool.

Concept Map

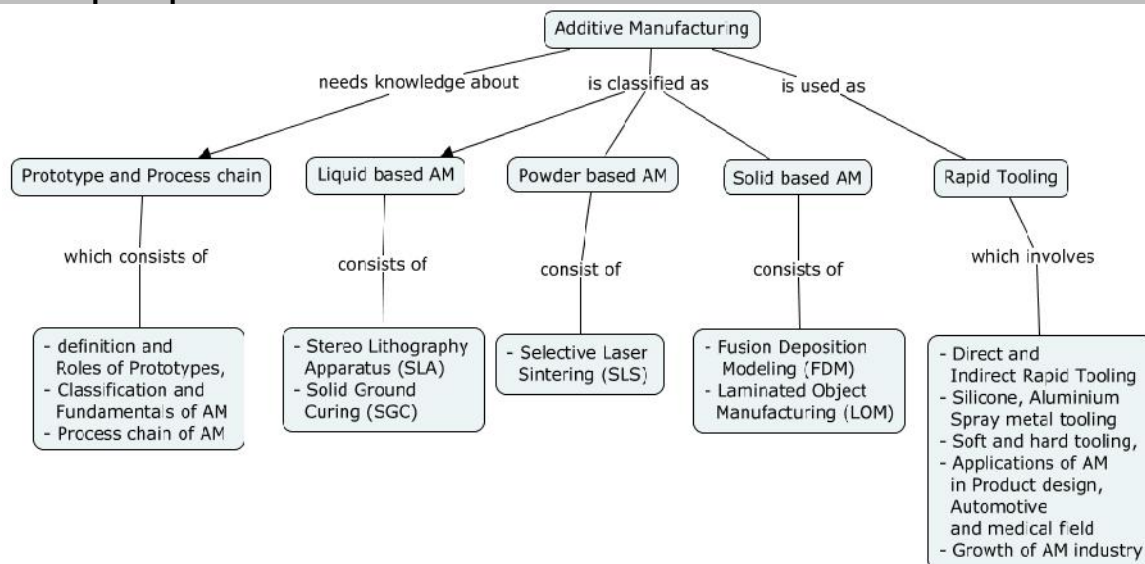

Syllabus

Introduction: Definition of Prototypes, Roles of Prototypes, Need for time compression in product development, History of AM Process, classification of AM Process - Fundamentals of AM Process – Process chain of AM Process – Data format – STL files. Benefits of AM.

Liquid Based AM: Stereo Lithography Apparatus (SLA) – Principle – Photo polymerization – Post processes – process parameters – Machine details – Advantages, Solid Ground Curing (SGC) – Principle – processes parameters – Process details - Machine details – Limitations.

Solid Based AM: Fusion Deposition Modeling (FDM) – Principle – Raw materials – BASS – Water soluble support system – Process parameters – Machine details – Advantages and limitations, Laminated Object Manufacturing – Principle – Processes parameters – Process details – Advantages and limitations.

Powder based AM: Selective Laser Sintering (SLS) – Principle – process parameters – Process details –Machine details.

Rapid Tooling and Applications of AM: Classification of Rapid Tooling - Indirect rapid tooling - Silicone rubber tooling, Aluminium filled epoxy tooling, Spray metal tooling, Direct rapid tooling - Direct ACES Injection Moulding. Soft tooling vs hard tooling, Applications of AM in product design, automotive industry, medical field – Case studies, Role of AM Process parameter on Part Quality, Growth of AM industry.

Text Books

1. Chua, C.K. Leong, K.F. and Lim, C.S. “**Rapid Prototyping: Principles and Applications**”, World Scientific, New Jersey, 2010
2. Pham, D.T. and Dimov, S.S., “**Rapid manufacturing**”, Springer-Verlag, Londo, 2011

Reference Books

1. Jacobs, P.F., “**Rapid Prototyping and Manufacturing: Fundamentals of Stereolithography**”, McGraw-Hill, New York, 2011
2. Hilton. P.D., “**Rapid Tooling**”, Marcel Dekker, New York, 2000.
3. **Rapid Prototyping Journal**, Emerald Group Publishing Limited
4. www.utah.edu/~asn8200/rapid.html
5. <http://www.cheshirehenbury.com/rapid/index.html>

Course Contents and Lecture Schedule

Module Number	Topic	No. of Lectures
1	Introduction:	
1.1	Definition of Prototypes, Roles of Prototypes	1
1.2	History of AM Process, classification of AM Process, benefits of AM.	1
1.3	Need for time compression in product development	1
1.4	Fundamentals of AM Process – Process chain of AM Process – Data format – STL files	2
2	Liquid Based AM:	
2.1	Stereo Lithography Apparatus(SLA) – Principle	1

2.2	Photo polymerization – Post processes - process parameters	2
2.3	Machine details – Advantages,	2
2.4	Solid Ground Curing (SGC) – Principle	2
2.5	Processes parameters	1
2.6	Process details - Machine details – Limitations	2
3	Solid Based AM:	
3.1	Fusion Deposition Modeling (FDM) – Principle – Raw materials – BASS	2
3.2	Water soluble support system – Process parameters	2
3.3	Machine details – Advantages and limitations	1
3.4	Laminated Object Manufacturing – Principle – Processes parameters - Process details – Advantages and limitations	2
4	Powder based AM:	
4.1	Selective Laser Sintering (SLS) – Principle – process parameters	2
4.2	Process details –Machine details	1
5	Rapid Tooling and Applications of AM:	
5.1	Classification of Rapid Tooling - Indirect Rapid Tooling – Silicone rubber tooling, Aluminium filled epoxy tooling, Spray metal tooling	2
5.2	Direct Rapid Tooling – Direct ACES Injection Moulding - soft tooling Vs hard tooling	2
5.3	Applications of AM in product design, automotive industry, medical field	2
5.4	Case studies	2
5.5	Role of AM Process parameter on Part Quality	2
5.6	Growth of AM industry	2
	Total	36

Course Designers:

1. Dr.K. Chockalingam kcmech@tce.edu
2. Mr.T. Prakash tpmech@tce.edu

Preamble

A dynamic and highly competitive business environment requires an increasingly efficient and controllable product development process. This dynamic process demand more creative and innovative solutions that provide the challenging and diverse requirements of the customer. This course aims to prepare the students to move forward in innovative settings.

Prerequisite

- 14MT420-Engineering Design

Course Outcomes

On the successful completion of the course, students will be able to

CO1.	Explain Concept of product development , Sustenance Engineering and End of life ,Product development in Industry versus Academia, Trade-offs, Intellectual Property Rights and Confidentiality	Understand
CO2.	Classify the Product Development methodologies.	Understand
CO3.	Perform the PESTLE Analysis and Requirement Engineering Analysis.	Apply
CO4.	Develop System Integration, Testing, Certification and Documentation.	Apply
CO5.	Identify the specific product development process for a given industry.	Apply
CO6.	Transform customer needs into technical specification of a product.	Apply

Mapping with Programme Outcomes

COs	PO1	PO2	PO3	PO4	PO5	PO6	PO7	PO8	PO9	PO10	PO11	PO12
CO1.	S	S	S	M	L	S	S	L	S	M	S	M
CO2.	S	S	S	M	L	S	S	L	S	S	S	M
CO3.	S	S	S	S	L	S	M	M	S	S	M	M
CO4.	S	S	S	M	L	S	M	S	S	S	S	S
CO5.	S	S	S	S	L	S	M	L	S	M	M	M
CO6.	S	S	S	S	L	S	S	L	S	S	S	M

S- Strong; M-Medium; L-Low

Assessment Pattern

Bloom's Category	Continuous Assessment Tests			Terminal Examination
	1	2	3	
Remember	20	20	20	20
Understand	30	30	30	30
Apply	50	50	50	50
Analyse	—	—	—	—
Evaluate	—	—	—	—
Create	—	—	—	—

Course Level Assessment Questions

Course Outcome 1 (CO1):

1. Define product design.
2. Define Intellectual Property.
3. Define proto typing.

Course Outcome 2 (CO2):

1. Distinguish between functional design and production design, with suitable examples.
2. Discuss the different types of product validation techniques.
3. Explain the concept selection process with example.

Course Outcome 3 (CO3):

1. As a customer identify the basic needs in the selection of a new car.
2. Select the suitable product development methodology for software companies and criticize your selection.
3. Construct the house of quality for a basic mobile phone.

Course Outcome 4 (CO4):

1. Select the innovation criteria for product success in the life cycle of a product.
2. How concept selection methods can is used to benchmark or evaluate the existing product?
3. Evaluate concept selection methods for five automobiles you might consider for purchasing.

Course Outcome 5 (CO5):

1. As a customer Identify the basic needs while selection a new car
2. Decompose a micro oven into its assemblies, components, electrical circuits.
3. Draw the product architecture for a ink jet printer

Course Outcome 6 (CO6):

1. Develop different concepts to design an orange ripeness tester and evaluate
2. List your needs with respect to two wheeler motorcycle suspension and convert to a product specification.
3. Determine and evaluate the force flow in a car door being opened

Concept Map

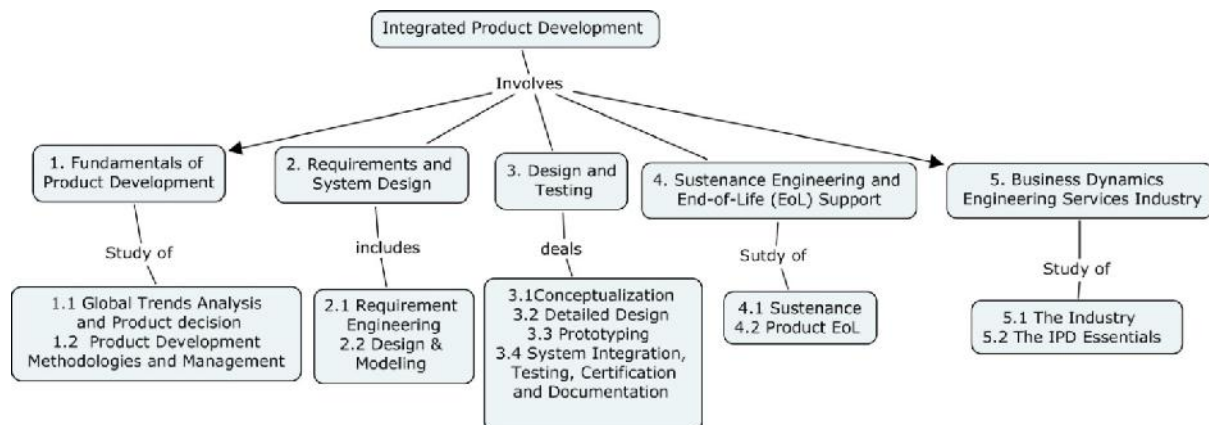

Syllabus

Product Development -Global Trends Analysis and Product decision- Types of various trends affecting product decision - Social Trends (Demographic, Behavioral, Psychographic), Technical Trends(Technology, Applications, Tools, Methods), Economical Trends(Market, Economy, GDP, Income Levels, Spending Pattern, target cost, Total Cost of Ownership), Environmental Trends (Environmental Regulations and Compliance), Political/Policy Trends(Regulations, Political Scenario, IP Trends and Company Policies).

PESTLE Analysis-Introduction to Product Development Methodologies and Management Overview of Products and Services (Consumer product, Industrial product, Specialty products etc.)- Types of Product Development (NPD/ Re-Engineering (Enhancements, Cost Improvements)/ Reverse Engineering/ Design Porting & Homologation)- Overview of Product Development methodologies (Over the Wall/ Waterfall/ V-Model/ Stage-Gate Process/ Spiral/Systems Engineering/ Agile)- Product Life Cycle (S-Curve, Reverse Bathtub Curve)- Product Development Planning and Management (Budgeting, Risk, Resources and Design Collaboration, Scheduling, Change Management, Product Cost Management) Requirements and System Design- Requirement Engineering-Types of Requirements (Functional, Performance, Physical, Regulatory, Economical, Behavioral, Technical, Stakeholder, Environmental, Industry specific, Internal-Company Specific)- Requirement Engineering (Gathering (VOC), Analysis (QFD), Design Specification)- Traceability Matrix and Analysis-Requirement Management- Design and Testing-Conceptualization Industrial Design and User Interface Design-Introduction to Concept generation Techniques- Concept Screening & Evaluation -Concept Design -S/W Architecture -Hardware Schematics and simulation - Detailed Design -component Design and Verification-High Level Design/Low Level Design of S/W Programs, S/W Testing Hardware Schematic, Component design, Layout and Hardware Testing Prototyping -Types of Prototypes (Mockups, Engineering Assessment Prototype, Alpha, Beta, Gama)- System Integration, Testing, Certification and Documentation.

Manufacturing/Purchase and Assembly of Systems-: Integration of Mechanical, Embedded and S/W systems-: Introduction to Product verification processes and stages – Industry specific (DFMEA, FEA)- Introduction to Product validation processes and stages - Industry specific (Sub-system Testing/ Integration Testing/ Functional Testing/ Performance Testing / Compliance Testing)- Product Testing standards and Certification – Industry specific- Product Documentation overview only (Compliance Documentation, Catalogue, Brochures, user manual, maintenance Manual, Spares Parts List, Warranty, Disposal Guide, Interactive Electronic Technical Manual, Web Tools)-Sustenance Engineering and End-of-Life (EoL) Support-Sustenance-Maintenance and Repair-Enhancements, Obsolesce - Obsolescence Management- Configuration Management- EoL Disposal- Business Dynamics – Engineering Services Industry-The Industry- Engineering Services Industry – overview- Product development in Industry versus Academia The IPD Essentials -Introduction to vertical specific product development processes- Product development Trade-offs-: Intellectual Property Rights and Confidentiality- Security and configuration management

Text Book

1. **Foundation skills in Integrated product development (FSIPD)** , NASSCOM, Edition 2015

Reference Books

1. Karl T.Ulrich and Steven D.Eppinger , **“Product Design and Development”**, McGraw –Hill International Edns.2007.
2. David G.Ullman, **“The Mechanical Design Process”**, Tata McGraw Hill, 2011.
3. Stephen Rosenthal, **“Effective Product Design and Development”**, Business One Irwin, Homewood, 1992.

4. Stuart Pugh, “**Tool Design – Integrated Methods for Successful Product Engineering**”, Addison Wesley Publishing, Newyork, NY, 1991.
5. Kevin Otto, and Kristin Wood, “**Product Design – Techniques in Reverse Engineering and New Product Development**”, Pearson Education, 2003.
6. **Product Design – Techniques in Reverse Engineering and New Product Development**, Kevin Otto, and Kristin Wood, Pearson Education, ISBN 81-7758-821-4

Course Contents and Lecture Schedule

S.No.	Topic	No. of Lectures
1.1	Global Trends Analysis and Product decision	
1.1.1	Types of various trends affecting product decision - Social Trends (Demographic, Behavioral, Psychographic), Technical Trends(Technology, Applications, Tools, Methods),	1
1.1.2	Economical Trends(Market, Economy, Gross Domestic Product, Income Levels, Spending Pattern, target cost, Total Cost of Ownership)	1
1.1.3	Environmental Trends(Environmental Regulations and Compliance), Political/Policy Trends(Regulations, Political Scenario, IP Trends and Company Policies.	1
1.1.4	PESTLE Analysis	1
1.2	Introduction to Product Development Methodologies and Management	
1.2.1	Overview of Products and Services (Consumer product, Industrial product, Specialty products etc.,)	1
1.2.2	Types of Product Development (NPD/ Re-Engineering (Enhancements, Cost Improvements)/ Reverse Engineering/ Design Porting & Homologation)	1
1.2.3	Overview of Product Development methodologies (Over the Wall/ Waterfall/ V-Model/ Stage-Gate Process/ Spiral/Systems Engineering/ Agile)	1
1.2.4	Product Life Cycle (S-Curve, Reverse Bathtub Curve)	1
1.2.5	Product Development Planning and Management (Budgeting, Risk, Resources and Design Collaboration, Scheduling, Change Management, Product Cost Management)	1
2.1	Requirement Engineering	
2.1.1	Types of Requirements (Functional, Performance, Physical, Regulatory, Economical, Behavioral, Technical, Stakeholder, Environmental, Industry specific, Internal-Company Specific)	1
2.1.2	Requirement Engineering (Gathering (VOC), Analysis (QFD), Design Specification)	1
2.1.3	Traceability Matrix and Analysis	1
2.1.4	Requirement Management	1
3.1	Conceptualization	
3.1.1	Industrial Design and User Interface Design	1
3.1.2	Introduction to Concept generation Techniques	
3.1.3	Concept Screening & Evaluation -Concept Design – Software Architecture- Hardware Schematics and simulation	1
3.2	Detailed Design	
3.2.1	Component Design and Verification	1

S.No.	Topic	No. of Lectures
3.2.2	High Level Design/Low Level Design of Software Programs, Software Testing	1
3.2.3	Hardware Schematic, Component design, Layout and Hardware Testing	1
3.3	Prototyping	
3.3.1	Types of Prototypes (Mockups, Engineering Assessment Prototype, Alpha, Beta, Gama)	2
3.4	System Integration, Testing, Certification and Documentation	
3.4.1	Manufacturing/Purchase and Assembly of Systems - Integration of Mechanical, Embedded and S/W systems	1
3.4.2	Introduction to Product verification processes and stages – Industry specific (DFMEA, FEA)	1
3.4.3	Introduction to Product validation processes and stages - Industry specific (Sub-system Testing/ Integration Testing/ Functional Testing/ Performance Testing / Compliance Testing)	1
3.4.4	Product Testing standards and Certification – Industry specific	1
3.4.5	Product Documentation – overview only (Compliance Documentation, Catalogue, Brochures, user manual, maintenance Manual, Spares Parts List, Warranty, Disposal Guide, Interactive Electronic Technical Manual, Web Tools)	1
4.1	Sustenance	
4.1.1	Maintenance and Repair, Enhancements.	2
4.2	Obsolesce	
4.2.1	Obsolescence Management - Configuration Management- EoL Disposal	2
5.1	Business Dynamics – Engineering Services Industry	
5.1.1	Engineering Services Industry – overview-	1
5.1.2	Product development in Industry versus Academia	2
5.2	The IPD Essentials	
5.2.1	Introduction to vertical specific product development processes	1
5.2.2	Product development Trade-offs	1
5.2.3	Intellectual Property Rights and Confidentiality Security and configuration management	2
Total		36

Course Designers:

1. Mr.M.Elango - memech@tce.edu
2. Mr.J. Umar Mohamed - umar_tce_mech@tce.edu

Preamble

This course instructs the students in the use of VERILOG (VERILOG Hardware Description Language) for describing the behavior of digital systems. VERILOG is a standardized design language used in computer/ semiconductor industry. This course will teach students the use of the VERILOG language for representation of digital signals, use of IEEE standard logic package/library, design description, design of arithmetic, combinational, and synchronous sequential circuits.

Prerequisite

- 14MT270-Analog and Digital Devices.
- 14MT430-Analog and Digital Circuits Design.

Course Outcomes

On the successful completion of the course, students will be able to

CO1.	Introduce VERILOG programming and design concepts for combinational and sequential circuits	Remember
CO2.	list and describe various programmable logical devices	Understand
CO3.	design and demonstrate the working of various arithmetic operations using VERILOG	Apply
CO4.	illustrate the state machine design concepts used in digital design of various circuits	Apply

Mapping with Programme Outcomes

COs	PO1	PO2	PO3	PO4	PO5	PO6	PO7	PO8	PO9	PO10	PO11	PO12
CO1.	S	S	M	-	-	-	-	-	-	-	L	-
CO2.	S	S	M	-	-	M	-	L	-	-	-	-
CO3.	S	S	M	-	-	M	-	L	-	-	-	-
CO4.	S	S	M	-	-	-	-	-	L	-	L	-

S- Strong; M-Medium; L-Low

Assessment Pattern

Bloom's Category	Continuous Assessment Tests			Terminal Examination
	1	2	3	
Remember	20	20	20	10
Understand	40	40	40	40
Apply	40	40	40	50
Analyse	0	0	0	0
Evaluate	0	0	0	0
Create	0	0	0	0

Course Level Assessment Questions

Course Outcome 1 (CO1):

1. Describe Moore's Law for VHDL?
2. Write an VHDL code for Binary to Gray code Converter
3. Define the some VHDL operators with an example
4. Distinguish between Combinational and sequential circuits

Course Outcome 2 (CO2):

1. Define the functionality PLA and PAL
2. List the different types of Read only memories.
3. Define the functionality of
4. Show that how do you access the peripherals in 8051

Course Outcome 3(CO3):

1. Demonstrate the working of serial adder with VHDL code
2. Give an example for 3 bit multiplier
3. Describe the differences in signed and unsigned multiplication
4. Develop a VHDL code for 4 bit BINARY divider,

Course Outcome 4 (CO4):

1. Demonstrate the modelling of state machine charts.
2. Give an example for digital design circuit using SM chart.
3. Describe the Derivation of SM chart.
4. Distinguish between state machine and linked state machine.

Concept Map

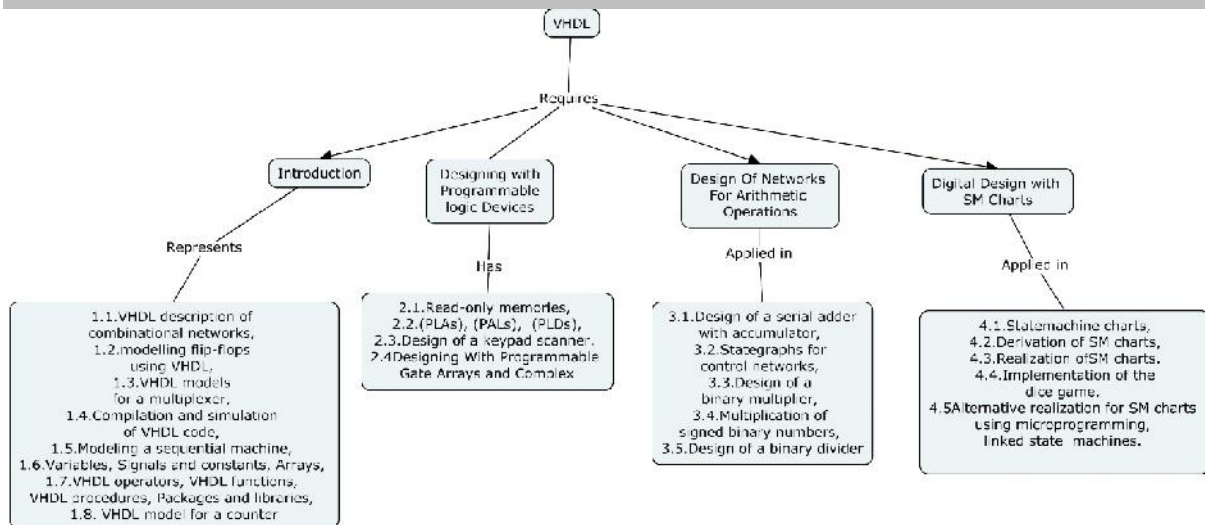

Syllabus

Introduction: VERILOG description of combinational networks, modelling flipflops using Verilog, VERILOG models for a multiplexer, Compilation and simulation of VERILOG code, Modeling a sequential machine, Variables, Signals and constants, Arrays, VERILOG operators, VERILOG functions, VERILOG procedures, Packages and libraries, VERILOG model for a counter.

Designing With Programmable Logic Devices:

Read-only memories, Programmable logic Arrays (PLAs), Programmable array logic (PALs)

other sequential programmable logic devices (PLDs), FPGA – Spartan architecture, interconnects, FPGA programming using Verilog.Design of a keypad scanner.

Designing With Programmable Gate Arrays and Complex.

Design Of Networks For Arithmetic Operations: Design of a serial adder with accumulator, State graphs for control networks, Design of a binary multiplier, Multiplication of signed binary numbers, Design of a binary divider. **Digital Design with SM Charts:** State machine charts, Derivation of SM charts, Realization of SM charts. Implementation of the dice game, Alternative realization for SM charts using microprogramming, linked state machines.

Text books:

1. Charles H. Roth. Jr, **Digital Systems Design using VHDL**, Thomson Learning, Inc, 9th reprint, 2006.
2. Stephen Brown & Zvonko Vranesic, **Fundamentals of Digital Logic Design with VHDL**, Tata McGraw-Hill, New Delhi, 2nd Ed., 2007.

Reference books:

1. Mark Zwolinski, **Digital System Design with VHDL**, 2 Ed, Pearson Education., 2004
2. Volnei A Pedroni . **Circuit Design with VHDL**. MIT Press, 2004 First Correction

Lecture Schedule

Module no.	Topic	No. Of lectures
1.	INTRODUCTION	
1.1	VERILOG description of combinational networks	2
1.2	modelling of flip-flops using Verilog	1
1.3	VERILOG models for a multiplexer	1
1.4	compilation and simulation of Verilog code	1
1.5	modelling a sequential machine	2
1.6	variables, signals and constants, arrays	1
1.7	VERILOG operators, VERILOG functions , VERILOG procedures, packages and libraries	1
1.8	VERILOG model for a counter	2
2	DESIGNING WITH PROGRAMMABLE LOGIC DEVICES	
2.1	read-only memories	2
2.2	programmable logic arrays (PLA), programmable array logic (PAL), other sequential programmable logic devices (PLD)	2

2.3	FPGA – Spartan architecture, interconnects, FPGA programming using VERILOG	2
2.4	design of a keypad scanner	2
2.5	designing with programmable gate arrays and complex	2
3	DESIGN OF NETWORKS FOR ARITHMETIC OPERATIONS	
3.1	design of a serial adder with accumulator	2
3.2	state graphs for control networks	2
3.3	design of a binary multiplier	2
3.4	multiplication of signed binary numbers	1
3.5	design of a binary divider	2
4	DIGITAL DESIGN WITH SM CHARTS	
4.1	state machine charts, derivation of sm charts	2
4.2	realization of sm charts	2
4.3	implementation of the dice game	1
4.4	Alternative realization for SM charts using micro programming, linked state machines	1
Total		36

Course Designers:

- | | | |
|-----------------------|---|-------------------------|
| 1. Dr. L.R.Karlmarx | - | lrkarlmarx@tce.edu |
| 2. Mr.S.Parthasarathi | - | parthasarathi_s@tce.edu |

14MTPF0 TOTAL QUALITY MANAGEMENT

Category	L	T	P	Credit
PC	3	0	0	3

Preamble

Quality is the mantra for success or even for the survival of any organization to have continuous Quality Improvement, customer focus and teamwork. Total Quality Management (TQM) is an enhancement to the traditional way of doing business. It is a proven technique to guarantee survival in world-class competition. It integrates fundamental management techniques, existing improvement efforts, and technical tools under a disciplined approach. At the end of the course the students are expected to recognize the quality issues in an organization and analyze the ways to solve those using TQM techniques, and demonstrate skills in using modern TQM tools and software to analyze problems.

Prerequisite

- NIL

Course Outcomes

On the successful completion of the course, students will be able to,

CO 1.	Evaluate the principles of quality management and to explain how these principles can be applied within quality management systems.	Understand
CO 2.	Identify the aspects of the quality improvement cycle by applying QC, 5S and KAIZEN	Apply
CO 3.	Select and use seven quality tools and explain the sampling plans	Apply
CO 4.	Apply techniques like QFD, FMEA, Benchmarking process for controlling, improving and measuring quality.	Apply
CO 5.	Illustrate various ISO standards and quality systems in an organization.	Understand

Mapping with Programme Outcomes

COs	PO1	PO2	PO3	PO4	PO5	PO6	PO7	PO8	PO9	PO10	PO11	PO12
CO 1.	-	-	-	-	-	M	-	M	-	-	-	M
CO 2.	-	M	-	-	M	M	-	M	S	M	-	-
CO 3.	-	S	-	-	M	M	-	-	-	M	-	-
CO 4.	-	M	-	-	-	-	-	-	S	M	-	-
CO 5.	-	-	-	-	-	-	-	M	-	M	-	M

S- Strong; M-Medium; L-Low

Assessment Pattern

Assignment: One Mini Project for 10Marks

Bloom's Category	Continuous Assessment Tests			Terminal Examination
	1	2	3	
Remember	20	20	20	20
Understand	60	30	30	30
Apply	20	50	50	50
Analyse	-	-	-	-
Evaluate	-	-	-	-
Create	-	-	-	-

Course Level Assessment Questions

Course Outcome 1 (CO1):

1. List out the various dimensions of product and service quality.
2. Describe about various Quality Statements.
3. Explain the basic steps in bench marking process.
4. Explain about implementation stages of Quality circles.

Course Outcome 2 (CO2):

1. What are the important factors that a customer will think about while purchasing a product.
2. Explain how would you make the employees in an organization to work together to achieve the common goal.
3. Mention about work place management in terms of 5S.
4. Explain Kaizen.

Course Outcome 3 (CO3):

1. A machine is working to a specification of 12.58 ± 0.05 mm. A study of 50 consecutive pieces shows the following measurements put into 10 groups of 3 each:

1	2	3	4	5	6	7	8	9	10
12.62	12.63	12.62	12.61	12.59	12.57	12.57	12.58	12.61	12.56
12.60	12.56	12.56	12.66	12.58	12.63	12.56	12.57	12.60	12.59
12.62	12.60	12.57	12.62	12.57	12.60	12.61	12.60	12.62	12.62
12.61	12.59	12.58	12.61	12.59	12.60	12.59	12.60	12.60	12.58
12.65	12.60	12.63	12.60	12.56	12.59	12.59	12.61	12.65	12.54

- a) Determine Control Limits and draw \bar{X} and R chart.
 - b) Determine Process capability.
 - c) Does it appear that the machine is capable of meeting the specification requirements.
 - d) Calculate % defective if any.
 - e) Suggest possible way to reduce the percent defectives.
2. Following are the inspection results of magnets for 16 hours.

Hour	1	2	3	4	5	6	7	8	9
No. of magnets inspected	48	36	50	47	48	54	50	42	32
No. of defective units	5	5	0	5	0	3	0	1	5

- a) Construct appropriate control charts.
 - b) State whether the process is in statistical control.
 - c) Indicate the values that are out of control.
3. Suppose that a product is shipped in lots of size $N=5000$. The receiving inspection procedure used is single sampling with $n=50$ and $c=1$.
- a) Draw the type-A OC curve for the plan.
 - b) Draw the type-B OC curve for this plan and compare it to the type-A OC curve found in part (a).
 - c) Which curve is appropriate for the situation?

Course Outcome 4 (CO4):

1. Explain about new seven management tools.
2. Design a FMEA document by identifying the failure modes in Hole drilling process. In the process, Consider $S=5$, $O=9$, $D=4$, Find RPN. After action plan $S=5$, $O=1$, $D=1$. Recalculate RPN After Completion of Action Plans and Validate Improvements.
3. Build the house of quality matrix to show the inter relationship between the customer requirements and technical descriptors for a manufacturing system.

Course Outcome 5 (CO5):

1. Explain what is the need of ISO 9001: 2015 and how will you implement it in your organisation.
2. Explain about the environmental implications on the society. Discuss the mandatory items of ISO 14000.
3. Discuss about the requirements and the benefits of implementing OSHAS 18000.

Concept map

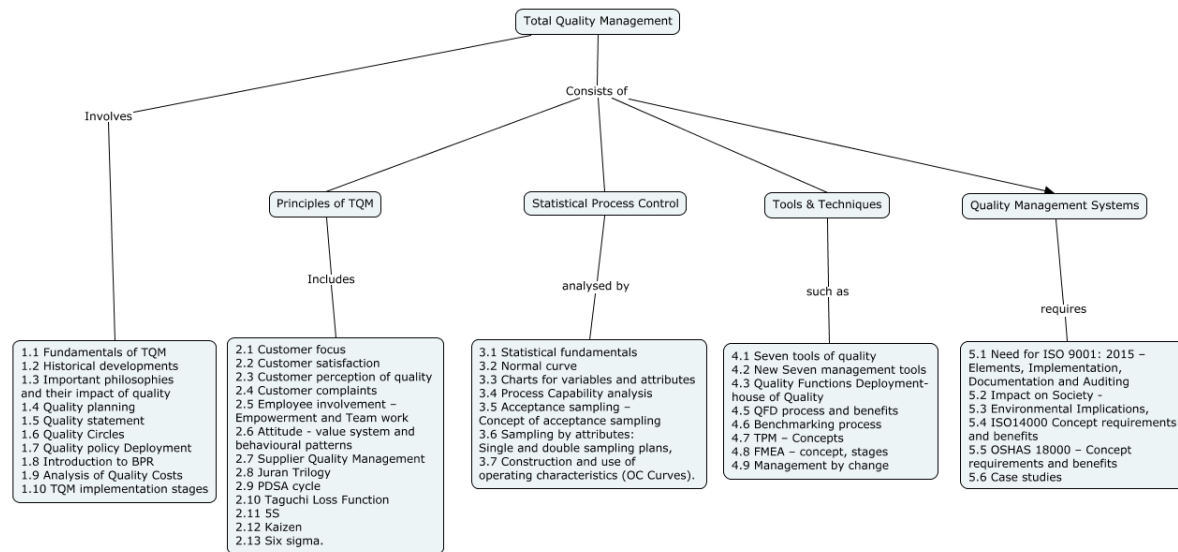

Syllabus

Introduction: Fundamentals of TQM – Historical developments – important philosophies- (Deming, Juran, Crosby, Ishikawa) and their impact of quality – Quality planning, Quality statement, Quality Circles, Quality policy Deployment, introduction to BPR and analysis of Quality Costs- TQM implementation stages

Principles of TQM: Customer focus - Customer satisfaction – customer perception of quality, customer complaints, Employee involvement – Empowerment and Team work, Attitude - value system and behavioural patterns, Supplier Quality Management, Juran Trilogy, PDCA cycle, Taguchi Loss Function, 5S, Kaizen, Six sigma.

Statistical Quality Control (SQC): Statistical fundamentals – Normal curve, charts for variables and attributes, Process Capability analysis, Acceptance sampling – Concept of acceptance sampling, Sampling by attributes: Single and double sampling plans, Construction and use of operating characteristics (OC Curves).

TQM Tools and Techniques: Seven tools of quality, New Seven management tools, Quality Functions Deployment (QFD) – house of Quality, QFD process and benefits, Benchmarking process, TPM – Concepts, FMEA – concept, stages, Management by change.

Quality Management Systems: Need for ISO 9001: 2015 – Elements, Implementation, Documentation and Auditing, Impact on Society - Environmental Implications, ISO14000 and OSHAS 18000 – Concept requirements and benefits – Case studies.

Text Books

1. Dale H. Besterfield, Carol Besterfield-Michna, Glen H. Besterfield and Mary Besterfield-Sacre., "Total Quality Management", Pearson Education Asia, 3rd edition, 2011.

2. D.C.Montgomery, "**Introduction to Statistical Quality Control**", John-Wiley & Sons Inc.New York,6th edition, 2009

Reference Books

1. Amitava Mitra, "**Fundamentals of Quality control and Improvement**", John Wiley and Sons,Inc, NewJersey, 2016
1. Shridhara Bhat, "**TQM – Text and Cases**", Himalaya publishing House, 2002.
2. Janakiraman.B and Gopal .R.K, "**Total Quality Management – Text and Cases**", Prentice Hall(India) Pvt. Ltd., 2006.
3. James R.Evans and William M.Lindsay, "**The management and control of Quality**", 8th edition, 2012
4. Sharma, D.D, "**Total Quality Management**", Sultan Chand & Sons, 2005.

Course contents and Lecture schedule

No	Topic	No. of Lectures
1.0	Introduction	
1.1	Fundamentals of TQM – Historical developments	1
1.2	Important philosophies- (Deming, Juran, Crosby, Ishikawa) and their impact of quality –	2
1.3	Quality planning, Quality statement	1
1.4	Quality Circles	1
1.5	Quality policy Deployment	1
1.6	Introduction to BPR	1
1.7	Analysis of Quality Costs	1
1.8	TQM implementation stages	1
2.0	Principles of TQM	
2.1	Customer focus - Customer satisfaction, Customer perception of quality, customer complaints	1
2.2	Employee involvement – Empowerment and Team work	1
2.3	Attitude - value system and behavioural patterns	1
2.4	Supplier Quality Management	1
2.5	Juran Trilogy, PDSA cycle, Taguchi Loss Function	1
2.6	5S	1
2.7	Kaizen	1
2.8	Six sigma.	1

No	Topic	No. of Lectures
3.0	Statistical Quality Control (SQC)	
3.1	Statistical fundamentals- Normal curve	2
3.2	Charts for variables	1
3.3	Charts for attributes	1
3.4	Process Capability analysis,	1
3.5	Acceptance sampling – Concept of acceptance sampling, Sampling by attributes: Single and double sampling plans	2
3.6	Construction and use of operating characteristics (OC Curves).	1
4.0	TQM Tools and Techniques	
4.1	Seven tools of quality, New Seven management tools	1
4.2	Quality Functions Deployment (QFD) – house of Quality, QFD process and benefits	1
4.3	Benchmarking process	1
4.4	TPM – Concepts	1
4.5	FMEA – concept, stages	1
4.6	Management by change.	1
5.0	Quality Management Systems:	
5.1	Need for ISO 9001: 2015 – Elements, Implementation, Documentation and Auditing	1
5.2	Impact on Society - Environmental Implications	1
5.3	ISO14000 - Concept requirements and benefits	1
5.4	OSHAS 18000 – Concept requirements and benefits	1
5.5	Case studies.	1
	TOTAL	36

Course Designers:

1.Dr.M.Palaninatharaja
2.Mr.B.Praveen Kumar

pnatharaja@tce.edu
bpkmech@tce.edu

14MTPG0**SMART MATERIALS FOR
MECHATRONICS**

Category	L	T	P	Credit
PE	3	0	0	3

Preamble

Smart Materials have properties that can be altered by temperature, moisture, electric or magnetic fields, pH, stress. They can change shape and color, become stronger, or produce voltage as a result of external stimuli. Smart materials which find widespread applications today should be recognized along with familiar metals, plastics, ceramics, composites, powder metals, and specialty-type and multifunctional materials, functionally graded materials. Smart materials have emerged as the novel materials for engineering applications. By using smart materials, one can endow structures with built-in responses to innumerable contingencies. In their various forms, these materials can perform as actuators, which can adapt to their environments by changing characteristics such as shape and stiffness, or as sensors, which provide the actuators with information about structural and environmental changes. This course introduces the different types of smart materials to students and some applications of smart materials as actuators, sensors, vibration dampers etc.,

Prerequisite

- 14PH120- Physics
- 14MT240-Materials for Mechanical and Electronic Systems

Course Outcomes

On the successful completion of the course, students will be able to

CO 1.	Understand the basic mechanisms of Smart Materials	Remember
CO 2.	Select the Smart Materials for Magneto-Thermo-Mechanical Applications	Understand
CO3.	Investigate the parameters used in strain measurements	Apply
CO 4.	Analyse the Smart Materials based micro sensors and micro actuators	Apply
CO 5.	Review the newly discovered smart materials	Understand

Mapping with Programme Outcomes

COs	PO1	PO2	PO3	PO4	PO5	PO6	PO7	PO8	PO9	P10	P11	P12
CO1	S	L	-	-	-	-	-	-	-	-	-	-
CO2	S	S	S	-	-	-	-	-	-	-	-	-
CO3	S	S	S	S	-	-	-	-	-	-	-	-
CO4	S	S	S	S	-	-	-	-	-	-	-	S
CO5	S	L	L	L	-	-	-	-	-	-	-	S

S- Strong; M-Medium; L-Low

Assessment Pattern

Bloom's Category	Continuous Assessment Tests			Terminal Examination
	1	2	3	
Remember	20	20	20	20
Understand	30	40	30	50
Apply	50	40	50	30
Analyse	-	-	-	-
Evaluate	-	-	-	-
Create	-	-	-	-

Course Level Assessment Questions

Course Outcome 1 (CO1):

1. What are Smart Materials?
2. Distinguish between the conventional shape memory alloys and the magnetic shape memory alloys.
3. Outline the importance of Villari effect and Joule effect.
4. Write constitutive equations used in piezoelectric and magnetostrictive materials.
5. Group the emerging smart materials.

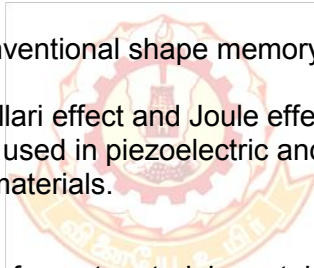

Course Outcome 2 (CO2):

1. Identify the various classes of smart materials pertaining to Mechatronics Applications.
2. Illustrate the macroscopic and microscopic mechanisms of shape memory alloys.
3. Interpret the piezoelectric coefficients used for making micro actuator.
4. Summarize the similarities and dissimilarities of Ferromagnetic shape memory alloys and magnetostrictive materials
5. Research the latest developments in energy harvesting materials.

Course Outcome 3 (CO3):

1. Manipulate the differences between the one-way shape memory alloys and two-way shape memory alloys.
2. Compute the amount of strain (in %) required for the construction of the piezoelectric actuators.
3. Exhibit the large magnetic field induced strain in ferromagnetic shape memory alloys and saturation magnetization in magnetostrictive materials.
4. Apply the 'longitudinal loading' in smart polymer composites.

Course Outcome 4 (CO4):

1. Compute the maximum temperature required for a Shape Memory Alloy (SMA) rod. A SMA rod is to be used in an application requiring its ends to be held rigid. If the SMA rod is stress free at room temperature, what is the maximum temperature to which the SMA rod may be heated without exceeding a compressive stress of 185 MPa. Assume the modulus of elasticity of 125 GPa.
2. Construct a cubic austenitic ferromagnetic shape memory alloy hat has a saturation magnetization od $5.25 \times 10^5 \text{ Am}^{-1}$ for micro actuator applications. Assume that the phase transformations between the cubic austenite and the tetragonal martensite is occurred at room temperature.

- Demonstrate the force generation of a piezo actuator with nominal displacement of $30 \mu\text{m}$ and stiffness of $200 \text{ N}/\mu\text{m}$? The piezo actuator can produce a maximum force of $30 \mu\text{m} \times 200 \text{ N}/\mu\text{m} = 6000 \text{ N}$. When force generation is maximum, displacement is zero and vice versa.

Course Outcome 5 (CO5):

- Comprehend the fabrication of three dimensional nanostructures.
- Describe the size dependent macroscopic properties of intelligent materials, with examples.
- Discuss the role of smart materials in 'structural health monitoring'.
- Consider the following actuation principles and corresponding smart materials and match them.

Actuation Principle

- Martensite transformation
- Twin boundary motion
- Piezoelectric effect
- Magnetostriction

Smart Material

- Lead Zirconate Titanate
- Terfenol-D
- Ni_2MnGa
- Nitinol

- Consider the following statements

- Ferromagnetic shape memory effect is due to twin boundary motion
- Shape memory effect in Nitinol is due to martensite transformation
 - A only true
 - B only true
 - Both A and B are true
 - Both A and B are false

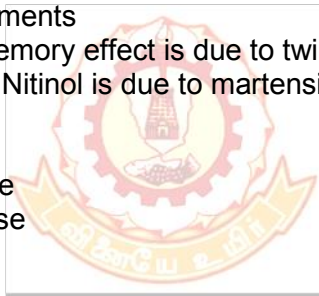

Concept Map

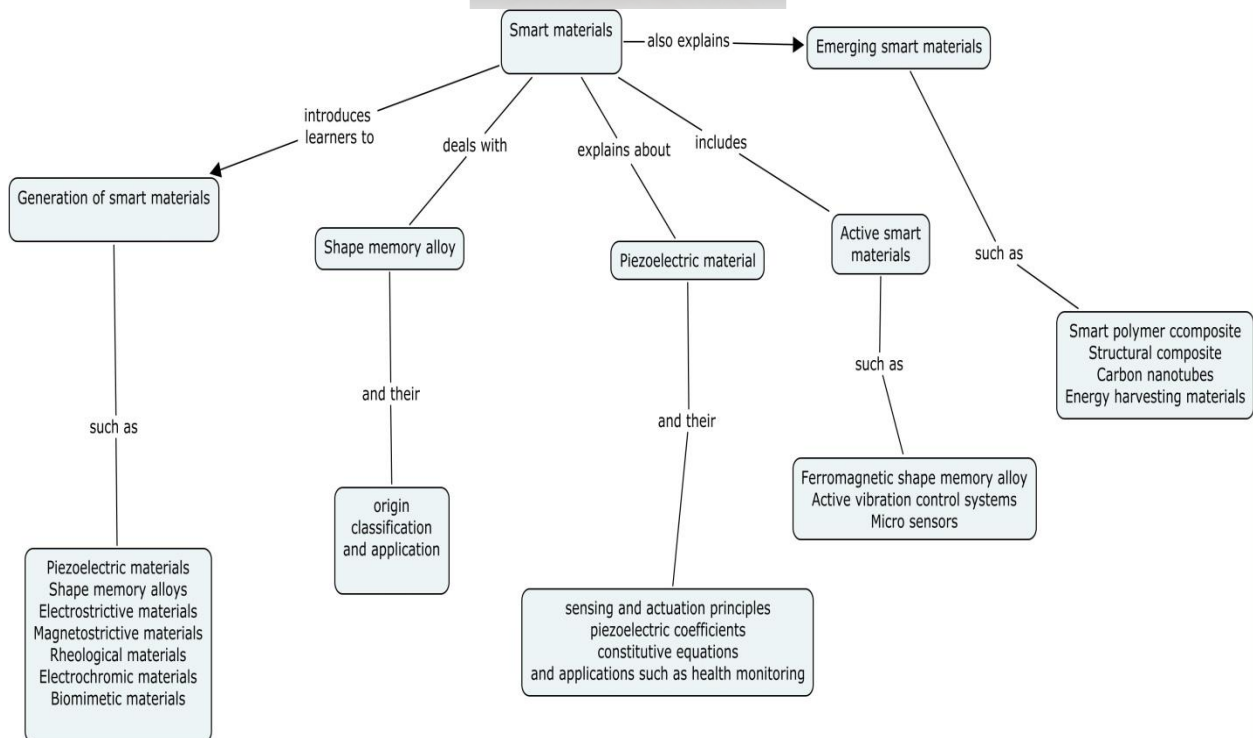

Syllabus

Overview of Smart Materials: Definition - Generation of Smart Materials - Piezoelectric Materials - Shape Memory Alloys - Electro/Magnetostrictive Materials - Electro/Magneto Rheological Materials - Electrochromic Materials - Biomimetic Materials - Comparison of the performances and limitations of various actuators (Numerical assessments).

Shape Memory Materials: Basics of Macro and Micro Mechanics -Origin of Shape Memory Alloy –Pseudoelasticity and Superelasticity – Types of Shape Memory Effect – Classes of SMAs- Fine Motion Systems; Automobiles, Trains, Medical and House Hold Devices.

Piezoelectric Materials: Sensing and Actuation Principles -Piezoelectricity and Materials – Piezoelectric Ceramics - Piezoelectric Coefficients – Constitutive Equations- Villari Effect - Matteuci Effect- Piezoelectric Sensors and Actuators in Positioning Devices- Structural Health Monitoring - Design of Piezo Stack Actuators for Smart Phones -Problems.

Active Smart Materials: Overview of Magnetic Materials - Joule Effect - Wiedemann Effect - Ferromagnetic Shape Memory Alloys -Magnetostrictive Materials - Constitutive Equations - Micro Sensors and Micro Actuators - Active Vibration Control Systems - Problems.

Emerging Smart Materials: Smart Polymer Composite Materials –Stress-Strain Behaviour of composites– Structural Composites – Carbon Nano Tubes - Energy Harvesting Materials – Intelligent Materials – Self-Sensing Polymers/ Electro Active Polymers

Text Books

1. M.V. Gandhi and B.S. Thompson, “**Smart Materials and Structures**”, Chapman & Hall UK, 1992
2. M. Kohl, “**Shape Memory Microactuators**”, Springer, New York, 2004
3. V.K. Wadhawan, “**Smart Structures**”, Oxford University Press, UK, 2007
4. V.K. Varadhan, K.J.Vinoy and S. Gopalakrishanan, Smart “**Materials and MEMS**”, John Wiley & Sons, UK, 2006
5. Ashwin Rao, A.R.Srinivasa and J. N. Reddy, “**Design of Shape Memory Actuators**”, Springer Cham Heidelberg, New York, 2015

Reference Books

1. Micky Rakotondrabe, “**Smart Materials- Based Actuators at Micro/Nano-Scale**”, Springer Science + Business Media, New York, 2013
2. Jan Fischer-Wolfarth and Gereon Meyer, “**Advanced Microsystems for Automotive Applications**”, Springer International Publishing, Switzerland, 2013
3. Mel Schwartz, “**Smart Materials**”, CRC Press New York, 2009
4. K. Otsuka and C.M. Wayman, “**Shape Memory Materials**”, Cambridge University Press , UK, 1998
5. Brian Culshaw, “**Smart Structures and Materials**”, Artech House, Boston, 2000.
6. William D. Callister, “**Materials Science and Engineering**”: An Introduction, Wiley, 2004

Course Contents and Lecture Schedule

Sl.No.	Topic	No. of Lectures
1	Overview of Smart Materials	
1.1	Generation of Smart Materials - Piezoelectric Materials - Shape Memory Alloys	2
1.2	Electrostrictive/Magnetostrictive Materials - Electro/Magneto Rheological Materials	2
1.3	Electrochromic Materials - Biomimetic Materials Comparison of the performances and limitations of various actuators (Numerical assessments)	2
2	Shape Memory Materials	
2.1	Basics of Macro and Micro Mechanics -Origin of Shape Memory Alloy	2
2.2	Pesudoelasticity and Superelasticity – Types of Shape Memory Effect , One-way and Two-way SME	3
2.3	Classes of SMAs: NiTi, Cu-based, Magnetic- based	1
2.4	Fine Motion Systems; Automobiles, Trains, Medical and House Hold Devices.	2
3	Piezoelectric Materials	
3.1	Sensing and Actuation Principles -Piezoelectricity and Materials – Piezoelectric Ceramics	3
3.2	Piezoelectric Coefficients – Constitutive Equations- Villari Effect - Matteuci Effect	3
3.3	Piezoelectric Sensors and Actuators in Positioning Devices- Structural Health Monitoring	2
3.4	Design of Piezo Stack Actuators for Smart Phones -Problems	2
4	Active Smart Materials	
4.1	Overview of Magnetic Materials - Joule Effect - Wiedemann Effect	2
4.2	Ferromagnetic Shape Memory Alloys -Magnetostrictive Materials - Constitutive Equations	2
4.3	Micro Sensors and Micro Actuators - Active Vibration Control Systems	1
4.4	Problems	1
5	Emerging Smart Materials	
5.1	Smart Polymer Composite Materials –Stress-Strain Behaviour of composites– Structural Composites	2
5.2	Carbon Nano Tubes - Energy Harvesting Materials	2
5.3	Intelligent Materials – Self-Sensing Polymers/Electro Active Polymers	2
Total Hours		36

Course Designers:

1. Dr. M.Mahendran. manickam-mahendran@tce.edu

14MTPH0**EMBEDDED SYSTEM**

Category L T P Credit

PE 3 0 0 3

Preamble

This course attempts to make the students familiar with modern embedded system involved in understanding CISC and RISC architecture, operating system and designing real-time based embedded systems. Unlike general purpose computing platforms, embedded systems must perform their tasks while minimizing tight resource constraints. CISC and RISC processors are embedded in products ranging from cell/mobile phones to automotive braking systems. The course begins by briefly noting the ARM7 and Cortex M processor, design philosophy and discussing how and why it differs from the traditional philosophy and also introduces embedded system based ARM7 and Cortex processor and also discusses the memory protection unit, and memory management unit.

Prerequisite

- 14MT570-Microcontrollers

Course Outcomes

On the successful completion of the course, students will be able to

CO1	List and describe the the RISC and CISC architecture	Understand
CO2	Distinguish between feature of ARM7 and cortex microcontroller	Understand
CO3	Illustrate the effectiveness of programming model in cortex M	Apply
CO4	Develop efficient coding for multiple interrupt handling	Apply
CO5	Design a control electronic system for industrial automation	Apply
CO6	Develop an embedded system for data acquisition and monitoring	Apply

Mapping with Programme Outcomes

COs	PO1	PO2	PO3	PO4	PO5	PO6	PO7	PO8	PO9	P10	P11	P12
CO1	S	M	L	-	-	-	-	-	-	-	-	-
CO2	S	M	L	-	-	-	-	-	-	-	-	-
CO3	S	M	M	-	M	-	-	-	M	-	-	M
CO4	S	M	M	-	M	-	-	-	M	-	-	M
CO5	S	M	M	-	M	-	-	-	M	--	-	M
CO6	S	S	S	-	M	-	-	-	M	-	-	M

S- Strong; M-Medium; L-Low

Assessment Pattern

Bloom's Category	Continuous Assessment Tests			Terminal Examination
	1	2	3	
Remember	20	20	20	20
Understand	40	40	40	40
Apply	40	40	40	40
Analyse	-	-	-	-
Evaluate	-	-	-	-
Create	-	-	-	-

Course Level Assessment Questions**Course Outcome 1 (CO1):**

1. Distinguish between RISC and CISC microcontroller.
2. List the ARM microcontrollers .
3. Define the functionality of CPU in microprocessor and microcontroller .
4. Distinguish between 16 bit and 32 bit microcontroller.

Course Outcome 2 (CO2)

1. Define the interrupts structure in ARM.
2. List the describe registers present in ARM.
3. Define the functionality of a serial peripheral in Cortex.
4. Show that how do you access the peripherals in ARM.

Course Outcome 3(CO3):

1. Demonstrate the timer peripheral in mode 1 operation.
2. Give an example for accessing serial peripheral in polling driven.
3. Describe the use of serial peripheral in asm programming .
4. Develop a C program for a described value of time delay .

Course Outcome 4 (CO4):

1. Demonstrate the timer peripherals with various modes .
2. Give an example for accessing timer in asm and C program.
3. Describe the functionality of the GPIO hardware for accessing IO device.
4. Distinguish between timer and counter in its modes of operation.

Course Outcome 5 (CO5):

1. Illustrate the serials peripherals for transmitting the data in defined baud rate .
2. Show the program for accessing an ADC and show it in LED display .
3. Demonstrate the operation of keyboard interfacing with Cortex board.
4. Construct the program for interfacing LCD module with Cortx board.

Course Outcome 6 (CO6):

1. Illustrate the ARM c program that how to handle interrupts for cortex board.
2. Show the c program for accessing a analog sensor and send the data to serial port .
3. Demonstrate the operation of c program for interfacing analog sensor with WIFI shield and make the system to IOT.
4. Construct the c program for accessing blue tooth for IOT application.

Concept Map

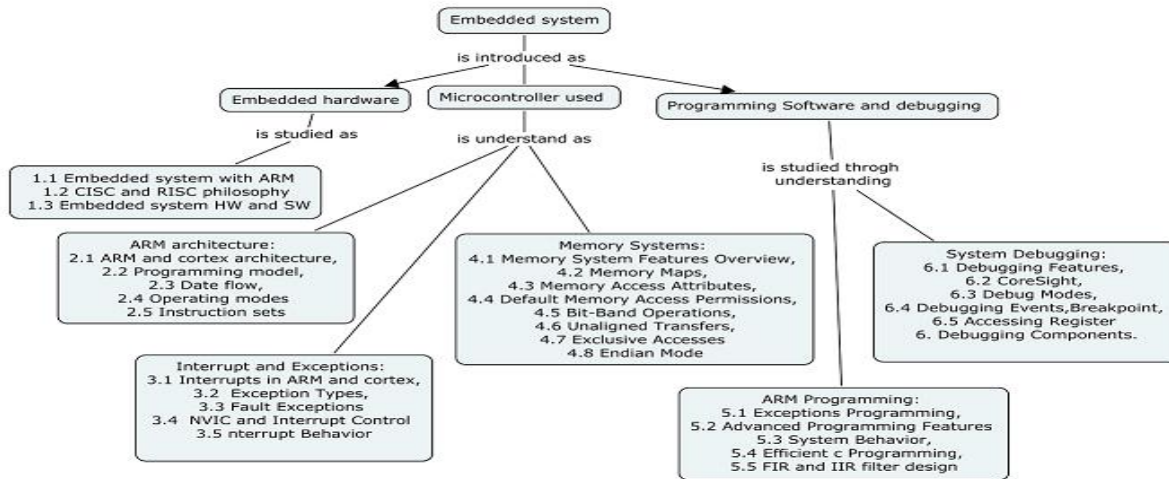

Syllabus

Embedded hardware: ARM Embedded system, CISC and RISC philosophy and Embedded system HW and SW.

ARM architecture: ARM and cortex architecture, Programming model, Date flow, Operating modes and Instruction sets

Interrupt and Exceptions: Interrupts in ARM and cortex, Exception Types, Fault Exceptions
The NVIC and Interrupt Control and Interrupt Behavior

Memory Systems: Memory System Features Overview, Memory Maps, Memory Access Attributes, Default Memory Access Permissions, Bit-Band Operations, Unaligned Transfers, Exclusive Accesses and Endian Mode

ARM Programming: Exceptions Programming, Advanced Programming Features and System Behavior, Efficient c Programming, Digital signal processing-FIR and IIR filter design

System Debugging: Debugging Features, CoreSight, Debug Modes, Debugging Events, Breakpoint, Accessing Register and Debugging Components.

Case study: Embedded system for monitoring, controlling and industrial automation

Text Books

1. Andrew N. Sloss Dominic Symes Chris Wright, "**ARM System Developer's Guide Designing and Optimizing System Software**", Elsevier Inc 2010
2. The Definitive Guide to the **ARM Cortex-M**" Joseph Yiu, Elsevier- Newness, 2014

Reference Books

1. Peter Barry Patrick **Crowley** "**Modern Embedded Computing Designing Connected, Pervasive, Media- Rich Systems**", Elsevier, 2012

Course Contents and Lecture Schedule

Sl.No.	Topic	No. of Lectures
1	Embedded system with ARM	
1.1	ARM Embedded system	1
1.2	CISC and RISC philosophy	1
1.3	Embedded system HW and SW	1
2	ARM architecture:	
2.1	ARM and cortex architecture	1
2.2	Programming model	1

2.3	Date flow	1
2.4	Operating modes	2
2.5	Instruction sets	1
3	Interrupt and Exceptions:	
3.1	Interrupts in ARM and cortex	1
3.2	Exception Types	2
3.3	Fault Exceptions	1
3.4	The NVIC and Interrupt Control	1
3.5	Interrupt Behavior	2
4	Memory Systems	
4.1	Memory System Features Overview	2
4.2	Memory Maps	2
4.3	Memory Access Attributes	1
4.4	Default Memory Access Permissions	1
4.5	Bit-Band Operations and Unaligned Transfers	1
4.6	Exclusive Accesses and Endian Mode	1
5	ARM Programming:	
5.1	Exceptions Programming	2
5.2	Advanced Programming Features and System Behavior	2
5.3	Efficient c Programming	2
5.4	Digital signal processing FIR and IIR filter design	2
6	System Debugging	
6.1	Debugging Features	1
6.2	CoreSight	1
6.3	Debug Modes	1
6.4	Debugging Events	1
6.5	Breakpoint	1
6.6	Accessing Register	1
6.7	Debugging Components	1
	Total	39

Course Designers:

- | | | |
|----|------------------|-------------------------|
| 1. | Dr.L.R.Karl Marx | lkarlmarx@tce.edu |
| 2. | S.Parthasarathi | Parthasarathi_s@tce.edu |

14MTPJ0

**PROGRAMMING FOR ROBOTIC
SYSTEM**

Category	L	T	P	Credit
PE	3	0	0	3

Preamble

Robot Programming is the set of coded commands or instructions that tell a mechanical device and electronic system, known together as a robot, about performing the tasks. Robot Programming is used to perform autonomous tasks. Many software systems and frameworks have been proposed to make programming robots easier. Common tasks include feedback loops, control, path finding, data filtering, and locating. The Purpose of this course is used to create intelligent mechanical system.

Prerequisite

- 14MT320 - Kinematics and Dynamics of Machines
- 14MT370 - Problem Solving using Computer
- 14MT620 - Robotics

Course Outcomes

On successful completion of the course, students will be able to

CO1.	Explain the concepts of Python, ROS and open CV.	Understand
CO2.	Explain syntax used in different programming language.	Understand
CO3.	Solve hardware interfacing problems using various programming language codes.	Apply
CO4.	Develop innovative problem-solving skills for various industrial application	Create

Mapping with Programme Outcomes

COs	PO1	PO2	PO3	PO4	PO5	PO6	PO7	PO8	PO9	PO10	PO11	PO12
CO1.	S	M	S	M	-	-	-	-	L	-	-	-
CO2.	S	M	M	L	-	-	-	-	L	-	-	-
CO3.	S	L	M	L	-	-	-	-	L	-	-	-
CO4.	S	M	M	M	-	-	-	-	L	-	-	-

S- Strong; M-Medium; L-Low

Assessment Pattern

Bloom's Category	Continuous Assessment Tests			Terminal Examination
	1	2	3	
Remember	20	20	20	20
Understand	30	30	30	30
Apply	20	20	20	20
Analyse	-	-	-	-
Evaluate	-	-	-	-
Create	-	-	-	-

Course Level Assessment Questions

Course outcome 1:

1. Explain the various robot configurations with neat sketches.
2. Explain various Robot programming methods.
3. Explain the application of robots in welding.

Course outcome 2:

1. Describe the syntax used to control servo drive in mobile robots.
2. Write the python code for sensor interface.
3. Explain the kinetic programming in ROS.

Course outcome 3:

1. A moving frame is rotated about a fixed frame in the following manner,
 - i) Rotation of 90° about U.
 - ii) Rotation of 1800° about Z.
 - iii) Rotation of 90° about Y.
 - iv) Rotation of -90° about X.
 - v) Rotation of 90° about V.
 - vi) Rotation of -90° about U.

A point has co ordinates (15,-27, and 38) with respect to moving frame. Map the point in the fixed frame.

2. Write various technical features required of robot for spot welding and spray coating applications.

Course outcome 4:

1. Create a robot and coding for detecting cracks in canal or pipes.
2. Create a open CV for operate welding simulator manufacturing industries.

Concept Map

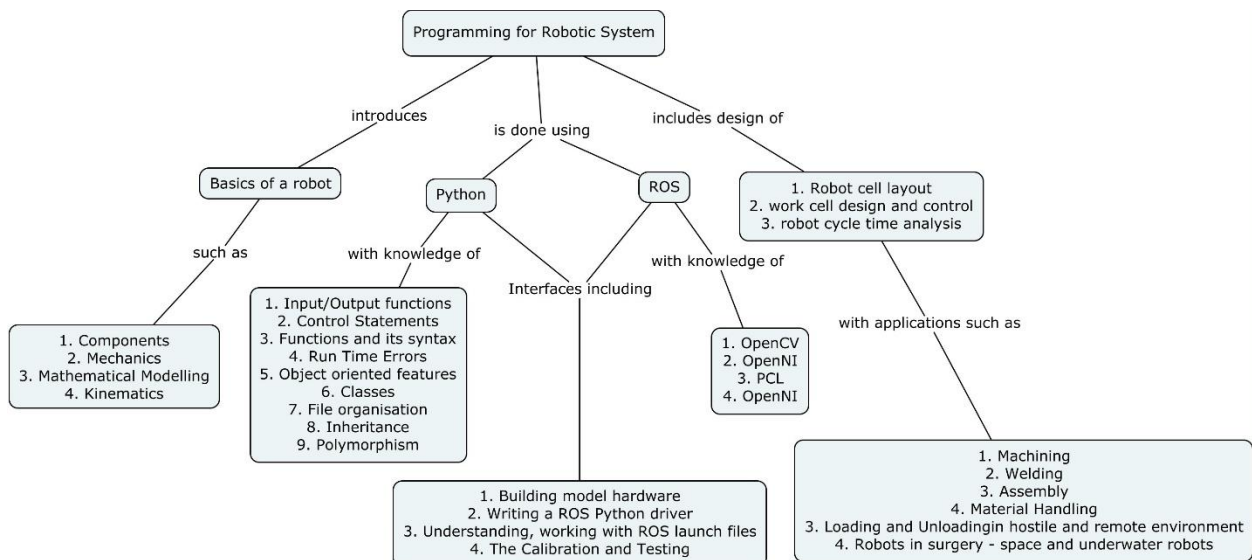

Syllabus

Introduction: History – Definition – Components – Building a robot – The Robot drive mechanism- Mathematical modeling of the robot - Robot kinematics.

Programming in python: Introduction about python- input and output functions – control statement- Functions and its syntax- Run Time Errors - Exception Model - Exception Hierarchy- Object oriented features – Classes- instance method- file organisation- inheritance – polymorphism.

ROS: Introduction to OpenCV, OpenNI, and PCL - Programming Kinect with Python using ROS, OpenCV, and OpenNI - Working with Point Clouds using Kinect, ROS, OpenNI, and PCL.

Interfacing ROS using python: Building model hardware - Writing a ROS Python driver - Understanding ROS launch files - Working with Python nodes and launch files - The Calibration and Testing - The Calibration of Xbox Kinect using ROS - Wheel odometry calibration - Testing of the robot using GUI.

Robot Application: Robot cell layout - work cell design and control- robot cycle time analysis- Applications: Machining - Welding - Assembly - Material Handling - Loading and Unloading in hostile and remote environment. Robots in surgery- space and underwater robot.

Programming Problems: Motor control using Python programming - Servo position control using python- vision programming using python- 3D work space design using ROS.

Text Book

1. Mark Summerfield —**Programming in Python 3: A Complete introduction to the Python Language**, Addison-Wesley Professional, 2009.
2. Aaron Martinez and Enrique Fernandez, —**Learning ROS for Robotics Programming**, PACKT Publishing, 2013.

Reference Books

1. Wesley J Chun, —**Core Python Applications Programming**, Prentice Hall, 2012.
2. Allen B Downey, —**Think Python**, O'Reilly, 2012.
3. Bill Smart, Brian Gerkey, Morgan Quigley, —**Programming Robots with ROS: A Practical Introduction to the Robot Operating System**, O'Reilly Publishers, 2015.

Course Contents and Lecture Schedule

S.No.	Topic	No. of Lectures
1	Introduction:	
1.1	History – Definition – Components – Building a robot	2
1.2	The Robot drive mechanism- Mathematical modeling of the robot	1
1.3	Robot kinematics.	2

14MTPK0 INDUSTRIAL INTERNET OF THINGS

Category	L	T	P	Credit
PE	3	0	0	3

Preamble

The humans in the past have used the Internet to communicate while generating ever-increasing amounts of data, there now must be added devices and machines that also are capable of transferring very large data volumes into the network. All of the leading experts are now of the opinion that in future the data fed into the Internet by “things” will make up a greater proportion of the data circulating there than the information and data input by humans.

In the current definition, Industry 4.0 is only concerned with a part of IoT, namely that part that affects the manufacturing industry. Even although one can assume that the manufacturing industry will distribute large amounts of data over the Internet, it will still only represent a fraction of the entire data volume present there. Make-to-order manufacturing and just-in-time delivery to the customer are becoming decisive competitive factors for more and more industries. This development has for quite some time not only affected the manufacturers of consumer goods, but also the automobile industry, aerospace and the manufacturers of certain types of machines, plant and components. Mass customization is expected almost everywhere, as are individual products manufactured at speed but at mass-manufacturing costs. These market requirements and the resulting competitive pressure means that manufacturing companies are faced with unprecedented challenges. The fast-approaching up heaval can therefore be better seen as a revolution – in this case the Fourth Industrial Revolution.

Prerequisite

- 14MT330 - Sensors and PLC
- 14MT570 - Microcontrollers

Course Outcomes

On the successful completion of the course, students will be able to,

CO 1.	Explain various technology used in IIOT and its applications	Understand
CO 2.	Discuss different protocols used in IOT	Understand
CO 3.	Design a Industrial Internet system	Apply
CO 4.	Develop a Industry 4.0 Smart factories	Apply

Mapping with Programme Outcomes

Cos	PO1	PO2	PO3	PO4	PO5	PO6	PO7	PO8	PO9	PO10	PO11	PO12
CO1.	S	M	-	-	-	-	-	-	-	-	-	-
CO2.	S	M	-	-	M	L	-	-	-	-	-	L
CO3.	S	M	M	-	-	L	-	-	-	-	-	-
CO4.	S	M	-	S	M	L	-	-	-	-	-	M

S- Strong; M-Medium; L-Low

Assessment Pattern

Bloom's Category	Continuous Assessment Tests			Terminal Examination
	1	2	3	
Remember	20	20	20	20
Understand	60	60	40	40
Apply	0	20	40	40
Analyse	-	-	-	-
Evaluate	-	-	-	-
Create	-	-	-	-

Course Level Assessment Questions**Course Outcome 1 (CO1):**

- 1.Explain the Application of IIOT
- 2.Define Industrial Internet.
- 3.Explain network function virtualization.
- 4.Explain the applications of M2M learning in IIOT.

Course outcome 2 (CO2)

- 1.Distinguish M2M and IIOT architecture.
- 2.Explain IIC reference architecture.
- 3.Explain three tier topology of IIOT.
- 4.Brief about advanced Data Analytics.

Course Outcome 3 (CO3):

- 1.Design a IIOT platform for a CIM system.
- 2.Design a IIOT system for a SMART grid.
- 3.Select and explain a suitable protocol for vehicle charging system.
4. Explain IIOT WAN Technologies and protocols.

Course Outcome 4 (CO4):

1. Explain the characteristics of Industry 4.0
2. Develop a Smart factory for manufacturing automobile parts.
3. Explain the characteristics of Industry 4.0.
4. Automate the water filling plant using IIOT concept.

Concept Map

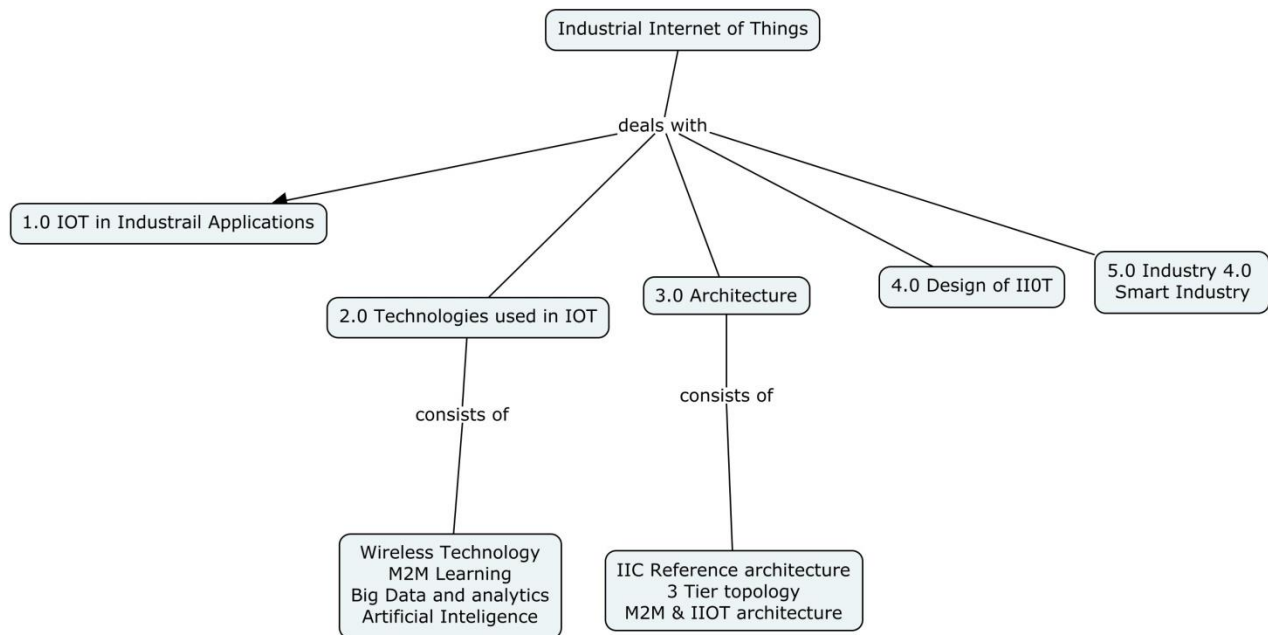

Syllabus

Introduction to the industrial Internet

Horizontal and vertical aspects of IOT – Definition of Industrial Internet – Power of I% - need for industrial internet – Catalysts and precursors of the IOT – opportunity and benefits – applications of industrial internet – health care, oil and Gas industry, smart office, logistics, retail.

Technical innovations of industrial internet

Minimization – cyber physical systems(CPS) – wireless technology – IP mobility – network functionality virtualization (WFV) – Network virtualization – software defined network (SDN) – smart phones – The cloud and fog – Big data and analytics – M2M learning and artificial intelligence – augmented reality – 3Dprinting.

IIoT Architecture

M2M and IIoT architecture – IIC Reference Architecture – Industrial Internet architecture framework – functional, control, operational, information, application, business domain – architecture topology – three tier topology – gateway mediated edge – connectivity – key system characteristics, functional characteristics, function of communication layer – Data management – Query, Storage, persistence, Retrieval, Advanced data analytics.

Designing Industrial internet systems.

Designing low power device network – industrial protocols – modern communication protocols – wireless communication technologies – proximity network communication protocols – middle wave transport protocols – middle wave software patterns – software design concept –

middle wave industrial internet of things platform – IIOT WAN technology and protocols – securing the industrial internet, Case study-Electric vehicle Charging

Introduction to industry 4.0

Defining industry 4.0 – need – characteristics of industry 4.0 – value chain – benefits of – Design principles building blocks of industry 4.0 – reference architecture – smart factories – smart grid – industry 4.0 business models.

Text Books

1. Alasdair Gilchrist “**Industry 4.0 industrial internet**“, Aprcas publications 2016
2. Oliviver Hersent, David Boswarthink Omar Elloumi “**The internet of things**” – WILEY Publications 2012.

Reference Books

1. Dieter Uckelmann, Mark Harrison, Florian Michahelles, “**Architecting the Internet of Things**”, Springer, 2011
2. Donald Norris, “**The Internet of Things: Do-It-Yourself at Home Projects for Arduino, Raspberry Pi and BeagleBone Black**”, Mc.Graw Hill, 2015.
3. Cuno Pfister, “**Getting Started with the Internet of Things**”, O'Reilly Media, Inc., 2011

Course contents and Lecture schedule

Sl.No	Topic	No. of Lectures
1.0	Introduction to the industrial Internet	
1.1	Horizontal and vertical aspects of IOT- Definition of Industrial Internet	1
1.2	Power of I% -need for industrial internet- Catalysts and precursors of the IOT	1
1.3	Opportunity and benefits- applications of industrial internet- health care, oil and Gas industry, smart office, logistics, retail	2
2.0	Technical innovations of industrial internet	
2.1	Minimization-cyber physical systems(CPS)- wireless technology	1
2.2	IP mobility-network functionality virtualization (WFV)-Network virtualization	2
2.3	Software defined network (SDN) -smart phones-Re cloud and fog	1
2.4	Big data and analytics-M2M learning and artificial intelligence	2
2.5	Augmented reality-3Dprinting.	1
3.0	IIOT Architecture	

Sl.No	Topic	No. of Lectures
3.1	M2M and IIOT architecture- IIC Reference Architecture	2
3.2	Industrial Internet architecture framework -functional, control, operational, information, application, business domain	2
3.3	Architecture topology- three tier topology- gateway mediated edge	2
3.4	Connectivity- key system characteristics, functional characteristics, function of communication layer- Data management	1
3.5	Query, Storage persistence, Retrieval, Advanced data analytics	1
4.0	Designing Industrial internet systems.	
4.1	Designing low power device network- industrial protocols	1
4.2	Modern communication protocols-wireless communication technologies	2
4.3	Proximity network communication protocols- Middle wave transport protocols	1
4.4	Middle wave software patterns- software design concept- Middle wave industrial internet of things platform	2
4.5	IIR WAN technology and protocols- securing the industrial internet.	1
4.6	Electric Vehicle Charging –case study	2
5.0	Introduction to industry 4.0	
5.1	Defining industry 4.0- need and characteristics of industry 4.0- value chain.	1
5.2	Design principles building blocks of industry 4.0- reference architecture	1
5.3	Smart factories	2
5.4	Smart grid	2
5.5	Industry 4.0 business models.	1
TOTAL		36

Course Designers:

1.H.Ramesh
2.M.Manimegalen

rameshh@tce.edu
mmmech@tce.edu

14MTPM0**INDUSTRIAL COMMUNICATION
NETWORKS**

Category	L	T	P	Credit
PE	3	0	0	3

Preamble

Data communication is the transfer of information from one point to another. Modern instrumentation and automation systems are almost wholly concerned with the transfer of digital data. In the past decade many standards and protocols have been established which allow data communications technology to be used more effectively in industry. Designers and users are beginning to realize the tremendous economic and productivity gains possible with the integration of discrete systems through networks. Protocols are the structures used within a communication system so that one device can talk to another device. Traditionally developers of software and hardware platforms have developed protocols, which only their products can use. In order to develop more integrated automation systems, standardisation of these communication protocols is required.

Standards may evolve from the wide use of one manufacturer's protocol or may be specifically developed by bodies that represent an industry. Standards allow manufacturers to develop products that will communicate with equipment already in use, which for the customer simplifies the integration of products from different sources.

Prerequisite

NIL

Course Outcomes

On the successful completion of the course, students will be able to,

CO 1.	Explain the operation, characteristics and performance of different data networks	Understand
CO 2.	Identify different cables, connectors and network connecting devices available in the market for data communication.	Understand
CO 3.	Discuss development of different communication protocols in industries for interconnecting automation systems.	Understand
CO 4.	Choose appropriate communication network for given industrial applications.	Apply

Mapping with Programme Outcomes

COs	PO1	PO2	PO3	PO4	PO5	PO6	PO7	PO8	PO9	PO10	PO11	PO12
CO1.	M	M	M	S	M	M	-	M	M	-	-	S
CO2.	M	M	S	S	M	M	-	M	S	S	M	S
CO3.	S	S	S	S	S	S	S	S	S	S	M	S
CO4.	S	S	S	S	S	S	S	S	S	S	M	S

S- Strong; M-Medium; L-Low

Assessment Pattern

Bloom's Category	Continuous Assessment Tests			Terminal Examination
	1	2	3	
Remember	20	20	20	20
Understand	80	80	50	60
Apply	-	-	30	20
Analyse	-	-	-	-
Evaluate	-	-	-	-
Create	-	-	-	-

Course Level Assessment Questions

Course Outcome 1 (CO1):

1. Explain different network topologies of data communication.
2. Explain OSI model for network communication
3. Classify the network on the basis of scale.
4. Explain the components of computer networks.

Course Outcome 2 (CO2):

1. Differentiate RS-232 and RS-485 standards for data communication.
2. List out the advantages of using optical fibre cable for data communication.
3. Explain different types of connectors used for data communication.
4. Explain various network connecting devices.

Course Outcome 3 (CO3):

1. Explain the OSI model of TCP/IP protocol.
2. Explain Profibus communication model.
3. Explain the foundation field bus protocol.
4. Explain Profibus protocol stack.

Course Outcome 4 (CO4):

1. Design a suitable network layout for connecting Siemens PLC with mitshubishi VFD in master/slave configuration.
2. Select and explain the communication protocol for interconnecting pick and place robot , CNC controller ,ASRS system and conveyor in an automated work cell.
3. Design the layout and protocol for connecting multiple robots in a wireless network.
4. Design a network for connecting measuring instruments in DCS system

Concept Map

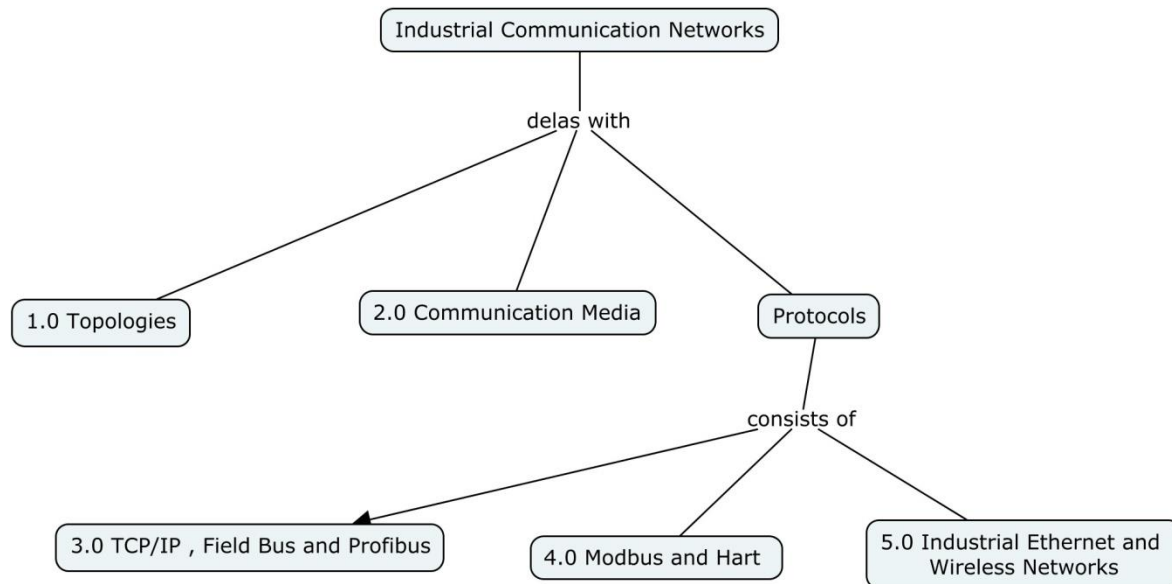

Syllabus

Data Network Fundamentals

Data networks in Modern Instrumentation and automation systems -Components of Computer Networks: hardware and software -Network topologies: Star, Ring, Bus, Mesh -Network Classification Based on Transmission Technologies: Point-to-point, broadcast -Based on scale: LAN, WAN, MAN,VPN, Internet -Based on Architecture: Peer to Peer, Client Server, advantages of Client Sever over Peer-to-Peer Model -OSI Model

Network communication Media

Overview of RS-232,RS-485standards-Transmission Media: Unguided and Guided media, Wired and Wireless, UTP, Coaxial and Fiber optical cable -Types of Connectors: RJ-45, RJ-11, BNC, BNC –T, BNC Terminator, Fiber optic connectors:- Subscriber Channel(SC), Straight Tip(ST), Mechanical transfer – registered jack(MT-RJ) connectors -Network Interface Card (NIC), ARCNET, Ethernet. Network connecting devices: Repeater, Hub, Bridge, Switch , Router, Gateway, Access point, Wireless Access points.

TCP/IP , Field Bus and Profibus

TCP/IP:OSI model, Internet layer protocol, Host to Host layer Field Bus: Features, wiring rules, Data link layer, application layer, user layer Profibus : features- Profibus protocol stack-Profibus communication model-relationship between application process and communication-communication objects-system operation

Modbus and Hart

Modbus: general overview, Modbus protocol structure, Function codes. Hart: Hart and smart instrumentation, Hart protocol, physical layer, data link layer, application layer.

Industrial Ethernet and Wireless Networks

Industrial Ethernet: overview, 10 Mbps ,100 Mbps, Gigabit-design considerations ,recent developments in industrial Ethernet. Wireless Networks: Topology, Standards, WLAN, WPAN, Industrial Automation requirements, Application of wireless network for industrial automation, Basics of Industry 4.0.

Text Books

1. Practical Industrial Data Networks -Design, Installation, trouble shooting, Steve Mackay **Edwin Wright MIPENZ**, Deon Reynders, John Park, IDC Technologies, Australia 2014.
2. **Wireless Networks for Industrial Automation** 4th Edition by Dick Caro , The Instrumentation, Systems, Automation Society 2016.

Reference Books

1. Deon Reynders, Steve Mackay, Edwin Wright **“Practical Industrial data communications”** ,ELSEVIER 2012.
2. John park and Steve Mackay **“Data acquisition for Instrumentation and control systems”** by, IDC Technologies 2003.

Course contents and Lecture schedule

Sl.No	Topic	No. of Lectures
1.0	Data Network Fundamentals	
1.1	Data networks in Modern Instrumentation and automation systems - Components of Computer Networks: hardware and software	2
1.2	Network topology, Network Classification	2
1.3	OSI Model	1
2.0	Network communication Media	
2.1	Overview of RS-232,RS-485standards	2
2.2	Transmission Media	2
2.3	Types of connectors	1
2.4	Network connecting devices	2
3.0	TCP/IP , Field Bus and Profibus	
3.1	TCP/IP:OSI model, Internet layer protocol, Host to Host layer	2
3.2	Field Bus: Features, wiring rules, Data link layer, application layer, user layer	2
3.3	Profibus : features- Profibus protocol stack-Profibus communication model	2
3.4	relationship between application process and communication-	2

Sl.No	Topic	No. of Lectures
	communication objects-system operation	
4.0	Modbus and Hart	
4.1	Modbus: general overview, Modbus protocol structure, Function codes	2
4.2	Hart: Hart and smart instrumentation	2
4.3	Hart protocol, physical layer, data link layer, application layer	2
5.0	Industrial Ethernet and Wireless Networks	
5.1	Industrial Ethernet: overview, 10 Mbps ,100 Mbps, Gigabit	2
5.2	Design considerations	1
5.3	Recent developments in industrial Ethernet.	1
5.4	Wireless Networks: Topology, Standards	2
5.5	WLAN, WPAN	2
5.6	Industrial Automation requirements	1
5.7	Application of wireless network for industrial automation	1
5.8	Basics of Industry 4.0	2
TOTAL		36

Course Designers:

- | | | |
|----|-----------------------|-----------------|
| 1. | Dr. G.S.R.Emil Selvan | emil@tce.edu |
| 2. | Mr.H. Ramesh | rameshh@tce.edu |

14MTPN0 AUTOMOTIVE MECHATRONICS

Category	L	T	P	Credit
PE	3	0	0	3

Preamble

Automotive Mechatronics is a discipline that involves multidisciplinary integration of automotive mechanical and electronic systems. It includes automotive-specific mechanics, electronics, and communication, advanced control and modelling. The subject deals with all the aspects of automotive Mechatronics, especially in transmission, braking, steering, cruise, traction, suspension and stability. Some of the main applications of Mechatronics are introduced. The students would be able to understand the basic dynamics and develop the equations according to the vehicle conditions.

Prerequisite

- 14MT440 - Metrology and Measurements
- 14MT230 - Electrical machines
- 14MT450 - Fluid Power Automation

Course Outcomes

On successful completion of the course, students will be able to

CO 1	Identify basic automotive mechatronic systems	Understand
CO 2	Explain transmission control, Cruise Control and Engine control system dynamics.	Understand
CO 3	Illustrate braking control Traction Control and Suspension Control dynamics.	Apply
CO4	Solve the Stability Control, Steering control dynamics	Apply

Mapping with Programme Outcomes

COs	PO1	PO2	PO3	PO4	PO5	PO6	PO7	PO8	PO9	P10	P11	P12
CO1	M	M	S	S	-	-	S	-	-	M	L	S
CO2	M	L	S	S	-	S	-	-	-	M	L	S
CO3	M	S	L	M	M	M	-	-	-	L	L	M
CO4	S	S	M	S	M	S	S	-	-	M	M	M

S- Strong; M-Medium; L-Low

Assessment Pattern

Bloom's Category	Continuous Assessment Tests			Terminal Examination
	1	2	3	
Remember	20	20	20	20
Understand	80	80	80	80
Apply	-	-	-	-
Analyse	-	-	-	-
Evaluate	-	-	-	-
Create	-	-	-	-

Course Level Assessment Questions**Course Outcome 1 (CO1):**

1. Explain the function of Air Bags.
2. Describe the working of TPMS.
3. State the basic principle of automatic headlight control
4. Describe the mechanisms of folding roofs.
5. Draw the mechanism of wiper control.

**Course Outcome 2(CO2):**

1. Explain the components behind Automatic Transmission
2. List the Control Modes and describe the Mechanism of transmission control.
3. Explain the working of Mechatronic Gear Shift
4. Identify the need of Cruise control.
5. Report the effect of engine control affect the performance of the vehicle
6. Discuss the difference between Adaptive and Automatic cruise control.
7. Draw the architecture of cruise controller.
8. Explain the common failsafe circuit of cruise control.

Course Outcome 3 (CO3):

1. Describe the forces affecting wheel traction. Avoid negligible forces and derive an equation.
2. Derive the vehicle dynamics equations during braking
3. Describe the purpose of ABS system. How is it different from conventional braking.
4. Explain the suspension control dynamics for hydro pneumatic suspension system

Course Outcome 4 (CO4):

1. List the different types of stability controllers.
2. Describe the function of Vehicle Dynamics Controller.
3. Explain VDC Safety Concept. Draw the architecture and discuss.

4. Review the function of Four Wheel Steering Systems.

Concept Map

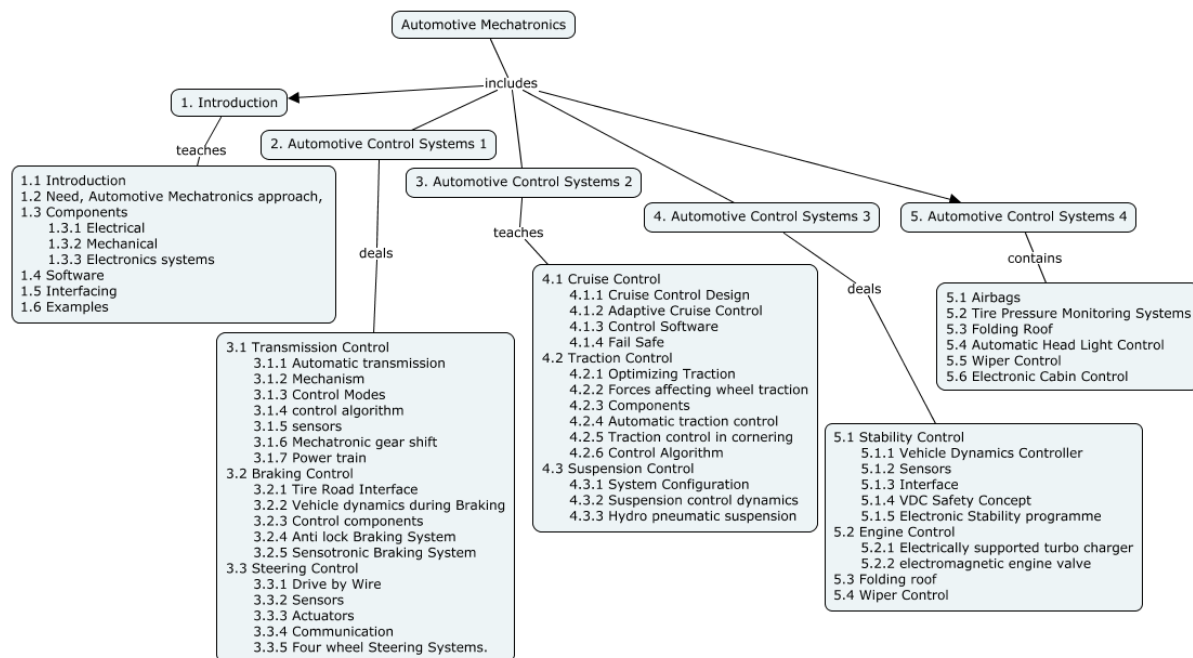

Syllabus

Introduction to Automotive Mechatronics Introduction, Need, Automotive Mechatronics approach, Components-Electrical, Mechanical, Electronics systems, Software, Interfacing. Examples.

Automotive Systems I Transmission Control – Automatic transmission – Mechanism – Control Modes - control algorithm – sensors - Mechatronic gear shift – Power train, Braking Control– Tire Road Interface – Vehicle dynamics during Braking - Control components – Anti lock Braking System – Sensotronic Braking System, Steering Control– Drive by Wire – Sensors – Actuators – Communication – Four wheel Steering Systems.

Automotive Systems II Cruise Control – Cruise Control Design - Adaptive Cruise Control – Control Software – Fail Safe, Traction Control - Optimizing Traction – Forces affecting wheel traction - Components– Automatic traction control - Traction control in cornering - Control Algorithm, Suspension Control - System Configuration – suspension control dynamics – Hydro pneumatic suspension control system.

Automotive systems III Stability Control – Vehicle Dynamics Controller – Sensors – Interface - VDC Safety Concept - Electronic Stability programme (ESP), Engine Control - Electrically supported turbo charger - electromagnetic engine valve

Automotive Systems IV Airbags, Tire pressure monitoring systems, Automatic head light control, Folding roof, Wiper Control, Electronic Cabin control

Text Books

1. Uwe Kiencke, Lars Nielsen, "**Automotive Control Systems**", by Springer second edition, 2005.
2. Ronald K Jurgen, "**Automotive Electronics**", by McGraw Hill, second edition. (Original edition- 1999).

Reference Books

1. Robert K Bishop, "**Mechatronics Handbook**", CRC Press, 2002.
2. Rolf Isermann, "Mechatronics Systems: Fundamentals", Springer 2005.
3. Bosch Professional Automotive Information, "**Automotive Mechatronics: Automotive Networking, Driving Stability Systems, Electronics**" published by Springer in 2014.

Course Contents and Lecture Schedule

Sl. No.	Topic	No. of Lectures
1	Introduction to Automotive Mechatronics	
1.1	Introduction, Need	1
1.2	Automotive Mechatronics approach, Components-Electrical, Mechanical	1
1.3	Electronics systems, Software, Interfacing	1
1.4	Examples	1
2	Automotive Systems 1	
2.1	Transmission Control – Automatic transmission – Mechanism	1
2.2	Control Modes - control algorithm	1
2.3	Sensors - Mechatronic gear shift— Power train	1
2.4	Braking Control– Tire Road Interface	1
2.5	Vehicle dynamics during Braking	1
2.6	Control components – Anti lock Braking System	1
2.7	Sensotronic Braking System	1
2.8	Steering Control– Drive by Wire	1
2.9	Sensors	1
2.10	Actuators	1
2.11	Communication – Four wheel Steering Systems.	1
3	Automotive Systems 2	
3.1	Cruise Control – Cruise Control Design	1
3.2	Adaptive Cruise Control – Control Software	1
3.3	Fail Safe	1
3.4	Traction Control - Optimizing Traction – Forces affecting wheel	1

Sl. No.	Topic	No. of Lectures
	traction	
3.5	Components– Automatic traction control	1
3.6	Traction control in cornering - Control Algorithm	1
3.7	Suspension Control - System Configuration	1
3.8	Suspension control dynamics	1
3.9	Hydro pneumatic suspension control system	1
4	Automotive Systems 3	
4.1	Stability Control – Vehicle Dynamics Controller	1
4.2	Sensors – Interface	1
4.3	VDC Safety Concept	1
4.4	Electronic Stability programme (ESP)	1
4.5	Engine Control - Electrically supported turbo charger - electromagnetic engine valve	1
5	Automotive Systems 4	
5.1	Airbags	1
5.2	Tire pressure monitoring systems	1
5.3	Automatic head light control	1
5.4	Folding roof	1
5.5	Wiper Control	1
5.6	Electronic Cabin control	1
Total Hours		35

Course Designers:

- | | | |
|------------------|---|----------------------|
| 1. Mr T Vivek | - | tvivek@tce.edu |
| 2. Mr M.A Ganesh | - | ganeshma2015@tce.edu |

14MTPP0**ARTIFICIAL INTELLIGENCE**

Category	L	T	P	Credit
PE	3	0	0	3

Preamble

AI is a branch of computing science that deals with the specification, design and implementation of information systems that have some knowledge related to the enterprise in which the information systems are situated. The term intelligent systems tends to provoke and enthuse people in almost equal numbers during the 1970's and 1980's. The current vogue term is conscious systems or systems that can consciously determine what to learn and how to deploy the learnt knowledge. However, there are sub-disciplines of artificial intelligence that are providing solutions to problems of the so-called information age; the age of world-wide webs, of intelligent crawlers, of knowledge discovery and data mining, of fuzzy control, of autonomous learning systems and of distributed artificial intelligent systems. AI deals with the timely, relevant and accurate exchange of information between humans and computers. The AI course will deal issues related to the development of intelligent information systems and will focus on five major topic areas:

- Knowledge-based Expert Systems
- Knowledge Representation
- Knowledge Acquisition and Machine Learning
- Natural Language Processing Systems
- Fuzzy Logic and Fuzzy Control Expert Systems.

Prerequisite

- Nil

Course Outcomes

On the successful completion of the course, students will be able to

CO1	Ability to adhere Different AI concepts and its need in problem solving.	Understand
CO2	Learning Fuzzy logic, its orientation to AI and Implementation using python programming language.	Understand
CO3	Illustrate the working of Neural networks and its different learning techniques.	Apply
CO4	Providing solutions using different types of genetic algorithms for optimization and implementation using High level languages.	Apply
CO5	: Developing knowledge on different opensource AI tools for using Python programming language	Apply

Mapping with Programme Outcomes

COs	PO1	PO2	PO3	PO4	PO5	PO6	PO7	PO8	PO9	P10	P11	P12
CO1	S	L	S	-	-	-	-	-	-	-	-	-
CO2	S	L	S	L	-	-	M	-	-	M	-	-
CO3	M	L	S	L	-	-	-	-	-	-	-	-
CO4	M	M	M	-	M	M	-	M	-	L	-	M
CO5	S	L	S	L	-	-	-	-	-	-	-	-

S- Strong; M-Medium; L-Low

Assessment Pattern

Bloom's Category	Continuous Assessment Tests			Terminal Examination
	1	2	3	
Remember	40	40	40	40
Understand	30	30	30	30
Apply	30	30	30	30
Analyse	-	-	-	-
Evaluate	-	-	-	-
Create	-	-	-	-

Course Level Assessment Questions**Course Outcome 1 (CO1):**

- 1.What is a Knowledge Based System?
- 2.Analyse the logic behind– Hill climbing, Best-First Search, BFS and DFS
- 3.Describe the four categories under which AI is classified with
- 4.Discuss FOL with an examples

Course Outcome 2 (CO2):

1. Explain Fuzzy union, fuzzy intersection and fuzzy complement
2. Discuss about Membership function.
3. elaborate about convex fuzzy set.
4. Explain Fuzzy set Theory and differentiate it from Crisp set theory.

Course Outcome 3(CO3):

1. illustrate the working of perceptron.
2. Develop a neural network for implementation of and gate.
3. Differentiate supervised and Unsupervised Learning.
4. Explain about Sigmoidal function
5. Define Back propagation network.

Course Outcome 4 (CO4):

1. Explain important characteristics of expert systems.
2. List out components of expert systems.
3. Define the terms knowledge base, inference systems.
4. Differentiate Expert systems vs Conventional programs

Course Outcome 5 (CO5):

1. Write a basic python program for implementing simple AI.
2. Write a simple fuzzy logic using scikit-fuzzy toolbox.
3. Develop a neural network for realising a simple digital LOGIC function.
4. Explain how fitness function influences the genetic algorithm

Concept Map

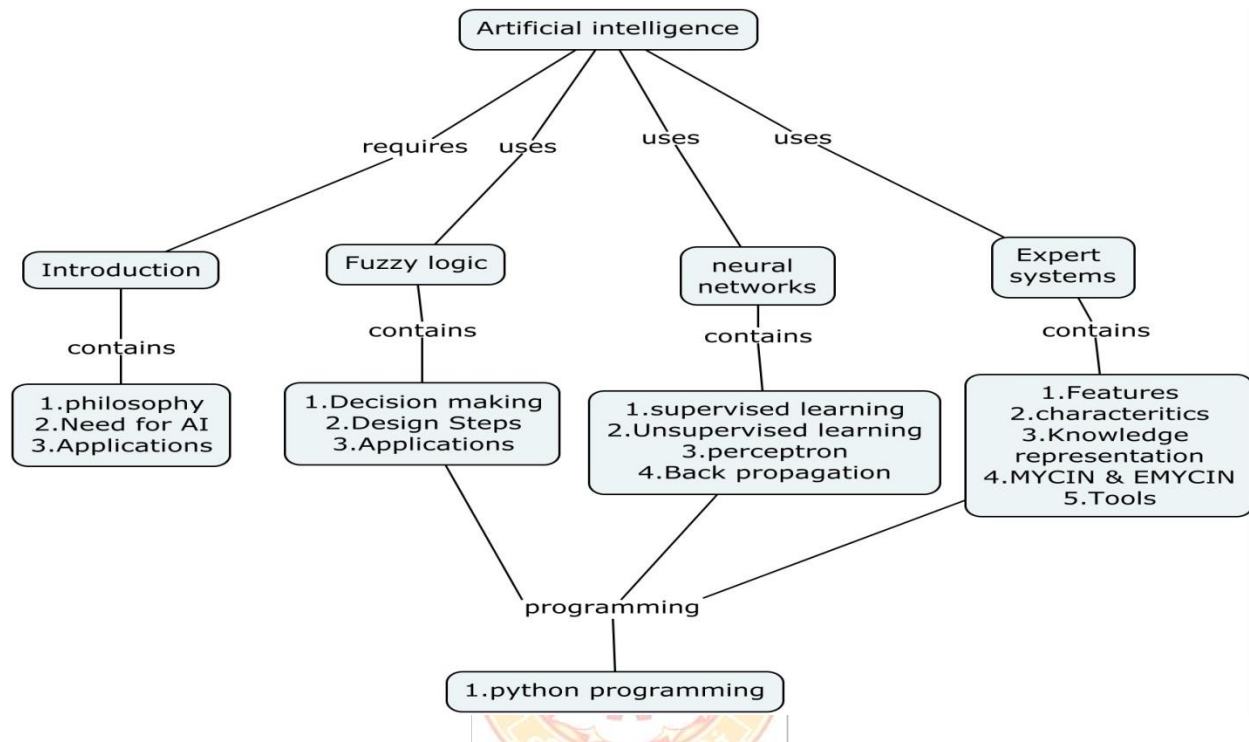

Syllabus

Artificial intelligence: Introduction, philosophy, need for AI, Applications

Fuzzy sets, logic operations and relations: Fuzzy Decision making, Design steps in Fuzzy logic Controller, Application of fuzzy logic controller.

Neural Networks: Basic Concepts and major classes of neural networks, supervised and unsupervised learning, single layer perceptron, multilayer perceptron, Back propagation

Expert Systems: Definition – Features of an expert system – Organization – Characteristics – Prospector – Knowledge Representation in expert systems – Expert system tools – MYCIN – EMYCIN.

Programming: use of python programming for fuzzy logic, implementation of neural networks, realisation of genetic algorithms.

Text Books

1. Stuart Russell and Peter Norvig, "Artificial Intelligence : A Modern Approach" , PEARSON , Third edition ,2015
2. Tom M. Mitchell "Machine Learning", McGraw-Hill Science/Engineering/Math,1997

Reference Books

1. The scikit-fuzzy Documentation Release 0.2
2. www.tensorflow.org
3. Mitchell Melanie. A Bradford Book "An Introduction to Genetic Algorithms", The MIT Press Cambridge, Massachusetts ,Fifth printing, 1999
4. Tariq Rashid, "Make Your Own Neural Network", 2016

Course Contents and Lecture Schedule

Sl.No.	Topic	No of Lectures
1	Artificial Intelligence	
1.1	Introduction	2
1.2	Philosophy	2
1.3	Need for AI	2
1.4	Applications	2
2	Fuzzysets, Logic operations and relations	
2.1	Fuzzy Decision Making	2
2.2	Design Steps in Fuzzy Logic Controller	2
2.3	Application of Fuzzy logic controller	2
3	Neural Networks	
3.1	Basic Concepts in neural networks	1
3.2	Major classes in neural Networks	1
3.3	Supervised learning	2
3.4	Unsupervised learning	2
3.5	Single layer Perceptron	1
3.6	Multilayer Perceptron	
3.7	Back Propagation	1
4	Genetic Algorithms	
4.1	Procedural steps	1
4.2	Selection	1
4.3	Crossover	2
4.4	Mutation	2
4.5	Application of Genetic Algorithm	1
5	Programming	
5.1	Basic Python programming	2
5.2	Scikit-Fuzzy toolbox for fuzzylogic	2
5.3	Tensorflow toolbox for neural networks	2
5.4	Python and deap toolbox for genetic algorithms	2
	Total	37

Course Designers:

- | | | |
|----|-----------------|-------------------------|
| 1. | Dr.G.kanagaraj | gkmec@tce.edu |
| 2. | S.Parthasarathi | Parthasarathi_s@tce.edu |

14MTPQ0**MODERN CONTROL SYSTEMS**

Category	L	T	P	Credit
PE	3	0	0	3

Preamble

The subject of modern control systems is an important area of automatic control. Learning basic techniques of modern control analysis and design can significantly enhance the ability of control engineer to deal with practical control problems efficiently. Modern technology, such as high speed high accuracy robots or high performance aircrafts, is demanding control systems with much more stringent design specifications. Modern control occupies an increasingly conspicuous position in control. Adaptive filters and controllers are well fitted for uncertain environments.

Prerequisite

- 14MT520-Control system

Course Outcomes

On the successful completion of the course, students will be able to

CO1	Model the given electrical, mechanical and electro mechanical systems in various standard forms of state space method	Understand
CO2	Identify the output response, controllability and observability of given electrical, mechanical and electro mechanical system.	Apply
CO3	Design the controller using pole placement and state feedback approach	Apply
CO4	Design adaptive filters and adaptive controllers	Apply
CO5	Obtain the estimation using design of observer and kalman filters	Apply

Mapping with Programme Outcomes

COs	PO1	PO2	PO3	PO4	PO5	PO6	PO7	PO8	PO9	PO10	PO11	PO12
CO1	S	S	M	M	M	-	-	-	-	L	-	M
CO2	S	S	L	S	M	-	-	-	-	M	-	M
CO3	S	S	L	S	M	-	-	-	-	S	-	M
CO4	S	S	S	S	M	-	-	-	-	M	-	M
CO5	S	S	M	S	S	-	-	-	-	S	-	M

S- Strong; M-Medium; L-Low

Assessment Pattern

Bloom's Category	Continuous Assessment Tests			Terminal Examination
	1	2	3	
Remember	20	20	20	20
Understand	20	20	20	20
Apply	60	60	60	60
Analyse	-	-	-	-
Evaluate	-	-	-	-
Create	-	-	-	-

Course Level Assessment Questions

Course Outcome 1 (CO1):

1. Define transition Matrix.
2. Define Canonical form.
3. Consider the following transfer function system:

$$\frac{Y(s)}{U(s)} = \frac{s + 6}{s^2 + 5s + 6}$$

Obtain the state space representation of this system in (a) controllable canonical form and (b) observable canonical form.

Course Outcome 2 (CO2):

1. Check the controllability and comment on your results.
2. $T(z) = \frac{z^2 + 5z + 6}{z^3 + 10z^2 + 29z + 20}$
3. Explain state controllability and output controllability.
4. Comment on controllability and observability of the signal flow graph.

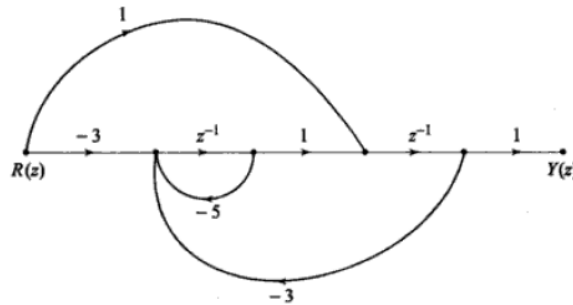

Course Outcome 3(CO3):

1. Plant transfer function is $G(s) = 1/(s+3)$. Derive the digital control algorithm so that damping ratio is 0.5 and natural frequency is 5 rad/sec.
2. The regulator system has the plant

$$\dot{x} = \begin{bmatrix} 0 & 1 \\ 20.6 & 0 \end{bmatrix} x + \begin{bmatrix} 0 \\ 1 \end{bmatrix} u$$

$$y = [1 \quad 0]x$$

Design a control law $u = -kx$ so that the closed loop system has eigenvalues at $\pm j 2.4$. -1.8

Course Outcome 4 (CO4):

1. Identify the output error direct adaptive control structure.
2. State the two differences between input and output error.
3. List the implementation procedure of indirect adaptive control algorithm.
4. State LMS, NLMS, RLS rules for adaptation.

Course Outcome 5 (CO5):

1. Define a full order observer.
2. Design reduced order observer that makes the estimation error to decay at least as fast as e^{-10t} . For the following system

$$\dot{x} = \begin{bmatrix} 1 & 0 \\ 0 & 0 \end{bmatrix} x + \begin{bmatrix} 1 \\ 1 \end{bmatrix} u$$

$$y = [2 \ 1]x$$

Derive the predictive kalman filter by state space method.

Concept Map

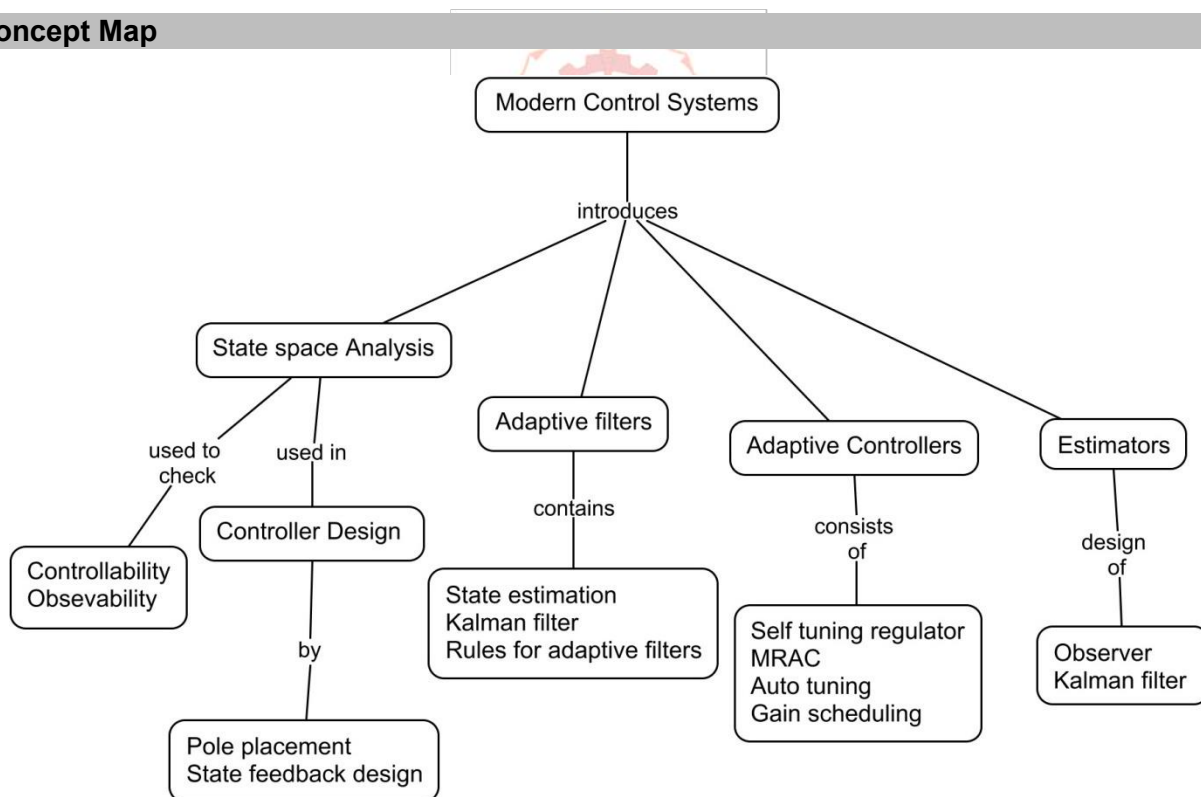

Syllabus

***Syllabus will be covered in discrete domain*

State space analysis: Introduction to state space, state space modeling, implementation using analog computers, state space to transfer function, canonical forms, solution of state equations, state controllability, output controllability, state observability, output observability.

Controller design using state space: Pole placement, State feedback controller.

Adaptive filters: State estimation, kalman filter LMS, NLMS, RLS rules for adaptation, adaptive filters.

Adaptive control: Introduction- deterministic self tuning regulator: indirect and direct self tuning regulator- model reference adaptive system: Design of MRAS using Lyapunov and MIT rule- auto tuning and gain scheduling adaptive control design with examples.

Estimation: Design of observer, design of kalman filter.

Text Book

1. M.Gopal, "**Digital control and State Variable Methods**", 2nd Edition, Tata McGraw-Hill, 2006, ISBN: 0070483027.
2. P. A. Ioannou and J. Sun, "**Robust Adaptive Control**", Prentice-Hall, 1995

Reference Books

1. M.Gopal, "**Digital Control Engineering**", New age International Publishers 2014.
2. Richard C.Dorf, Robert H.Bishop, "**Modern Control Systems**", 11th Edition, Pearson Education, Inc., 2008, ISBN:9780132067102.
3. Shankar Sastry, Marc Bodson, "**Adaptive Control**", Prentice-Hall, Inc. ISBN: 0130043265

Course Contents and Lecture Schedule

Module No.	Topic	No. of Lectures
1	State space analysis	
1.1	Introduction to State space	1
1.2	State space modelling, implementation using analog computers	1
1.3	State space to transfer function, Canonical forms	2
1.4	Solution of state equations	2
1.5	State controllability, output controllability	2
1.6	State observability, output observability	2
2	Controller design using state space	
2.1	Pole placement	2
2.2	Design of State feedback controller	2
3	Adaptive filters	
3.1	State estimation	2
3.2	Kalman filter	1

3.3	LMS, NLMS, RLS rules for adaptation		2
3.4	Adaptive filters		2
4	Adaptive control		
4.1	Introduction		1
4.2	Deterministic self tuning regulator		2
4.3	Indirect and direct self tuning regulator		2
4.4	Model reference adaptive system		2
4.5	Design of MRAS using Lyapunov and MIT rule		2
4.6	Auto tuning and gain scheduling adaptive control		2
4.7	Adaptive control design with examples		2
5	Estimation		
5.1	Design of observer		2
5.2	Design of kalman filter		2
TOTAL			38

Course Designers:

1. Ms. S. Sivapriya
2. Mr. A. Prakash

ssmect@tce.edu
apmech@tce.edu

14MTPR0

**MECHANICAL AND THERMAL
PACKAGING OF ELECTRONICS**

Category	L	T	P	Credit
PE	2	1	0	3

Preamble

All electronic components depend on current flow through resistance. Current flow through any resistance leads to heat dissipation according to joules law of heating. Removal of heat from electronic components is inevitable. If the heat is not removed properly, it leads to the improper functioning or even failure of the component Thermal management deals with the removal of heat from electronic components. Electronics plays a major role in almost all walks of our life. Hence understanding the thermal management of electronics is important.

Prerequisite

- 14MT340-Thermal Engineering and Fluid Mechanics

Course Outcomes

On the successful completion of the course, students will be able to

CO1	Calculate Thermal Resistance and surface temperature of electronic component using conductive cooling laws	Apply
CO2	Solve problems related to radiation heat transfer from electronic components	Apply
CO3	Estimate Convection heat transfer requirements for electronic equipment	Apply
CO4	Understand the significance of vibration shock and reliability	Understand

Mapping with Programme Outcomes

COs	PO1	PO2	PO3	PO4	PO5	PO6	PO7	PO8	PO9	PO10	PO11	PO12
CO1.	M	-	-	-	-	L	-	-	M	-	-	-
CO2.	S	-	-	M	-	-	-	L	-	-	-	L
CO3	-	M	-	L	-	-	-	-	-	L	L	-
CO4	-	S	L	-	L	-	L	-	L	L	-	M

S- Strong; M-Medium; L-Low

Assessment Pattern

Bloom's Category	Continuous Assessment Tests			Terminal Examination
	1	2	3	
Remember	20	20	20	20
Understand	40	40	40	40
Apply	40	40	40	40
Analyse	-	-	-	-
Evaluate	-	-	-	-
Create	-	-	-	-

Course Level Assessment Questions

Course Outcome 1 (CO1):

- Heat is to be conducted along a PCB with copper cladding on one side. The PCB is 12 cm long and 12 cm wide, and the thicknesses of the copper and epoxy layers are 0.06 mm and 0.5 mm, respectively. Disregarding heat transfer from the side surfaces, determine the percentages of heat conduction along the copper ($k = 386 \text{ W/m} \cdot ^\circ\text{C}$) and epoxy ($k = 0.26 \text{ W/m} \cdot ^\circ\text{C}$) layers. Also, determine the effective thermal conductivity of the PCB.
- The heat generated in the circuitry on the surface of a silicon chip ($k = 130 \text{ W/m} \cdot ^\circ\text{C}$) is conducted to the ceramic substrate to which it is attached. The chip is 6 mm \times 6 mm in size and 0.5-mm thick and dissipates 3W of power. Determine the temperature difference between the front and back surfaces of the chip in steady operation.
- Consider a 15-cm \times 18-cm glass-epoxy laminate ($k = 0.26 \text{ W/m} \cdot ^\circ\text{C}$) whose thickness is 1.4 mm. In order to reduce the thermal resistance across its thickness, cylindrical copper fillings ($k = 386 \text{ W/m} \cdot ^\circ\text{C}$) of diameter 1 mm are to be planted throughout the board with a center-to-center distance of 3 mm. Determine the new value of the thermal resistance of the epoxy board for heat conduction across its thickness as a result of this modification.
- Consider a thermal conduction module with 80 chips, each dissipating 4 W of power. The module is cooled by water at 18°C flowing through the cold plate on top of the module. The thermal resistances in the path of heat flow are R_{chip} is 12°C/W between the junction and the surface of the chip, R_{int} is 9°C/W between the surface of the chip and the outer surface of the thermal conduction module, and R_{ext} is 7°C/W between the outer surface of the module and the cooling water. Determine the junction temperature of the chip.

Course Outcome 2 (CO2):

- A cylindrical electronic component whose diameter is 2 cm and length is 4 cm is mounted on a board with its axis in the vertical direction and is dissipating 3 W of power. The emissivity of the surface of the component is 0.8, and the temperature of the ambient air is 30°C. Assuming the temperature of the surrounding surfaces to be 20°C, determine the average surface temperature of the component under combined natural convection and radiation cooling.
- Consider a power transistor that dissipates 0.1 W of power in an environment at 30°C. The transistor is 0.4 cm long and has a diameter of 0.4 cm. Assuming heat to be transferred uniformly from all surfaces, determine (a) the heat flux on the surface of the transistor, in W/cm², and (b) the surface temperature of the transistor for a combined convection and radiation heat transfer coefficient of 18 W/m² \cdot °C.
- The components of an electronic system dissipating 150 W are located in a 1-m-long horizontal duct whose cross section is 15 cm \times 15 cm. The components in the duct are cooled by forced air, which enters at 30°C at a rate of 0.4 m³/min and leaves at 45°C. The surfaces of the sheet metal duct are not painted, and thus radiation heat transfer from the outer surfaces is negligible. If the ambient air temperature is 25°C, determine

(a) the heat transfer from the outer surfaces of the duct to the ambient air by natural convection and (b) the average temperature of the duct.

Course Outcome 3 (CO3):

1. A desktop computer is to be cooled by a fan. The electronic components of the computer consume 75 W of power under full-load conditions. The computer is to operate in environments at temperatures up to 45°C and at elevations up to 3400 m where the atmospheric pressure is 66.63 kPa. The exit temperature of air is not to exceed 60°C to meet reliability requirements. Also, the average velocity of air is not to exceed 110 m/min at the exit of the computer case, where the fan is installed to keep the noise level down. Determine the flow rate of the fan that needs to be installed and the diameter of the casing of the fan.
2. An enclosure contains an array of circuit boards, 15 cm high and 20 cm long. The clearance between the tips of the components on the PCB and the back surface of the adjacent PCB is 0.3 cm. Each circuit board contains 75 square chips on one side, each dissipating 0.15 W of power. Air enters the space between the boards through the 0.3-cm \times 15-cm cross section at 40°C with a velocity of 300 m/min. Assuming the heat transfer from the back side of the circuit board to be negligible, determine the exit temperature of the air and the highest
3. surface temperature of the chips
4. A sealed electronic box is to be cooled by tap water flowing through channels on two of its sides. It is specified that the temperature rise of the water not exceed 3°C. The power dissipation of the box is 2 kW, which is removed entirely by water. If the box operates 24 h a day, 365 days a year, determine the mass flow rate of water flowing through the box and the amount of cooling water used per year.
5. An array of power transistors, each dissipating 2 W of power, is to be cooled by mounting them on a 20-cm \times 920-cm square aluminum plate and blowing air over the plate with a fan at 30°C with a velocity of 3 m/s. The average temperature of the plate is not to exceed 60°C. Assuming the heat transfer from the back side of the plate to be negligible, determine the number of transistors that can be placed on this plate.

Course Outcome 4 (CO4):

1. Discuss various types of motions.
2. Explain Free and induced vibration.
3. Write a note on electrical reliability.

Concept Map

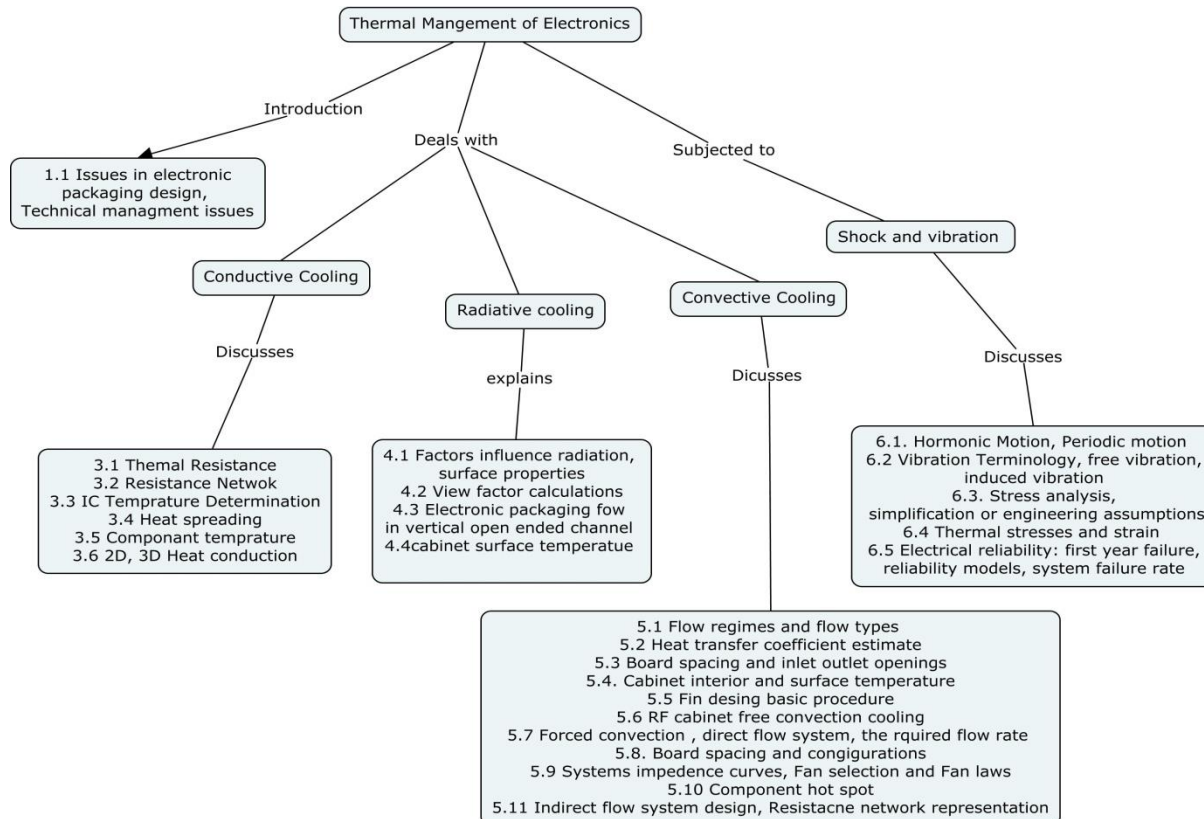

Syllabus

Introduction issues in electronics packaging design: Technical management issues electronics design packaging / enclosure design reliability

Basic heat transfer: conduction, convection, and radiation basic equations and concepts general equations. Non-dimensional groups: Nusselt number, Grashof number, Prandtl number, Reynolds number, problems.

Conductive cooling: Thermal resistance, problem and calculations. Resistance Network: Problems and Calculation, IC Temperature Determination, heat spreading, junction-to-case resistance, contact interface resistance, Modelling the Interface- Calculation of Component Temperature. Introduction to 2-d or 3-d heat conduction

Radiation cooling: factors influencing radiation, Surface Properties, View Factor Calculations, Electronics Packaging Problem, Flow in a Vertical Open-ended Channel, Cabinet surface temperature.

Fundamentals of convection cooling: Flow Regimes, Types and Influences free (or natural) convection, estimates of Heat Transfer Coefficient, Board Spacing and Inlet-Outlet Openings design Tips, Cabinet Interior and Surface Temperature. **Fin design:** Basic Procedure, RF Cabinet Free Convection cooling fin Design. **Forced convection direct flow system design:** The Required Flow Rate, Board Spacing and Configurations, System's Impedance Curve, Fan

Selection and Fan Laws, Component Hot Spot. **Indirect flow system design:** Resistance Network Representation.

Basics of shock and vibration: Harmonic Motion, Periodic Motion, Vibration Terminology, Free Vibration, Forced Vibration, Induced Stresses, Random Vibration

Design and analysis for mechanically reliable systems: Stress Analysis, Simplification or Engineering Assumptions, Failure Life Expectancy, Thermal Stresses and Strains

Electrical reliability: First-Year Failures, Reliability Models System Failure Rate

Text Book

1. Ali Jamnia, "**Practical Guide to Packaging of Electronics: Thermal and Mechanical Design and Analysis**", Marcel Dekker, 2003

Reference Books

1. Ralph Remsberg, "**Thermal Design of Electronic Equipment**", CRC Press, 2001
2. Dave S. Steinberg "**Cooling Techniques for Electronic Equipment**" John Wiley & Sons, 1991, Second Edition.
3. Allan D Kraus and Avram Bar-Cohen "**Thermal Analysis and Control of Electronic Equipment**" Hemisphere Publishing Corporation, 1983.
4. Yunus A Cengel, "**Heat Transfer a Practical Approach**", Tata Mcgraw Hill, 2002

Course Contents and Lecture Schedule

SI.No.	Topic	No. of Lectures
1	INTRODUCTION	
1.1	Issues in electronics packaging design technical management	1
1.2	Electronics Design	1
1.3	Packaging / Enclosure Design	1
1.4	Reliability	
2	BASIC HEAT TRANSFER	
2.1	Conduction	1
2.2	Convection	1
2.3	Radiation	1
2.4	Non dimensional groups: Nusselt Number, Grashof Number, Prandtl Number, Reynolds Number	
3	CONDUCTIVE COOLING	
3.1	Thermal resistance, problems	1
3.2	Resistance network, problems	1
3.3	IC Temperature Determination	1
3.4	Heat spreading, Junction-to-case resistance, Contact interface resistance. Modelling of the Interface	2
3.5	Calculation of the Component Temperature	2
3.6	2-d or 3-d heat conduction	1

Sl.No.	Topic	No. of Lectures
4	RADIATION COOLING	
4.1	Factors influencing radiation, Surface Properties	2
4.2	View Factor Calculations	1
4.3	Electronics Packaging Flow in a Vertical Open-ended Channel	1
4.4	Cabinet surface temperature	
5	FUNDAMENTALS OF CONVECTION COOLING	
5.1	Flow Regimes, Flow types and Influences, Free (or natural) convection	1
5.2	Estimates of Heat Transfer Coefficient	1
5.3	Board Spacing and Inlet-Outlet Openings	1
5.4	Cabinet Interior and Surface Temperature	1
5.5	Fin design, basic Procedure	1
5.6	RF Cabinet Free Convection Cooling	1
5.7	Forced convection, direct flow system design, The Required Flow Rate	1
5.8	Board Spacing and Configurations	1
5.9	System's Impedance Curve, Fan Selection and Fan Laws	1
5.10	Component Hot Spot	1
5.11	Indirect flow system design, Resistance Network Representation	1
6	BASICS OF SHOCK, VIBRATION AND RELIABILITY	
6.1	Harmonic Motion, Periodic Motion	
6.2	Vibration Terminology Free Vibration, Forced Vibration, Induced Stresses, Random Vibration	3
6.3	Stress Analysis, Simplification or Engineering Assumptions	3
6.4	Thermal Stresses and Strains	2
6.5	Electrical reliability, First-Year Failures, Reliability Models, System Failure Rate	2
	Total	40

Course Designers:

- | | | |
|---|-----------------------|-----------------|
| 1 | Dr. G.Kumaraguruparan | gkgmech@tce.edu |
| 2 | Mr. M.Manimegalan | mmech@tce.edu |

14MTPT0

DATA ANALYTICS

Category	L	T	P	Credit
PE	3	0	0	3

Preamble

The course on Data Analytics aims to emphasize the need for Data Engineering and covers various text and streaming data analytics techniques. The course facilitates the student to tackle data analysis problems that exist in real world by using the open source tools.

Prerequisite

- No prerequisites

Course Outcomes

On the successful completion of the course, students will be able to

Course Outcome	Blooms Level
CO1 Identify the big data environment for performing data quality analysis on large data sets.	Apply
CO2 Apply NoSQL data models for unstructured data	Apply
CO3 Perform predictive analytics for text and streaming data	Apply
CO4 Interpret machine learning methods and strategies for data analysis.	Apply

Mapping with Programme Outcomes

COs	PO1	PO2	PO3	PO4	PO5	PO6	PO7	PO8	PO9	PO10	PO11	PO12
CO1.	S	M			S		S					M
CO2.	S	M			S							M
CO3.	S	M			S			S	S	S		M
CO4.	S	M			S			S	S	S		M

S- Strong; M-Medium; L-Low

Assessment Pattern

Bloom's Category	Continuous Assessments			Terminal Examination
	Test 1	Test 2	Test 3	
Remember	40	30	0	30
Understand	30	40	30	30
Apply	30	30	70	40
Analyse	0	0	0	0
Evaluate	0	0	0	0
Create	0	0	0	0

Course Level Assessment Questions**Course Outcome 1 (CO1):**

- Define data Analytics.
- Mention some of the data analytics applications.

3. Describe the Analytics process model.
4. Compute the technique of sampling and pre-processing for the data set of a bank application. Identify the fields and labels over the dataset and perform all the steps over pre-processing technique.

Course Outcome 2 (CO2):

1. Perform data analytics on medical big data using Hadoop and infer the output with respect to processing time and space complexity.
2. Apply multiclass classification techniques for the application that you prefer and provide the necessary specifications that you observe and clearly distinguish over binary classification method for the application that you have chosen.
3. Write different steps involved in text summarization.
4. Explain how social media data is being used for web analysis.

Course Outcome 3 (CO3):

1. Prepare a predictive model for resource utilization by a computer system which has maximum size of RAM 512 MB, and 120 GB hard disk, which runs 6 processes at a given time with the time allotted for each of the process is about 2 milliseconds.
2. Point out the need for using a multiclass classification model in a system. Clearly provide the reasons over binary classification system with necessary illustrations.
3. Depict a predictive model using multiclass classification techniques for any real-time application.

Course Outcome 4 (CO4):

1. Illustrate the need for multiclass classification and how it is different from binary classification technique.
2. Explain text analytics methods with illustrative examples.
3. Explain Naïve Bayesian model to classify text documents.
4. Apply suitable streaming analytics techniques to analyze video data.

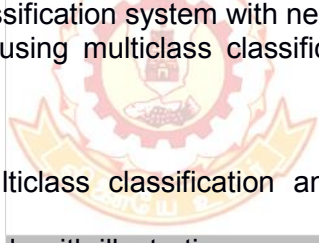

Concept Map

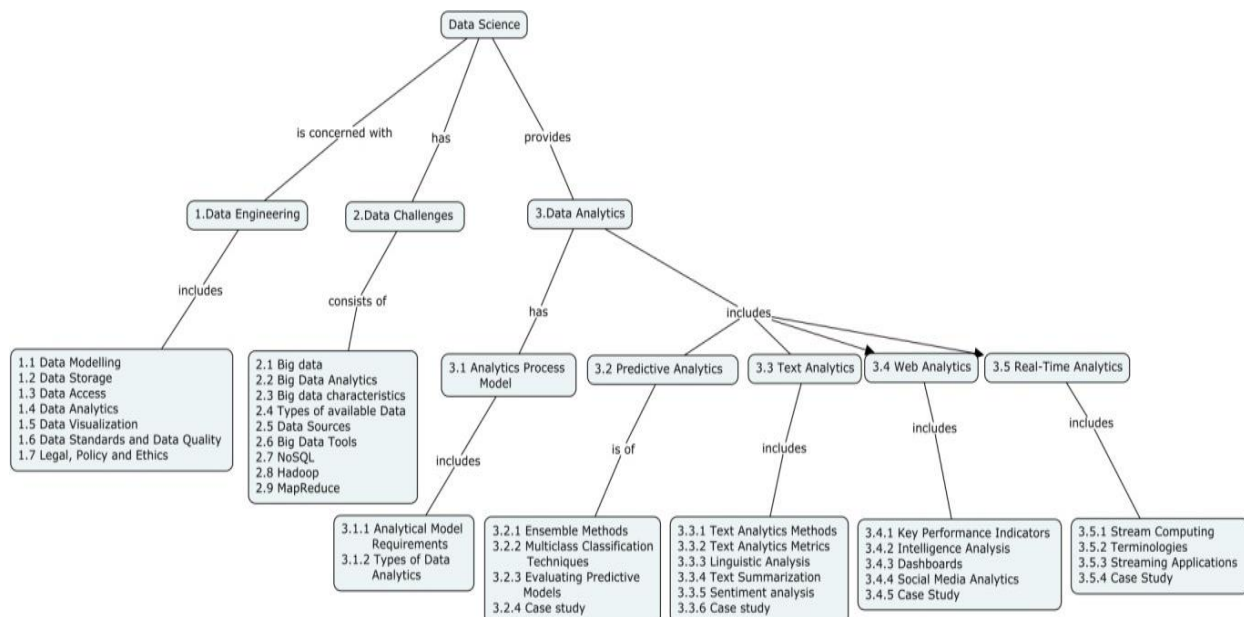

Syllabus

Data Engineering: Data Modelling – Data Storage – Data Access - Data Analytics – Data Visualization – Data Standards and Data Quality - Legal, Policy and Ethics.

Data Challenges: Big data – Big Data Analytics vs Business Intelligence - Big data characteristics – Types of available Data – Data Sources – Big Data Tools –Programming in R and python -Use cases.

Data Analytics – Analytics Process Model – Analytical Model Requirements - Types of Data Analytics.

Predictive Analytics – Ensemble Methods – Multiclass Classification Techniques – Evaluating Predictive Models – Case study for any health care system.

Text Analytics – Text Analytics Methods – Text Analytics Metrics – Linguistic Analysis - Text Summarization - Sentiment analysis – Case study for text data generation system.

Web Analytics – Key Performance Indicators – Intelligence Analysis – Dashboards - Social Media Analytics – Case Study for social media data analytics.

Real Time Analytics – Stream Computing – Terminologies – Streaming Applications – Case Study for video data analytics.

Text Book

1. Bart Baesens, “Analytics in a Big Data World”, The Essential Guide to Data Science and its Applications, Wiley, First edition, 2014.
2. Thomas H. Davenport, Jeanne G. Harris, “Competing on Analytics: The New Science of Winning”, Harvard Business Review Press, First edition, 2007.

Reference Books

1. Paul C. Zikopoulos, Chris Eaton, “Understanding Big Data”, McGraw-Hill, 2012 (eBook from IBM).

Web References

1. <http://cloudera.com/content/cloudera/en/training/courses/administrator-training.html>
2. <http://bigdatauniversity.com/>

Course Contents and Lecture Schedule

S.No	Topic	No. of Lectures
1	Data Engineering	
1.1	Data Modelling	2
1.2	Data Storage	
1.3	Data Access	2
1.4	Data Analytics	
1.5	Data Visualization	1
1.6	Data Standards and Data Quality	2
1.7	Legal, Policy and Ethics	
2	Data Challenges	

S.No	Topic	No. of Lectures
2.1	Big data	2
2.2	Big Data Analytics vs Business Intelligence	
2.3	Big data characteristics	
2.4	Types of available Data	1
2.5	Data Sources	
2.6	Big Data Tools	1
2.7	Programming in R	3
2.8	Programming in Python	3
2.9	Use cases	1
3	Data Analytics	
3.1	Analytics Process Model	
3.1.1	Analytical Model Requirements	2
3.1.2	Types of Data Analytics	
3.2	Predictive Analytics	
3.2.1	Ensemble Methods	1
3.2.2	Multiclass Classification Techniques	1
3.2.3	Evaluating Predictive Models	1
3.2.4	Case study	2
3.3	Text Analytics	
3.3.1	Text Analytics Methods	2
3.3.2	Text Analytics Metrics	
3.3.3	Linguistic Analysis	1
3.3.4	Text Summarization	2
3.3.5	Sentiment analysis	
3.3.6	Case study	2
3.4	Web Analytics	
3.4.1	Key Performance Indicators	1
3.4.2	Intelligence Analysis	
3.4.3	Dashboards	2
3.4.4	Social Media Analytics	
3.4.5	Case Study	2
3.5	Real Time Analytics	
3.5.1	Stream Computing	2
3.5.2	Terminologies	
3.5.3	Streaming Applications	2
3.5.4	Case Study	
Total lectures		41

Course Designers:

1. Mr.S.Parthasarathi parthasarathi_s@tce.edu
2. Mr.S.A.R.Sheik masthan sarsmech@tce.edu

14MTPU0

MOBILE ROBOTICS

Category	L	T	P	Credit
PE	3	0	0	3

Preamble

Mobile Robotics is a fast evolving, solutions orientated, industry within which the robotics engineer is a significant and growing work role. Mobile robotics is an important part of the industry, with applications in diverse industries, including manufacturing, agriculture, aerospace, mining, and medicine. In this course, the students would learn the types of mobile robots, its kinematics and important functionalities.

Prerequisite

Nil

Course Outcomes

On successful completion of the course, students will be able to

CO1	Derive the kinematics of various mobile robots	Understand
CO2	Explain the selection and significance of sensor implementation in mobile robots	Understand
CO3	Develop the control architecture for the mobile robot.	Apply
CO4	Implement path planning algorithms according to the environment	Apply

Mapping with Programme Outcomes

COs	PO1	PO2	PO3	PO4	PO5	PO6	PO7	PO8	PO9	PO10	PO11	PO12
CO1	S	M	L	L	-	-	L	-	-	M	S	L
CO2	S	S	L	L	-	-	-	-	-	M	S	L
CO3	S	L	S	M	M	-	-	-	-	S	S	M
CO4	S	L	S	M	S	-	M	-	-	S	S	S

S- Strong; M-Medium; L-Low

Assessment Pattern

Bloom's Category	Continuous			Terminal Examination
	1	2	3	
Remember	20	20	20	20
Understand	50	50	50	50
Apply	30	30	30	30
Analyse	-	-	-	-
Evaluate	-	-	-	-
Create	-	-	-	-

Course Level Assessment Questions**Course Outcome 1 (CO1):**

1. List the types of kinematics in a mobile robot
2. Describe the basic constraints to be considered while developing a kinematic model.
3. Derive the kinematic model of a two wheeled robot shown below.

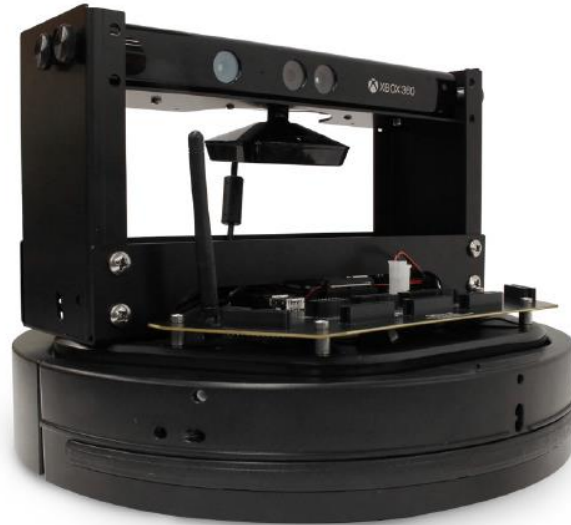
**Course Outcome 2(CO2):**

1. Describe the factors considered while selecting a sensor from a range of sensors.
2. List the common issues occurred while interfacing the sensor with the robotic circuitry.
3. Explain the sensor selection procedure and place in the chassis of the robot for the application considered.

Course Outcome 3 (CO3):

1. Develop the control architecture of a mobile robot which moves along a room and paints the wall at a height of 3m from the ground. Consider all the mechanical alternatives and draw all possible designs. Choose sensor, actuator, communication and interface method for all designs. The robot of mass 3 kg should reach the maximum velocity in 1 s, so an acceleration of 0.15m/s^2 is desired. The wheel radius is assumed to be 3 cm. Calculate the maximum torque and required power. According to the design considered, a differential (gear reduction mechanism) of gear ratio 12.5:1 is used to raise the spray gun to a particular height. Design optimum motor driving circuitry, signal conditioning circuit and algorithm for smooth functioning of the robot.



2. A military robot is used to sense the enemy and fire to kill. It uses a RGB camera, Kinect sensor, Infrared, thermal sensor and a pistol. Four wheel drive with servo motors is used to drive all the wheels. Raspery pi is used as the controller. Android application is developed to control the robot at the user end wirelessly with WIFI. Develop the control architecture for the robot.

Course Outcome 4 (CO4):

1. Consider an unknown environment in which the robot uses a camera for path planning. Select the path planning method so that the robot reaches the destination in less time. Note that the map of the environment is fed to the robot for reference. Explain how it learns the environment at first and develop an architecture of control.
2. Implement the path planning robot with A* algorithm and explain the algorithm to code.
3. Illustrate a weight lifting application with a set of robots of 30x40 cm, Select the sensors, its place in the robot for efficient working, actuators, mapping method and control mechanism. Control the formation of all the robots with each one programmed with different algorithms. Will it perform well? Explain the issues and solutions.

Concept Map

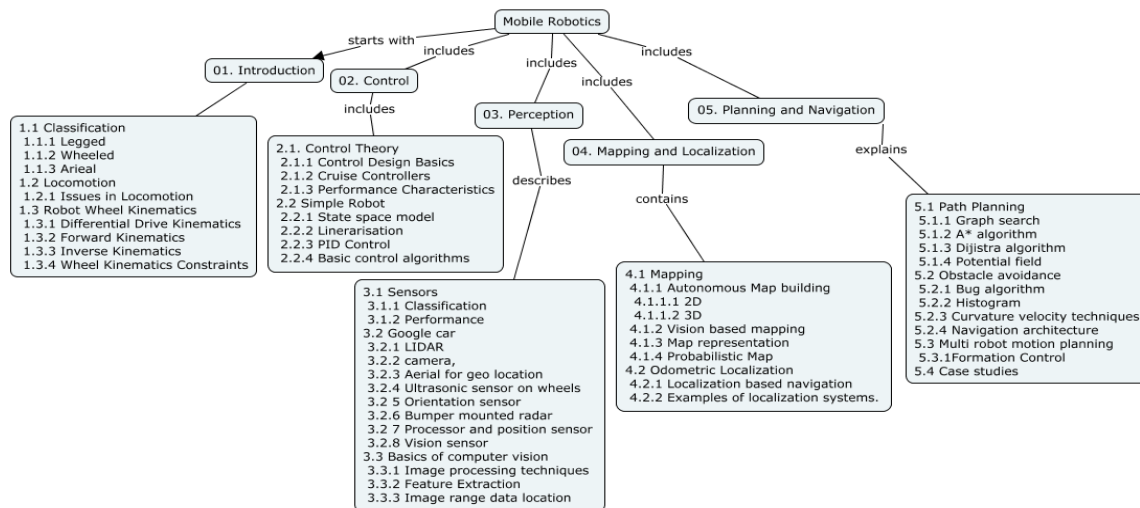

Syllabus

Introduction to Mobile Robots

Introduction to Mobile robots - Locomotion, Classification - Legged, Wheeled, Aerial - Key issues in locomotion. Mobile Robot Wheel Kinematics – Wheel Kinematic model- Differential drive Kinematics - Forward Wheel Kinematic model, Inverse Wheel Kinematic Model, Representing position, Wheel kinematic constraints. Motion control.

Control of Mobile Robots

Control theory - Control design basics, Cruise-Controllers, Performance Objectives of Simple robot – State space model, Linearization, LTI system, stability - PID control, basic control algorithms.

Perception

Selection of sensors for mobile robots – Classification, performance, **Google car** – LIDAR, camera, aerial for geo location, ultrasonic sensor on wheels, orientation sensor, bumper mounted radar, processor and position sensor. Vision sensor- Basics of computer vision, image processing techniques, feature extraction – image range data location recognition.

Mapping and Localization

Digital Maps, Autonomous map building -2D, 3D, Major challenges, Vision based mapping, Map representation, Probabilistic Map based localization- Odometric Localization, Kalman filter Localization- Case study about localization systems.

Planning and Navigation

Path and Motion Planning- Path Planning – graph search, A* algorithm, Dijkstra algorithm, Potential field. Obstacle avoidance – bug algorithm, histogram, curvature velocity techniques. Navigation architecture, Multi robot motion planning- Formation Control, Case studies

Text Books

1. Ronald Siegwart, Illah R. Nourbakhsh, Davide Scaramuzza, "Introduction to Autonomous Mobile Robots", MIT Press Publication, 2nd edition, 2011.
2. Janusz Będkowski "Mobile Robots - Control Architectures, Bio-Interfacing, Navigation, Multi Robot Motion Planning and Operator Training", InTech Publication, 2011.
3. W. Bolton, "Mechatronics – Electronic control systems in Mechanical & Electrical Engineering", Pearson Education Ltd., 2003.

Reference Books

1. A. Smaili and F. Mrad, "Applied Mechatronics", OXFORD university press published in April 2007.
2. Andon Venelinov Topalov, "Recent Advances in Mobile Robotics", published by InTech, Chapters published December 14, 2011

Course Contents and Lecture Schedule

Module No.	Topic	No. of Lectures
1	Introduction to Mobile Robots	
1.1	Introduction to Mobile robots	1
1.2	Locomotion, Classification - Legged, Wheeled, Aerial.	1

Module No.	Topic	No. of Lectures
1.3	Key issues in locomotion	1
1.4	Mobile Robot wheel Kinematics – Wheel Kinematic model	1
1.5	Differential drive Wheel kinematic model	1
1.6	Forward Wheel Kinematic model	1
1.7	Inverse Wheel Kinematic model	1
1.8	Representing position, Wheel kinematic constraints. Motion control	2
2	Control of Mobile Robots	
2.1	Control theory - Control design basics	1
2.2	Cruise-Controllers, Performance Objectives	1
2.3	Simple robot – State space model, Linearization	1
2.4	LTI system, stability	1
2.5	PID control	1
2.6	Basic control algorithms	1
3	Perception	
3.1	Selection of sensors for mobile robots – Classification, performance	1
3.2	Google car – LIDAR, camera,	1
3.3	Aerial for geo location,.	1
3.4	Ultrasonic sensor on wheels,	1
3.5	Orientation sensor, bumper mounted radar, processor and position sensor	1
3.6	Vision sensor	1
3.7	Basics of computer vision	1
3.8	Image processing techniques,	1
3.9	Feature extraction – image, range data location recognition.	1
4	Mapping and Localization	
4.1	Autonomous map building -2D, 3D	1
4.2	Major challenges	1
4.3	Vision based mapping, Map representation	1
4.4	Probabilistic Map	1
4.5	Odometric Localization, Localization based navigation	1
4.6	Case study about localization systems	1

Module No.	Topic	No. of Lectures
5	Planning and Navigation	
5.1	Path Planning – Graph search, A* algorithm	1
5.2	Dijkstra algorithm	1
5.3	Potential field	1
5.4	Obstacle avoidance – bug algorithm	1
5.5	histogram, curvature velocity techniques	1
5.6	Navigation architecture, Multi robot motion planning-	1
5.7	Formation Control	1
5.8	Case studies	1
Total Hours		38

Course Designers:

1. Mr S Julius Fusic
2. Mr M.A Ganesh

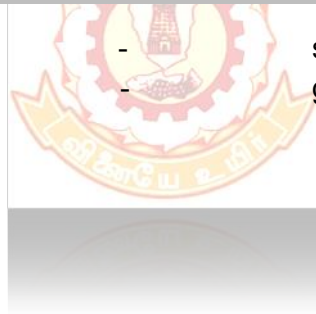

sjf@tce.edu
ganeshma2015@tce.edu

14MTPW0 VIRTUAL INSTRUMENTATION

Preamble

A virtual instrumentation system consists of an industry-standard computer or workstation equipped with powerful application software, cost-effective hardware such as plug-in boards, and driver software, which together perform the functions of traditional instruments. Virtual instruments represent a fundamental shift from traditional hardware-centered instrumentation systems to software-centered systems that exploit the computing power, productivity, display, and connectivity capabilities of popular desktop computers and workstations.

Advanced Modular Instrument hardware use the latest I/O and data processing technologies, including Analog to Digital Converters (ADC), Digital to Analog Converters, Field Programmable Gate Arrays (FPGAs), and PC busses to provide high resolution and throughput for measurements from 7 1/2 digit DC to 2.7 GHz. In combination with powerful software, engineers can create custom-defined measurements and sophisticated analysis routines.

Virtual instrumentation has been widely adopted in test and measurement areas and is rapidly making headway in control and design areas.

Prerequisite

Course Code: Nil

Course Outcomes

On the successful completion of the course, students will be able to

CO1	Define the terminologies and concepts used in virtual instrumentation	Remember
CO2	Will write graphical programs effectively.	Apply
CO3	Discuss in detail about ADC,DAC and Plug in boards used in Virtual Instrument	Understand
CO4	Choose appropriate Architecture/Template for realizing a given application	Apply
CO5	Develop virtual instrument programs for realizing Mechatronic Application	Apply

Mapping with Programme Outcomes

COS	PO1	PO2	PO3	PO4	PO5	PO6	PO7	PO8	PO9	PO10	PO11
CO1	S	L	L	L	S						L
CO2	S	S	S	S	S						M
CO3	S	L	L	L	M						L
CO4	S	M	S	M	S						L
CO5	S	S	S	S	S						M

S- Strong; M-Medium; L-Low

Assessment Pattern

Bloom's Category	Continuous Assessment Tests			Terminal Examination
	1	2	3	
Remember	20	20	20	20
Understand	20	60	20	20
Apply	60	20	60	60
Analyse	-	-	-	-
Evaluate	-	-	-	-
Create	-	-	-	-

Course Level Assessment Questions**Course Outcome 1 (CO1):**

1. Define Virtual Instrument.
2. Define Data Flow Programming.
3. List the advantages of Virtual Instrument over Traditional Instrument.
4. Define Cluster.
5. Write the functions of a Formula node.
6. Write the function of a shift register in a loop.

Course Outcome 2 (CO2):

1. Differentiate Virtual Instrument and Traditional Instrument.
2. Find the output of the given question.

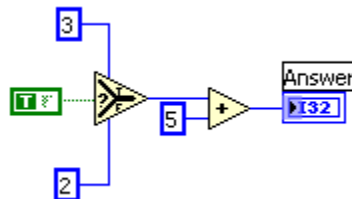

3. Describe the programming Architectures in a Virtual Instrument.
4. Build a VI that displays two random plots on a single chart. These should be Random numbers ($0 < x < 10$) and their five point moving average. The points should appear on your plots as points, while trend line should be a solid line.
5. Build a VI program to calculate the sum of 'n' Numbers.
6. Build a VI program to find the factorial of 'n' number.
7. Build a four function calculator using Case Structure. Use a Menu ring to select the function required.

Course Outcome 3 (CO3):

1. Explain about functioning of Flash type Analog to Digital Converter.
2. Discuss about weighted resistor Digital to Analog Converter.
3. Explain about successive approximation type Analog to Digital Converter.
4. A weighted Resistor digital to analog converter has $n=8$ bits, the reference voltage $V_R=10V$, the most significant bit resistance $R=12$ Kilo ohm, and the feedback resistance of the operational amplifier $R_f=6$ kilo ohm.

Calculate

- (a) The output voltage V_o corresponding to the least significant bit.
- (b) The output voltage V_o corresponding to the least significant bit.
- (c) The resolution.
- (d) The output voltage V_o corresponding to the binary input 10101100.
- (e) The maximum value of the output voltage.
- (f) The nominal full scale output voltage.

Course Outcome 4 (CO4):

1. State the reason for using state machine architecture for a given application.

Course Outcome 5 (CO5):

1. Develop a Virtual Instrument to realise a function generator to generate Saw tooth waveform with frequency 50Hz. Choose appropriate update rate for realising the above.
2. Develop a Virtual Instrument to acquire Temperature using J type Thermocouple for every one minute and store the data using Excel.
3. Develop a Virtual Instrument to acquire data about level of a tank using internet from a remote place and continuously display it for monitoring purpose.
4. Explain about building a machine vision based inspection system for inspection of fasteners.

Concept Map

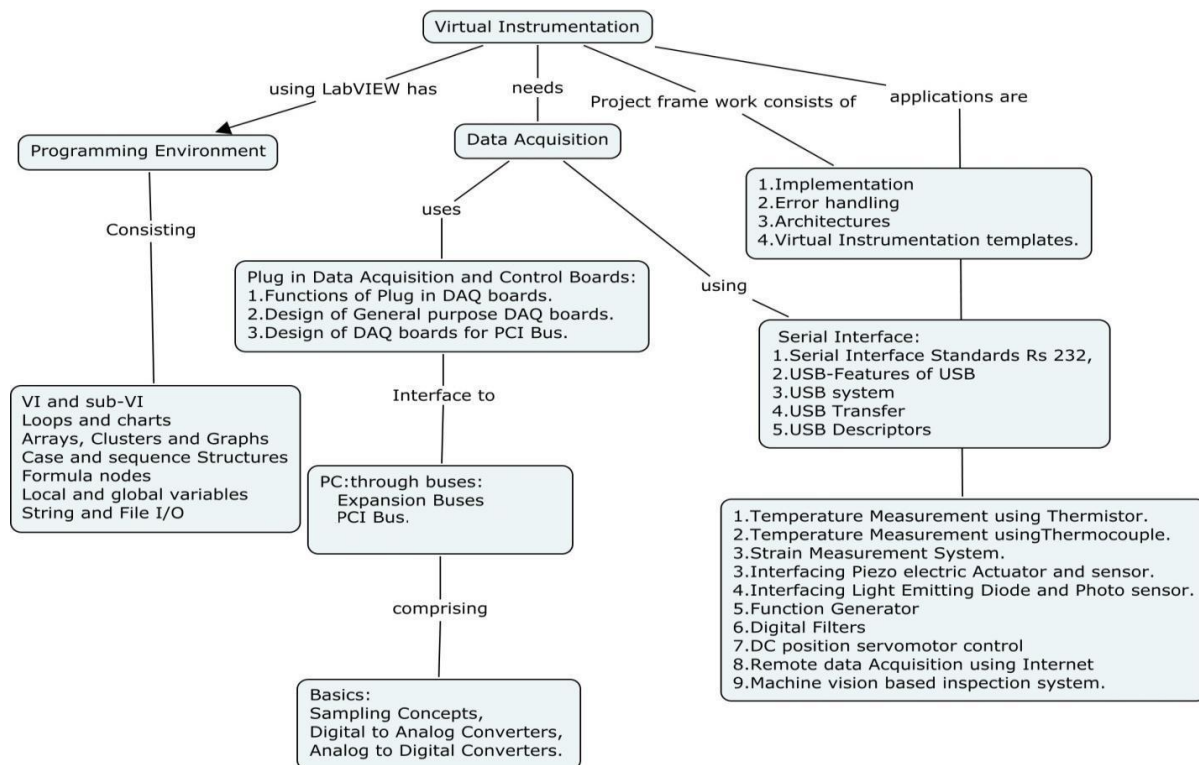

Syllabus

Introduction: Tradition Instrument, Virtual Instrument, Components of a VI, Difference between TI and VI, Advantages of VI. **VI Programming Environment:** Front panel, Block diagram, VI and sub-VI, loops and charts, arrays, clusters and graphs, case and sequence Structures, formula nodes, local and global variables, string and file I/O. **Data Acquisition:** Principles of Data Acquisition: Sampling Concepts, Digital to Analog Converters, Analog to Digital Converters. Interfacing To PC: Expansion Buses-ISA Bus, EISA Bus, PCI Bus. Plug in Data Acquisition and Control Boards: Functions of Plug in DAQ boards, Design of DAQ boards for PCI Bus. PXI. Instrument Control: GPIB. Data Acquisition using Serial Interface: Serial Interface Standards Rs 232, USB-Features of USB, USB system, USB Transfer, USB Descriptors. **Planning VI Applications:** Implementation, Error handling, architectures, Virtual Instrumentation templates. **Applications:** Temperature Measurement using Thermistor, Thermocouple, Strain Measurement System, Interfacing Piezo electric Actuator and sensor, Interfacing Light Emitting Diode and Photo sensor, Acceleration Measurement, Function Generator, Digital Filters, DC position servomotor control, Remote data Acquisition using Internet, Machine vision based inspection system. IC engine data acquisition system.

Text Book

1. Sanjay Gupta, Joseph John "**Virtual Instrumentation Using LabVIEW**", Tata McGraw Hill Education Private Limited, 2010.

Reference Books

1. N.Mathivanan, "**PC based Instrumentation: Concepts and Practice**" PHI Learning Pvt Ltd, 2007.
2. Jovitha Jerome, "**Virtual Instrumentation Using LabVIEW**", PHI Learning Pvt. Ltd-New Delhi, 2010.
3. Dan Neculescu "**Mechatronics**" Pearson Education, 2002.
4. "**LabVIEW User Manual**"-National Instruments, 2015.

Course Contents and Lecture Schedule

Module No.	Topic	No. of Lectures
1.0	Introduction:	
1.1	Tradition Instrument, Virtual Instrument, Components of a VI.	1
1.2	Difference between TI and VI, Advantages of VI.	
2.0	The VI Programming Environment	
2.1	Front panel, Block diagram, VI and sub-VI	1
2.2	Loops	1
2.3	Arrays and Clusters	1
2.4	Graphs and Charts	1
2.5	Case and Sequence Structures, Formula nodes	1
2.6	Local and Global variables	1
2.7	String and File I/O	2
3.0	Data Acquisition	
3.1	Principles of Data Acquisition: Sampling Concepts, Digital to Analog Converters, Analog to Digital Converters.	2
3.2	Interfacing To PC: Expansion Buses- ISA Bus, EISA Bus, PCI Bus.	2
3.3	Plug in Data Acquisition and Control Boards: Functions of Plug in DAQ boards.	1
3.4	Design of DAQ boards for PCI Bus.	1

Module No.	Topic	No. of Lectures
3.5	PXI Bus System	2
3.6	Instrument Control: GPIB	2
3.7	Data Acquisition using Serial Interface: Serial Interface Standards Rs 232,	2
3.8	USB-Features of USB, USB System, USB Transfer, USB Descriptors.	2
4.0	Planning VI applications	
4.1	Implementation, Error handling,	2
4.2	Architectures, Virtual Instrumentation templates.	2
5.0	Applications	
5.1	Temperature Measurement using Thermistor	1
5.2	Temperature Measurement using Thermocouple	
5.3	Strain Measurement System	1
5.4	Interfacing Piezo electric Actuator and sensor	1
5.5	Interfacing Light Emitting Diode and Photo sensor	1
5.6	Acceleration Measurement	1
5.7	Function Generator	1
5.8	Digital Filters	
5.9	DC position servomotor control	1
5.10	Remote Data Acquisition using Internet	1
5.11	Machine vision based inspection system.	1
	Total	36

Course Designers:

- | | | |
|----|-----------------|----------------------|
| 1. | Mr. Vivek T | tvivek@tce.edu |
| 2. | Ms.S.Siva Priya | Siva2692@hotmail.com |

14MTPY0 DESIGN OF MACHINE ELEMENTS

PE 3 0 0 3

Preamble

Design of machine elements is the process of deriving a system, component or process to meet desired needs. It is a decision making process, in which the basic sciences, mathematics and engineering sciences are applied to convert resources optimally to meet a stated objective. Among the fundamental elements of the design process are the establishment of objectives and criterion, synthesis, analysis, construction, testing and evaluation. Machine Elements Design deals with the creation of machine element that goes into the making of a machine as a product.

Prerequisites

- 14MT210- Engineering Mathematics
- 14MT320-Kinematics and Dynamics of Machinery

Course Outcomes

On the successful completion of the course, students will be able to

CO1.	Explain the design concepts of static and fatigue strength of mechanical components.	Understand
CO2.	Design the shafts, rigid and flexible couplings parametrically for different loading conditions.	Apply
CO3.	Design a suitable flat belt, V-belt ,chain drive and spur gear for specified loading condition	Apply
CO4.	Design a rolling contact bearing and sliding contact bearing for given power transmission application.	Apply
CO5.	Determine the efficiency of a power screw and the amount of load to be raised & lowered.	Apply

Mapping with Programme outcomes

COs	PO1	PO2	PO3	PO4	PO5	PO6	PO7	PO8	PO9	PO10	PO11	PO12
CO1.	M	M	L	L	-	S	S	-	S	-	-	S
CO2.	S	S	S	M	-	S	S	-	S	-	-	S
CO3.	S	S	M	M	-	S	S	-	S	-	-	S
CO4.	S	S	M	M	-	S	S	-	S	-	-	S
CO5.	S	S	M	M	-	S	S	-	S	-	-	S

S-Strong; M-Medium; L-Low

Assessment Pattern

Bloom's Category	Continuous Assessment Tests			Terminal Examination
	1	2	3	
Remember	20	20	20	20
Understand	30	30	30	30
Apply	50	50	50	50

Marks allocation

Sl. No.	Description	Marks
1	Terminal Theory Examination	50
2	Continuous assessment marks	30
3	Assignment	20
Total Marks		100

Course Level Assessment Questions

Course Outcome 1(CO1):

1. An overhang crank with pin and shaft is shown in figure. A tangential load of 15 kN acts on the crank pin. Determine the maximum principal stress and the maximum shear stress at the centre of the crankshaft bearing.

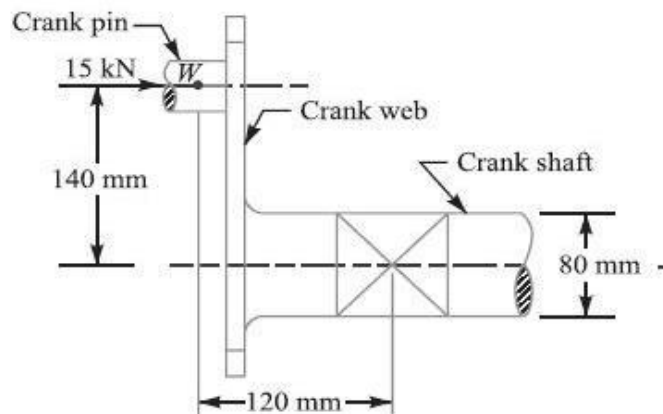

2. The load on a bolt consists of an axial pull of 10 kN together with a transverse shear force of 5 kN. Find the diameter of bolt required according to

1. Maximum principal stress theory.
2. Maximum shear stress theory.
3. Maximum principal strain theory.
4. Maximum strain energy theory.
5. Maximum distortion energy theory.

3. Determine the diameter of a circular rod made of ductile material with a fatigue strength (complete stress reversal), $\sigma_{-1} = 265$ MPa and a tensile yield strength of 350 MPa. The member is subjected to a varying axial load from $W_{\min} = 300 \times 10^3$ N to $W_{\max} = 700 \times 10^3$ N and has a stress concentration factor = 1.8. Use factor of safety as 2.0.

Course Outcome 2 (CO2):

1. A solid circular shaft is subjected to a bending moment of 3000 N-m and a torque of 10 000 N-m. The shaft is made of 45C8 steel having ultimate tensile stress of 700 MPa and a ultimate shear stress of 500 MPa. Assuming a factor of safety as 6, determine the diameter of the shaft.
2. Design the rectangular key for a shaft of 50mm diameter. The shearing and crushing stresses for the key material are 42MPa and 70MPa.
3. Design a bushed-pin type flexible coupling for connecting a motor shaft to a pump shaft for the following service conditions: Power to be transmitted = 40 kW ; speed of the motor shaft = 1000 r.p.m.; diameter of the motor shaft = 50 mm ; diameter of the pump shaft = 45 mm. The bearing pressure in the rubber bush and allowable stress in the pins are to be limited to 0.45 N/mm² and 25 MPa respectively.

Course Outcome 3 (CO3):

1. Design a fabric belt to transmit 15kW at 480rpm, from an engine to a line shaft at 1200rpm. The diameter of engine pulley is 600mm and centre distance between the pulley is 2m.
2. Design a V-belt drive and calculate the actual belt tension and average stress for the following data. Driven pulley diameter, D= 500 mm, driver pulley diameter, d=150 mm, center distance c=925 mm, speed n1 = 1000 rpm, n2 = 300 rpm and power, P = 7.5 kW.
3. Designs a chain drive to actuate a compressor from a 12 kW electric motor at 900 rpm, the compressor begin 250 rpm. Minimum centre distance should be 500 mm; the chain tension may be adjusted by shifting the motor on rails. The compressor is to work 8 hour/day.
4. A motor shaft rotating at 1500 rpm has to transmit 15kW to a low speed shaft with a speed reduction of 3:1. Assume starting torque to be 25% higher than the running torque. The teeth are 20° involutes with 25 teeth on the pinion. Both the pinion and gear are made of C45 steel. Design a spur gear drive to suit the above conditions and check for compressive and bending stresses and plastic deformations. Also sketch the spur gear drive.

Course Outcome 4 (CO4):

1. Design a journal bearing for a centrifugal pump from the following data: Load on the journal = 20 000 N; Speed of the journal = 900 r.p.m. Type of oil is SAE 10, for which the absolute viscosity at 55°C = 0.017 kg / m-s; Ambient temperature of oil = 15.5°C; Maximum bearing pressure for the pump = 1.5 N / mm². Calculate also mass of the lubricating oil required for artificial cooling, if rise of temperature of oil be limited to 10°C. Heat dissipation coefficient = 1232 W/m²/°C.
2. A full journal bearing of 50 mm diameter and 100 mm long has a bearing pressure of 1.4 N/mm². The speed of the journal is 900 r.p.m. and the ratio of journal diameter to the diametral clearance is 1000. The bearing is lubricated with oil whose absolute viscosity at the operating temperature of 75°C may be taken as 0.011 kg/m-s. The room temperature is 35°C. Find 1. The amount of artificial cooling required, and 2. The mass of the lubricating oil required, if the difference between the outlet and inlet temperature of the oil is 10°C. Take specific heat of the oil as 1850 J / kg / °C.

3. Select a single row deep groove ball bearing for a radial load of 4000 N and an axial load of 5000 N, operating at a speed of 1600 r.p.m. for an average life of 5 years at 10 hours per day. Assume uniform and steady load.

Course Outcome 5 (CO5):

1. A double threaded power screw, with ISO metric trapezoidal threads is used to raise a load of 300 kN. The nominal diameter is 100 mm and the pitch is 12mm. The coefficient of friction at the screw threads is 0.15. Neglecting collar friction, calculate

- (i) torque required to raise the load
- (ii) torque required to lower the load and
- (iii) efficiency of the screw

2. Determine the diameter of ball in a linear motion guide way of length 60mm consisting of 12balls, when the maximum pressure acting on guide way is 5000N/mm^2 . Assume $K=0.6\text{N/mm}^2$.

Concept Map

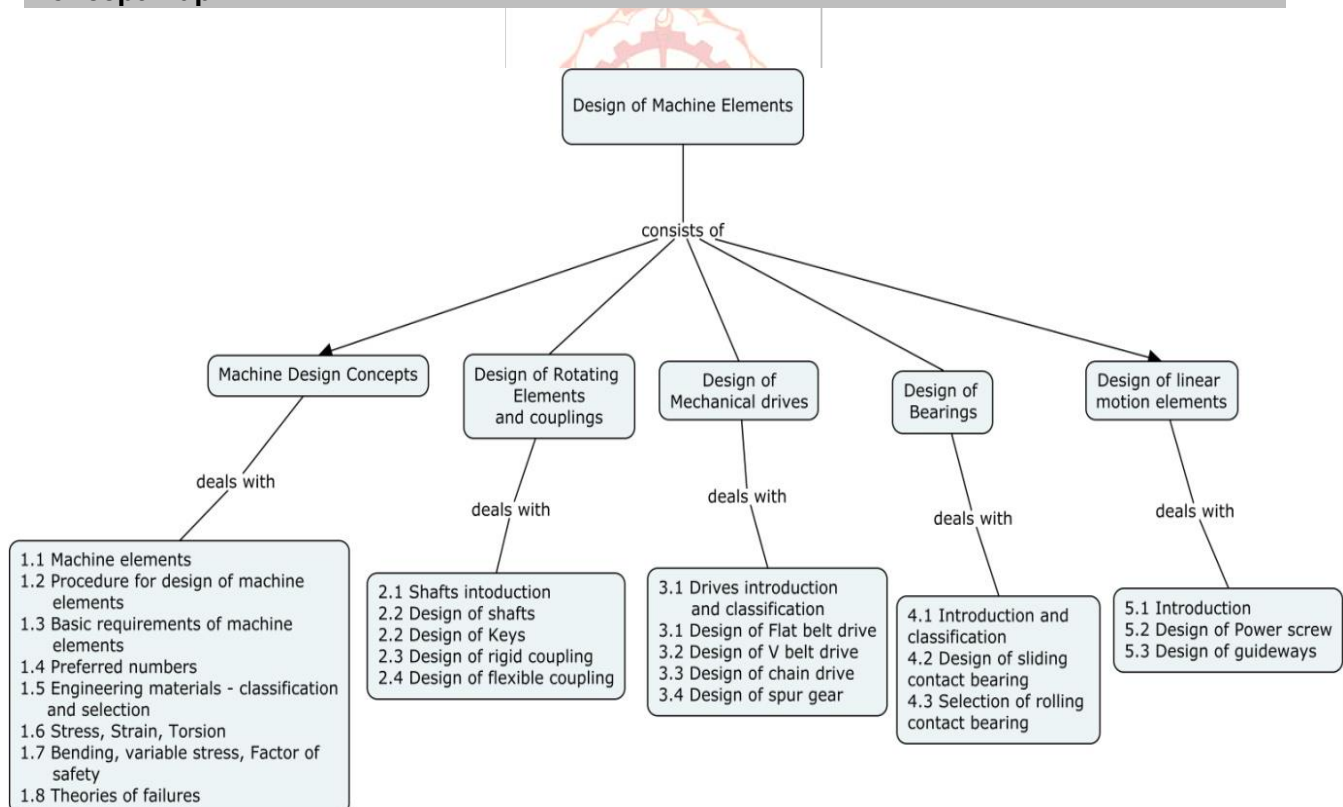

Syllabus

Machine Design Concepts: Machine Elements, Procedure for design of machine elements, Basic requirements of machine elements, Preferred Numbers, Engineering materials-properties and selection, Stress, Strain, Torsion, Bending, Variable stress, Factor of safety, Theories of failure.

Design of Rotating elements and couplings: Shafts, Shafts subjected to twisting moment, combined Bending and twisting moment with axial loads. Design of Keys for shafts. Design of couplings - Rigid couplings and Flexible couplings.

Design of Mechanical drives: Drives classification, Design of Flat belt drive, Design of V belt Drive, Design of chain drive, Design of Spur gear.

Design of Bearings: Introduction, Classification, Design of sliding contact bearing, Design of rolling contact bearing.

Design of Linear motion elements: Introduction, Design of power screws, Design of guide ways.

Text Book

1. V.B. Bhandari, "**Design of machine elements**", Fourth edition, Tata McGraw Hill, 2016.

Reference Books

1. Joseph Edward Shigley and Charles R. Misucke, "**Mechanical Engineering Design**", Tenth Edition, Tata McGraw Hill, 2015.
2. Robert L. Norton, "**Machine Design: An integrated Approach**", Third edition, Prentice Hall, 2005.
3. Sundarajamoorthy T.V. and Shanmugam. N, "**Machine Design**", Anuradha Publications, 2003.
4. K. Ganesh Babu, K.Srithar, "**Design of machine Elements**", MCGraw Hill Education, 2009.
5. Hall, Holowenko and Laughin, "**Theory and Problems of Machine Design**", Tata McGraw Hill Company, 2002.
6. Sharma P. C, and Agarwal D.K, "**Machine design**", S.K. Kataria and Sons, New Delhi, 2000.
7. M. F. Spotts, T. E. Shoup, "**Design of Machine Elements**", Eighth Edition, Pearson Education Asia, 2006.
8. Amit U Pawar, Apurav A Wagh and D U Patil, "**Design of Linear Motion Guideways**", International journal of Engineering Research and Science & Technology, Vol.2, No. 4, 2015.
9. PSG, "**Design Data Book**", 2014.

Course Contents and Lecture Schedule

Module No.	Topic	No. of Lectures
1	Machine design Concepts	
1.1	Machine elements	2
1.2	Procedure for design of machine elements	
1.3	Basic requirements of machine elements	
1.4	Preferred numbers	
1.5	Engineering materials- Its properties and selection	1
1.6	Stress, Strain, Torsion	1

1.7	Bending, variable stress, Factor of safety	1
1.8	Theories of failure	2
	Tutorial	1
2	Rotating Elements and Couplings	
2.1	Shafts, Shafts subjected to Twisting moment and Combined Bending and Twisting moment	1
2.2	Shafts subjected to Combined Bending and Twisting moment with axial loads	1
2.3	Design of Keys for shafts	1
2.4	Design of rigid couplings	2
2.5	Design of flexible couplings	2
	Tutorial	1
3	Design of Mechanical drives	
3.1	Drives introduction and its classification	1
3.2	Design of Flat belt drive	2
3.3	Design of V-belt drive	2
3.4	Design of chain drive	2
3.5	Design of spur gear	2
	Tutorial	1
4	Design of Bearings	
4.1	Introduction and classification	1
4.2	Design of sliding contact bearing	2
4.3	Selection of rolling contact bearing	2
	Tutorial	1
5	Design of Linear motion elements	
5.1	Introduction	1
5.2	Design of Power screws	2
5.3	Design of Guide ways	1
	Tutorial	1
Total		37

Course Designers

1. Dr. G. Kanagaraj
2. Ms. T. R. Viveki

gkmech@tce.edu
trvmect@tce.edu

Preamble

The overall goal of this course is for students to attain a broad familiarity with many different sensors. Develop judgment of what sensors and modalities are appropriate for different applications and to Know how electronically condition the sensor, Students will learn measurement of physical parameters using various transducers and working of sensors. They will become familiar with operation of measuring instruments and their applications.

Prerequisite

14MT440- Metrology and Mechanical Measurements

14MT430- Analog and Digital circuits

Course Outcomes

On the successful completion of the course, students will be able to

CO1	Explain the characteristics of different type of sensors and its specifications	Understand
CO2	Choose appropriate sensor for the required applications	Apply
CO3	Design suitable sensor for the given situation	Apply

Mapping with Programme Outcomes

COs	PO1	PO2	PO3	PO4	PO5	PO6	PO7	PO8	PO9	PO10	PO11	PO12
CO1	S	M	L	M	L				M		M	
CO2	S	S	S	S	S				M		M	S
CO3	S	S	S	M	M				M		M	S
CO4	S	S	S	S	L				S		M	S

S- Strong; M-Medium; L-Low

Assessment Pattern

Bloom's Category	Continuous Assessment Tests			Terminal Examination
	1	2	3	
Remember	-	-	-	-
Understand	40	40	40	40
Apply	60	60	60	60
Analyse	0	0	0	0
Evaluate	0	0	0	0
Create	0	0	0	0

Course Level Assessment Questions**Course Outcome 1 (CO1):**

- 1) Compare thermocouple, thermistor, RTD and pyrometer based on the working and range of operation.
- 2) A thermometer is initially at room temperature of 23 deg C. it is immersed in an oil bath at 151° C. After 3 seconds it shows a reading of 95 deg c. find its time constant. After what time from the start will be thermometer read 150° C.
- 3) Discuss the various mounting methods of strain gauge for force measuring applications.
- 4) Compare the cons and pros of inductive and resistance type level sensors.
- 5) Define law of intermediate metal and law of intermediate temperature.

Course Outcome 2 (CO2):

- 1) Select the suitable measuring technique for high speed turbine. The process parameters such as angular velocity and acceleration should be recorded.
- 2) Select the proper measuring technique to analyze the vibration of cantilever beam. Justify your selection.
- 3) The body temperature of patient should be monitored 24 x7. Decide an appropriate temperature measuring sensor.
- 4) Select an appropriate level sensor to maintain the coolant level in the boiler.

Course Outcome 3 (CO3):

1. Construct an weighing system that uses load cell and explain its functioning for measurement of materials carried in a truck from harbor.
2. Design a strain-gauge thrust transducer for small experimental rocket engines which are roughly in shape of a cylinder 6 inch in diameter by 12 inch long. The following information is given:
 - i. Weight of motor and mounting bracket, 20lbf.
 - ii. Maximum steady thrust, 50 lbf.
 - iii. Oscillating component of thrust, ± 10 lbf maximum.
 - iv. Oscillating components of thrust up to 100 Hz must be measured with a flat amplitude ratio within $\pm 5\%$.
 - v. A recorder with the sensitivity of 0.1V/in, frequency response flat to 120 Hz and input resistance of 10,000 Ω is available.
 - vi. Thrust changes of 0.5 lbf must be clearly detected.
 - vii. Gauges with a resistance of 120 Ω and gauge factor of 2.1 are available. They are 0.5x0.1 inch in size.
 - viii. An amplifier (to be placed between transducer and recorder) is available with a gain up to 1,000.

Design the transducer as so to require a minimum of amplifier gain. If damping is employed, calculate the required damping coefficient B, but do not design the damper. Use the cantilever-beam arrangement below.

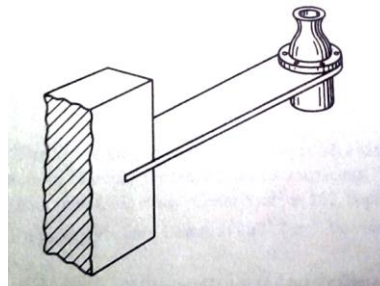

Concept Map

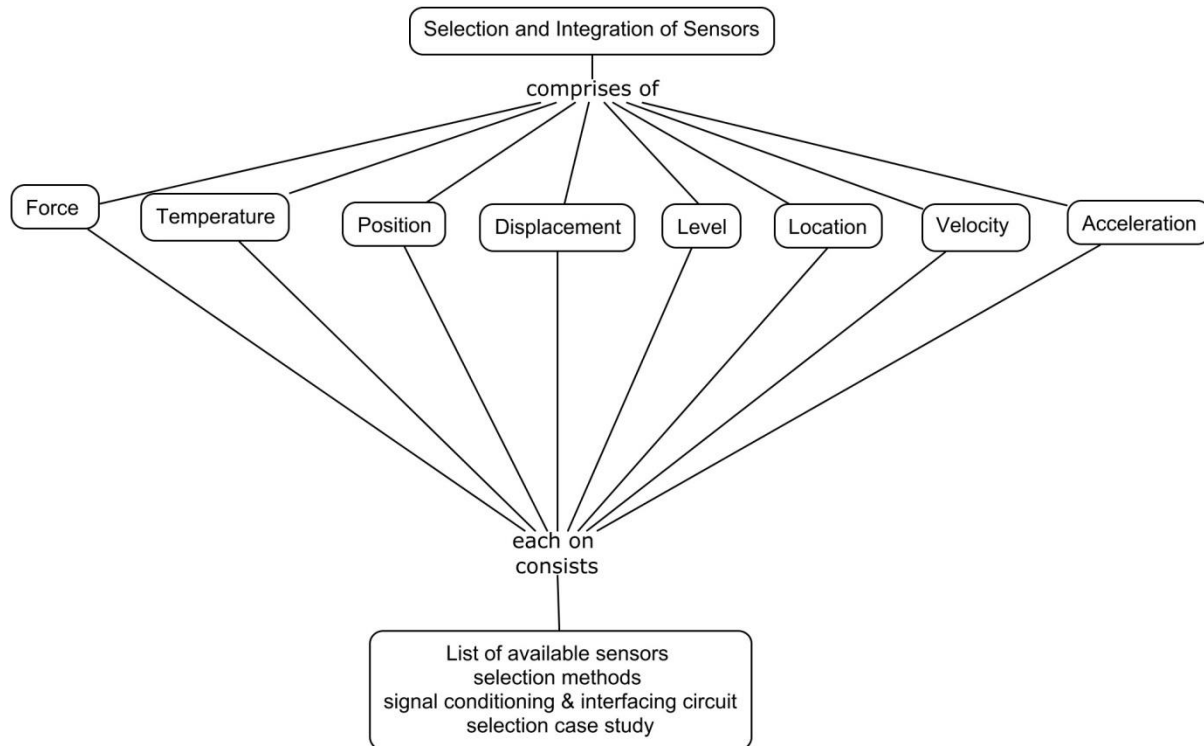

Syllabus

Force sensors: List of available sensors for force measurement, selection methods of force sensors, signal conditioning, interfacing circuit, selection of force sensors: Determine the stress situation near a pressure vessel nozzle.

Temperature sensor: List of available sensors for temperature measurement, selection methods of temperature sensors, signal conditioning, interfacing circuit, Selection of temperature sensors: temperature measurement inside the boiler, room temperature measurement

Position, Displacement, and Level: List of available Position, Displacement, and Level sensors, selection methods of Position, Displacement, and Level sensors, signal conditioning, interfacing circuit, selection case study.

Location sensors: List of available location sensors, selection methods of location sensors, signal conditioning, interfacing circuit, selection case study.

Velocity and Acceleration: List of available velocity and acceleration sensors, selection methods of velocity and acceleration sensors, signal conditioning, interfacing circuit, selection case study.

Text Book

1. Jacob Fraden, "**Hand book of Modern sensors, Physics, Design and Applications**", Third edition, Springer, 2004.
2. Bela G. Liptak, "**Process Measurement and Analysis volume I**", Fourth edition, CRC Press, 2003.

Reference Books

1. Ernest O Doebelin "**Measurement Systems Application and Design**" Tata McGraw Hill Edition, 2004.
2. Sabrie Solomon, "**Sensors and control systems in manufacturing**", McGraw Hill international Editions, 1994.
3. Singh S.K., "**Industrial Instrumentation and Control**", Tata McGraw Hill Edition, 2003.

Course Contents and Lecture Schedule

Module No.	Topic	No. Of Lectures
1	Force sensors	
1.1	List of available sensors for force measurement	2
1.2	Selection methods of force sensors, signal conditioning	2
1.3	Interfacing circuit, selection of force sensors: Determine the stress situation near a pressure vessel nozzle.	2
2	Temperature sensor	
2.1	List of available sensors for temperature measurement	2
2.2	Selection methods of temperature sensors	2
2.3	Signal conditioning, interfacing circuit	2
2.4	Selection of temperature sensors: temperature measurement inside the boiler	1
2.5	Room temperature measurement	1
3	Position, Displacement, and Level	
3.1	List of available Position, Displacement, and Level sensors	2
3.2	Selection methods of Position, Displacement, and Level sensors	2
3.3	Signal conditioning, interfacing circuit	2
3.4	Selection case study	2
4	Location sensors	
4.1	List of available location sensors	2
4.2	Selection methods of location sensors	2
4.3	Signal conditioning, interfacing circuit	2
4.4	Selection case study	2

5	Velocity and Acceleration	
5.1	List of available velocity and acceleration sensors	2
5.2	Selection methods of velocity and acceleration sensors	2
5.3	Signal conditioning, interfacing circuit	2
5.4	Selection case study	2
TOTAL		38

Course Designers:

1. Dr. L.R.Karl Marx lrkarlmarx@tce.edu
2. Ms. S. Sivapriya ssmect@tce.edu



14MTGA0 INDUSTRIAL AUTOMATION

Category	L	T	P	Credit
GE	3	0	0	3

Preamble

Automation, possibly more aptly termed automation engineering, is a design engineering philosophy that is directed toward enhancing the automatic nature (sometimes called automaticity) of a machine, process, or other type of work system'. The objective of automation is to cause the work system to be as automatic, that is, self-acting, self-regulating, and self-reliant, as may be possible-but against the practical backdrop of various economic, environmental, social, and other restraints. Because of these restraints, the work systems are only partially automated.

Numerous scientific and engineering disciplines make up the technical foundation for automation. Very prominent are electronics; electrical, mechanical, chemical, metallurgical, and industrial engineering; measurement and control technology; computer, information, and communication sciences-all supported by the principles of physics and mathematics. As is essentially true of all business concerns, automation is welcomed most where it contributes to profit. Of the several dividends yielded by manufacturing processing automation, two are uppermost improved productivity and better product quality. This course gives insight in to various automation components, its functions and utilization for effective and efficient realization of automated systems.

Prerequisite

NIL

Course Outcomes

On successful completion of the course, students will be able to

CO1.	Describe the working principles, characteristics and selection criteria, control methods of different automation components like PLC, SCADA, DCS and communication buses.	Understand
CO2.	Explain the construction, working and control strategies of different industrial drives.	Understand
CO3.	Construct a program using PLC to solve problems pertaining to automation industries.	Apply
CO4.	Design a automation cell by interconnecting work cell devices through a network.	Apply

Mapping with Programme Outcomes

COs	PO1	PO2	PO3	PO4	PO5	PO6	PO7	PO8	PO9	PO10	PO11	PO12
CO1.	M	M	M	S	M	M	-	M	M	-	-	S
CO2.	M	M	S	S	M	M	-	M	S	S	M	S
CO3.	S	S	S	S	S	S	S	S	S	S	M	S
CO4.	S	S	S	S	S	S	S	S	S	S	M	S

S- Strong; M-Medium; L-Low

Assessment Pattern

Bloom's Category	Continuous Assessment Tests			Terminal Examination
	1	2	3	
Remember	20	20	20	20
Understand	50	50	50	50
Apply	30	30	30	30
Analyse	-	-	-	-
Evaluate	-	-	-	-
Create	-	-	-	-

Course Level Assessment Questions

Course Outcome 1 (CO1):

1. Explain parts of PLC with neat diagram.
2. Explain the I/O Modules of PLC.
3. Explain the architecture of DCS System.
4. Explain the components of SCADA System.

Course Outcome 2 (CO2):

1. Explain the use of pressure control valve in hydraulic circuits.
2. List the types of directional control valves available in fluidic systems.
3. Explain the V/F method of speed control in Induction motor drive.
4. Explain the elements of Servo control.

Course Outcome 3 (CO3):

1. Design a ladder and hardware connection diagram for forward-reverse running of 3-phase Induction Motor with mutual interlock.
2. Write a PLC program to alternatively switch on and off a pump with a time delay of 5 sec. Also provide indication to show the on- off status of a pump.
3. Write a PLC program to start a second conveyor after a count of 10 pallets from first conveyor.
4. Write a PLC program to control the speed of the induction motor using PLC and VFD drive.

Course Outcome 4 (CO4):

1. Select and explain the communication protocol for interconnecting pick and place robot , CNC controller ,ASRS system and conveyor in an automated work cell.
2. Design a hydraulic sequence circuit for controlling two cylinders with a logic of A+B+A-B- using PLC.
3. Design a automated work cell to control two servo Motors in master/Slave mode using PLC and Servo drive.

Concept Map

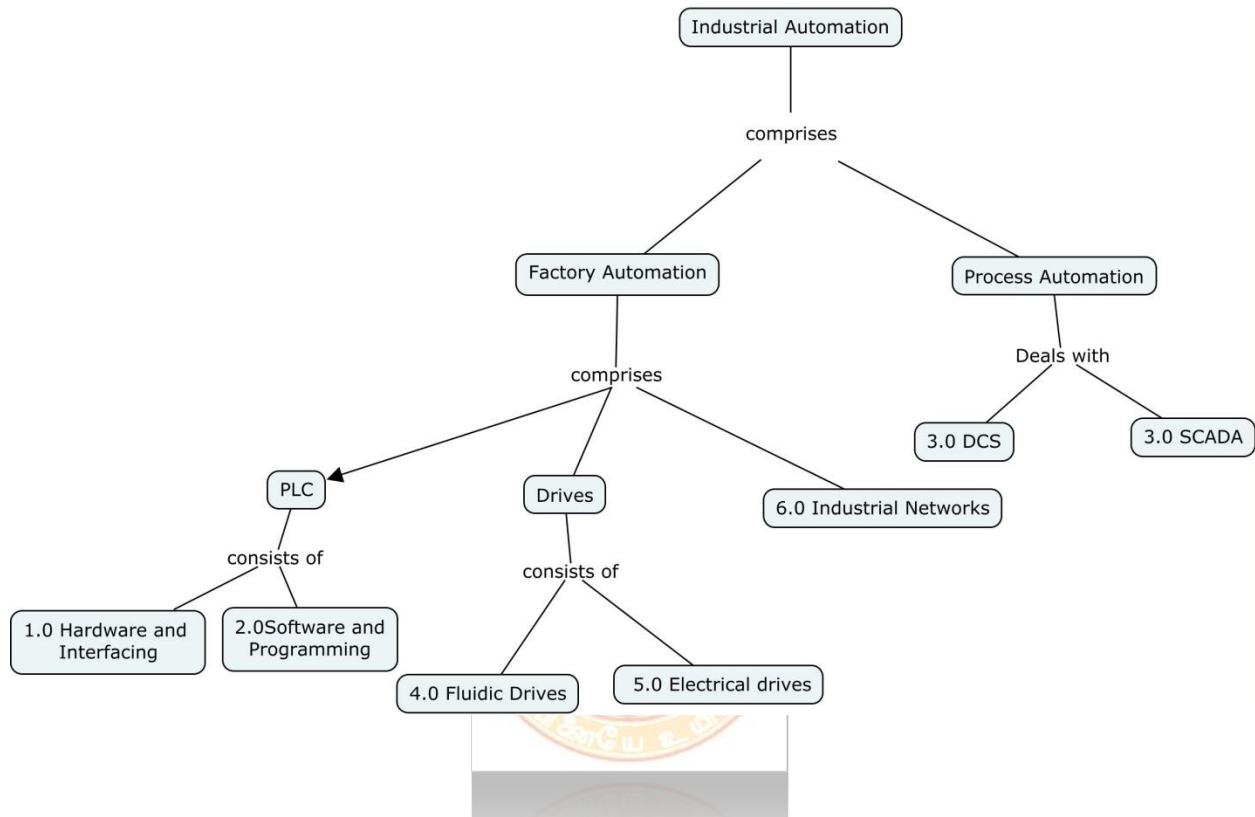

Syllabus

PLC Basics: Parts of a PLC -Principles of Operation –Advantages and Disadvantages of PLC - PLC Size and Application- The I/O Section -Discrete I/O Modules-Analog I/O Modules-Special I/O Modules – I/O Specifications-Scanning cycle of PLC-The CPU-Memory Design-Memory Types

Programming PLC: Processor Memory Organization- PLC Programming Languages- PLC Modes of Operation- Relay-Type Instructions- Instruction Addressing-Branch Instructions Internal Relay Instructions Programming EXAMINE IF CLOSED and EXAMINE IF OPEN Instructions- Designing a Ladder Diagram for large process –Programming Timers-Programming counters-programming Analog module -HMI programming-Interfacing PLC with HMI

DCS and SCADA: Basic concepts of Distributed Computing-Evolution of Distributed Computing System-Present market trends in DCS-Basic DCS specification-General description of commercial DCS -Advantage of DCS systems -DCS selection criteria - DCS architecture.

Basics of SCADA system-SCADA key features - Remote terminal units (RTUs)-Typical requirements for an RTU system - PLCs used as RTUs-Consideration and benefits of SCADA system- DCS versus SCADA terminology-SCADA software package.

Fluidic Drives in Automation: Fundamentals of hydraulic and pneumatic drives-basic definitions and principles-benefits of fluidic drives-components of fluidic drive systems-Control valves Classification-Pressure, Directional, Proportional and servo valves-Basic Fluidic circuits.

Electric Drives in automation: Induction motor drive: V/F Control, Direct torque control, VFD Configuration & Programming, Stepper motor drive, objectives of servo control, Elements of servo control, Structure of servo control

Industrial Networks: Profibus, Field bus, Sercos, Ethernet, Application of Wireless Networks for Industrial automation – Basics of Industry4.0

Text Book

1. Frank D petruzella, "**Programmable logic controllers**", Fourth edition, McGraw Hill higher education ,2016
2. Rajesh Mehra (Author), Vikrant Vij (Author), "**PLCs & SCADA: Theory and Practice**", Laxmi Publications-2016
3. Steve Mackay ,Edwin Wright MIPENZ, Deon Reynders, John Park "**Practical Industrial Data Networks -Design, Installation, trouble shooting**" ,IDC Technologies, Australia.
4. Frank D petruzella, "**Electrical Motor and control systems**", McGraw Hill higher education ,2010

Reference Books

1. Krishna Kant –"**Computer Based Industrial Control**", EEE-PHI, 2nd edition, 2010.
2. Garry Dunning-**Introduction to Programmable Logic Controllers**, 2nd edition, Thomson, ISBN: 981-240-625-5.
3. W.Bolton- **Programmable Logic Controllers**, Sixth Edition (Paperback) ISBN-13: 978-0128029299, 2012.

Course Contents and Lecture Schedule

Sl.No.	Topic	No. of Lectures
1.0	PLC Basics	
1.1	Parts of PLC, Principles of Operation, Advantages and Disadvantages of PLC.	1
1.2	PLC Size and Application- The I/O Section -Discrete I/O Modules	1
1.3	Analog I/O Modules-Special I/O Modules – I/O Specifications	1
1.4	Scanning cycle of PLC-The CPU-Memory Design-Memory Types	1
2.0	Programming PLC	
2.1	Processor Memory Organization- PLC Programming Languages- PLC Modes of Operation	1

Sl.No.	Topic	No. of Lectures
2.2	Relay-Type Instructions- Instruction Addressing-Branch Instructions Internal Relay Instructions	1
2.3	Programming EXAMINE IF CLOSED and EXAMINE IF OPEN Instructions	1
2.4	Designing a ladder diagram for Large Process	1
2.5	Programming Timers	2
2.6	Programming Counters	2
2.7	Programming Analog module	1
2.9	HMI programming-Interfacing PLC with HMI	1
3.0	DCS and SCADA	
3.1	Basic concepts of Distributed Computing-Evolution of Distributed Computing System-	1
3.2	Present market trends in DCS-Basic DCS specification	1
3.3	General description of commercial DCS -Advantage of DCS systems - DCS selection criteria	1
3.4	DCS architecture.	1
3.5	Basics of SCADA system-SCADA key features	1
3.6	Remote terminal units (RTUs)-Typical requirements for an RTU system	1
3.7	PLCs used as RTUs-Consideration and benefits of SCADA system	1
3.8	DCS versus SCADA terminology-SCADA software package	1
4.0	Fluidic Drives in Automation	
4.1	Fundamentals of hydraulic and pneumatic drives	1
4.2	Basic definitions and principles-benefits of fluidic drives	1
4.3	Components of fluidic drive systems	1
4.4	Control valves Classification-Pressure, Directional, Proportional and servo valves.	2
4.5	Basic Fluidic Circuits	1
5.0	Electric Drives in automation	
5.1	Induction motor drive: V/F Control, Direct torque control,	1
5.2	VFD Configuration & Programming	1

Sl.No.	Topic	No. of Lectures
5.3	Stepper motor drive	1
5.4	objectives of servo control, Elements of servo control, Structure of servo control	2
6.0	Industrial Networks	
6.1	Profibus, Field bus	1
6.2	Sercos, Ethernet	1
6.4	Application of wireless network for industrial automation	1
6.5	Basics of Industry4.0	1
TOTAL		36

Course Designers

1. H.Ramesh rameshh@tce.edu
2. S.Julius Fusic sjf@ tce.edu



14MTGB0**MECHATRONICS**

Category	L	T	P	Credit
GE	3	0	0	3

Preamble

Mechatronics is the synergistic combination of mechanical and electrical engineering, computer science, and information technology, which includes the use of control systems as well as numerical methods to design products with built-in intelligence.

The subject involves study of sensors, actuators, controlling mechanism/algorithm and common Mechatronics applications. The students would be able to understand the synergistic combination of all the aspects of Mechatronics which would be useful in developing a particular application.

Prerequisite

Nil

Course Outcomes

On successful completion of the course, students will be able to

CO1	Describe the common sensors and actuators used in Mechatronic systems	Understand
CO2	Elucidate control mechanisms used in Mechatronic systems	Understand
CO3	Develop PLC ladder programming and implementation of logics.	Apply
CO4	Implement the concepts for particular application	Apply

Mapping with Programme Outcomes

COs	PO1	PO2	PO3	PO4	PO5	PO6	PO7	PO8	PO9	P10	P11	P12
CO1	L	M	S	S	-	-	S	-	-	M	L	S
CO2	L	L	S	S	-	S	-	-	-	M	L	S
CO3	L	S	L	M	M	M	-	-	-	L	L	M
CO4	L	S	L	M	L	S	M	-	-	L	L	L

S- Strong; M-Medium; L-Low

Assessment Pattern

Bloom's Category	Continuous Assessment Tests			Terminal Examination
	1	2	3	
Remember	20	20	20	20
Understand	20	20	20	40
Apply	60	60	60	40
Analyse	-	-	-	-
Evaluate	-	-	-	-
Create	-	-	-	-

Course Level Assessment Questions

Course Outcome 1 (CO1):

1. List the types of position sensors.
2. Explain the significance of Variable Reluctance sensor.
3. Elucidate the difference of RTD from Thermocouple.
4. Explain the different types of strain gauges.
5. Illustrate DC motor to be used as an actuator.

Course Outcome 2(CO2):

1. Discuss about the steps to obtain a transfer function from a physical system.
2. List the advantages of PID controller.
3. Describe about the effect of step signal on first order systems.
4. Explain the time domain analysis of first order system.

Course Outcome 3 (CO3):

- 1.

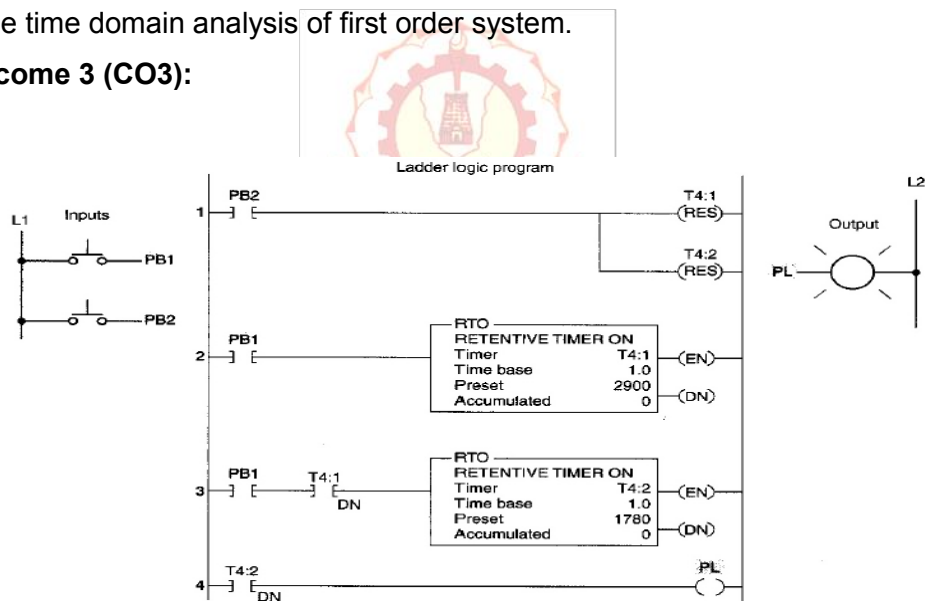

Study the ladder logic program in the figure and answer the questions that follow:

- a. State the purpose of interconnecting the two timers?
 - b. Calculate the time elapsed before output PL is energized?
 - c. List the two conditions must be satisfied for timer T4:2 to start timing
 - d. Assume that putput PL is ON and power to the system is lost. Consider power is restored, predict the status of this output.
 - e. Assume input PB2 is ON, discuss the consequences.
 - f. Assume input PB1 is ON, Calculate the accumulated time elapsed before rung 3.
2. Write a program to implement the process illustrated in the following figure. The sequence of process is to be as follows:

- a. Normally open and normally closed stop push buttons are used to start and stop the process.
- b. Assume the start button is pressed, solenoid A energizes to start filling the tank.
- c. As the tank fills, the empty level sensor switch closes.
- d. Consider the tank is full, the full level sensor switch closes.
- e. Solenoid A is de energized.
- f. The agitate motor starts and runs for 3 min to mix the liquid.
- g. As the agitate motor stops, solenoid B is energized to empty the tank.
- h. As the tank is completely empty, the empty sensor switch opens to de-energize solenoid B.
- i. The start button is pressed to repeat the sequence.

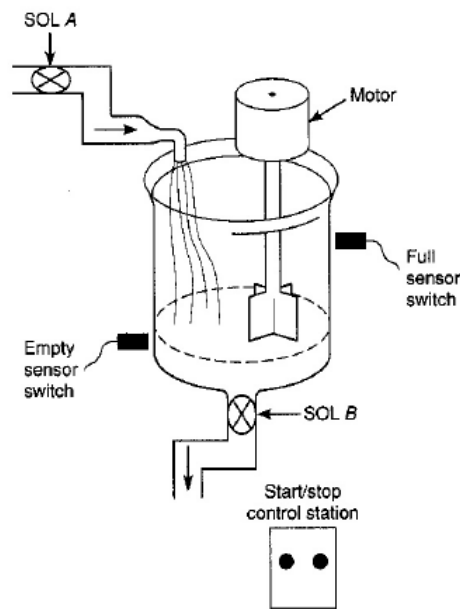

Course Outcome 4 (CO4):

1. Design a floor mounted, 3 axes pick and place robot which has a payload of 4 kg and reach of 1.5m. The robot main axis which has a length of 20cm can rotate from 0 to 280 degrees clockwise and anticlockwise by a 12V DC motor. A link of length 8 cm is connected to the main axis. It is connected to a gripper at the end, to pick. The link which moves along the main axis and the gripper works by use of pneumatic cylinders operated by solenoid controlled valves with limit switches. The solenoids of the pneumatic cylinders are controlled by a microcontroller. Discuss the architecture of the design and control mechanism.
2. Design a car parking barrier system driven by a 24V DC motor controlled by a PLC. The car IN side is controlled by a sensor, which detects the coin put and sends input to open the barrier. Two solenoid operated pneumatic valves are controlled to pull up and lower the

barrier. The car OUT side consists of the same arrangement which gets input from a camera, which senses the number. Develop a suitable PLC control logic and design.

Concept Map

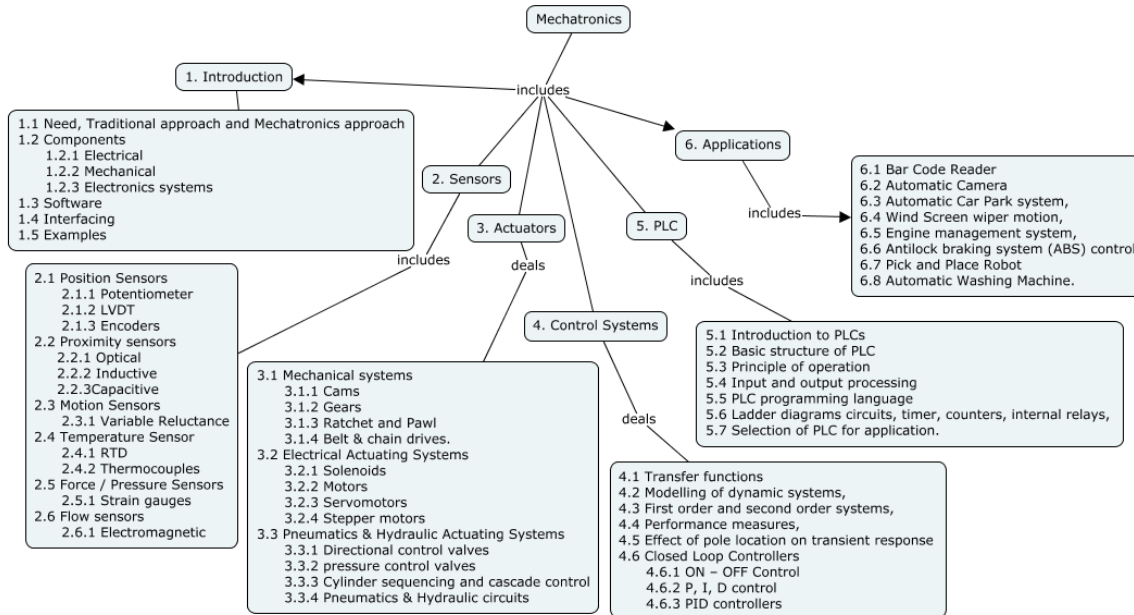

Syllabus

Introduction to Mechatronics: Introduction, Need, Traditional approach and Mechatronics approach, Components-Electrical, Mechanical, Electronics systems, Software, Interfacing. Examples.

Sensors: Position Sensors: - Potentiometer, LVDT, Encoders; Proximity sensors: - Optical, Inductive, Capacitive; Motion Sensors: - Variable Reluctance; Temperature Sensor: RTD, Thermocouples; Force / Pressure Sensors: - Strain gauges; Flow sensors: - Electromagnetic

Actuators: Mechanical Actuating Systems: Mechanical systems - Cams, Gears, Ratchet and Pawl, Belt & chain drives. Electrical Actuating Systems - Solenoids, DC Motors, Servomotors, Stepper motors. Pneumatics & Hydraulic Actuating Systems: Directional control valves, pressure control valves, cylinder sequencing and cascade control, Pneumatics & Hydraulic circuits

Control Systems: Transfer functions, Modelling of dynamic systems, First order and second order systems, Performance measures, Effect of pole location on transient response, **Closed Loop Controllers:** ON – OFF Control, P, I, D control and PID controllers.

Programmable Logic Controller: Introduction to PLCs, Basic structure of PLC, Principle of operation, input and output processing, PLC programming language, ladder diagram, ladder diagrams circuits, timer, counters, internal relays, selection of PLC for application.

Applications: Bar Code Reader, Automatic Camera, Automatic Car Park system, Wind Screen wiper motion, Engine management system, Antilock braking system (ABS) control, Pick and Place Robot and Automatic Washing Machine.

Text Books

1. Richard C. Dorf, Robert H. Bishop, "**Modern Control Systems**" Twelfth Edition, Pearson Education, 2014.
2. W. Bolton, "**Mechatronics – Electronic control systems in Mechanical & Electrical Engineering**", Pearson Education Ltd., 2003.
3. Shetty and Kolk, "**Mechatronics System Design**", Cengage learning, India, second edition, 2011.

Reference Books

1. M.Gopal, "**Control systems: Principles and Design**", Fourth edition, McGraw Hill education Private Limited, 2014.
2. David M. Auslander, Carl J. Kempf, "**Mechatronics: Mechanical System Interfacing**", prentice hall, (1996).

Course Contents and Lecture Schedule

Sl.No.	Topic	No. of Lectures
1	Introduction to Mechatronics	
1.1	Introduction, Need, Traditional approach and Mechatronics approach	1
1.2	Components-Electrical	1
1.3	Mechanical, Electronics systems	1
1.4	Software, Interfacing. Examples	1
2	Sensors	
2.1	Position Sensors - Potentiometer, LVDT, Encoders	1
2.2	Proximity sensors - Optical, Inductive, Capacitive	1
2.3	Motion Sensors - Variable Reluctance	1
2.4	Temperature Sensor - RTD, Thermocouple	1
2.5	Force / Pressure Sensors - Strain gauges	1
2.6	Flow sensors: - Electromagnetic	1
3	Actuators	
3.1	Mechanical systems - Cams, Gears, Ratchet and Pawl, Belt & chain drives.	1
3.2	Electrical Actuating Systems - Solenoids, DC Motors, Servomotors, Stepper motors.	1
3.3	Pneumatics & Hydraulic Systems - Directional control valves, pressure control valves, Process control valves, ,	1
3.4	Cylinder sequencing and Cascade control	1

Sl.No.	Topic	No. of Lectures
3.5	Identifications of graphical symbols for Pneumatic and Hydraulic circuits	1
4	Control Systems	
4.1	Transfer functions, Mathematical model of physical system	1
4.2	Open loop and closed loop control	1
4.3	PID controllers	1
4.4	Time domain analysis	1
4.5	Modelling of dynamic systems	1
4.6	Effect of pole location on transient response	1
5	Programmable Logic Controller	
5.1	Introduction to PLCs, Basic structure of PLC	1
5.2	Principle of operation, input and output processing,	1
5.3	PLC programming language, ladder diagram	1
5.4	Ladder diagrams circuits	1
5.5	Timer, Counters, Internal relays	1
5.6	Selection of PLC for application	1
6	Applications	
6.1	Automatic Car parking system, Boat – Autopilot Coin counter	1
6.2	High-Speed Tilting trains, Automatic Car Park system	1
6.3	Engine management system, Antilock braking system (ABS) control	1
6.4	Traffic controller and Automatic Washing Machine	1
Total Hours		39

Course Designers:

- | | | |
|------------------|---|----------------------|
| 1. Mr T Vivek | - | tvivek@tce.edu |
| 2. Mr M.A Ganesh | - | ganeshma2015@tce.edu |

14MTGC0 TOTAL QUALITY MANAGEMENT

(Common with 14MTPF0– Total Quality management)

Preamble

Quality is the mantra for success or even for the survival of any organization to have continuous Quality Improvement, customer focus and teamwork. Total Quality Management (TQM) is an enhancement to the traditional way of doing business. It is a proven technique to guarantee survival in world-class competition. It integrates fundamental management techniques, existing improvement efforts, and technical tools under a disciplined approach. At the end of the course the students are expected to recognize the quality issues in an organization and analyze the ways to solve those using TQM techniques, and demonstrate skills in using modern TQM tools and software to analyze problems.

Prerequisite

- NIL

Course Outcomes

On the successful completion of the course, students will be able to,

CO 1.	Evaluate the principles of quality management and to explain how these principles can be applied within quality management systems.	Understand
CO 2.	Identify the aspects of the quality improvement cycle by applying QC, 5S and KAIZEN	Apply
CO 3.	Select and use seven quality tools and explain the sampling plans	Apply
CO 4.	Apply techniques like QFD, FMEA, Benchmarking process for controlling, improving and measuring quality.	Apply
CO 5.	Illustrate various ISO standards and quality systems in an organization.	Understand

Mapping with Programme Outcomes

Cos	PO1	PO2	PO3	PO4	PO5	PO6	PO7	PO8	PO9	PO10	PO11	PO12
CO 1.	-	-	-	-	-	M	-	M	-	-	-	M
CO 2.	-	M	-	-	M	M	-	M	S	M	-	-
CO 3.	-	S	-	-	M	M	-	-	-	M	-	-
CO 4.	-	M	-	-	-	-	-	-	S	M	-	-
CO 5.	-	-	-	-	-	-	-	M	-	M	-	M

S- Strong; M-Medium; L-Low

Assessment Pattern**Assignment: One Mini Project for 10Marks**

Bloom's Category	Continuous Assessment Tests			Terminal Examination
	1	2	3	
Remember	20	20	20	20
Understand	60	30	30	30
Apply	20	50	50	50
Analyse	-	-	-	-
Evaluate	-	-	-	-
Create	-	-	-	-

Course Level Assessment Questions**Course Outcome 1 (CO1):**

1. List out the various dimensions of product and service quality.
2. Describe about various Quality Statements.
3. Explain the basic steps in bench marking process.
4. Explain about implementation stages of Quality circles.

Course Outcome 2 (CO2):

1. What are the important factors that a customer will think about while purchasing a product.
2. Explain how would you make the employees in an organization to work together to achieve the common goal.
3. Mention about work place management in terms of 5S.
4. Explain Kaizen.

Course Outcome 3 (CO3):

1. A machine is working to a specification of 12.58 ± 0.05 mm. A study of 50 consecutive pieces shows the following measurements put into 10 groups of 3 each:

1	2	3	4	5	6	7	8	9	10
12.62	12.63	12.62	12.61	12.59	12.57	12.57	12.58	12.61	12.56
12.60	12.56	12.56	12.66	12.58	12.63	12.56	12.57	12.60	12.59
12.62	12.60	12.57	12.62	12.57	12.60	12.61	12.60	12.62	12.62
12.61	12.59	12.58	12.61	12.59	12.60	12.59	12.60	12.60	12.58
12.65	12.60	12.63	12.60	12.56	12.59	12.59	12.61	12.65	12.54

- a) Determine Control Limits and draw \bar{X} and R chart.
 - b) Determine Process capability.
 - c) Does it appear that the machine is capable of meeting the specification requirements.
 - d) Calculate % defective if any.
 - e) Suggest possible way to reduce the percent defectives.
2. Following are the inspection results of magnets for 16 hours.

Hour	1	2	3	4	5	6	7	8	9
No. of magnets inspected	48	36	50	47	48	54	50	42	32
No. of defective units	5	5	0	5	0	3	0	1	5

- a) Construct appropriate control charts.
 - b) State whether the process is in statistical control.
 - c) Indicate the values that are out of control.
3. Suppose that a product is shipped in lots of size $N=5000$. The receiving inspection procedure used is single sampling with $n=50$ and $c=1$.
- a) Draw the type-A OC curve for the plan.
 - b) Draw the type-B OC curve for this plan and compare it to the type-A OC curve found in part (a).
 - c) Which curve is appropriate for the situation?

Course Outcome 4 (CO4):

1. Explain about new seven management tools.
2. Design a FMEA document by identifying the failure modes in Hole drilling process. In the process, Consider $S=5$, $O=9$, $D=4$, Find RPN. After action plan $S=5$, $O=1$, $D=1$. Recalculate RPN After Completion of Action Plans and Validate Improvements.
3. Build the house of quality matrix to show the inter relationship between the customer requirements and technical descriptors for a manufacturing system.

Course Outcome 5 (CO5):

1. Explain what is the need of ISO 9001: 2015 and how will you implement it in your organisation.
2. Explain about the environmental implications on the society. Discuss the mandatory items of ISO 14000.
3. Discuss about the requirements and the benefits of implementing OSHAS 18000.

Concept map

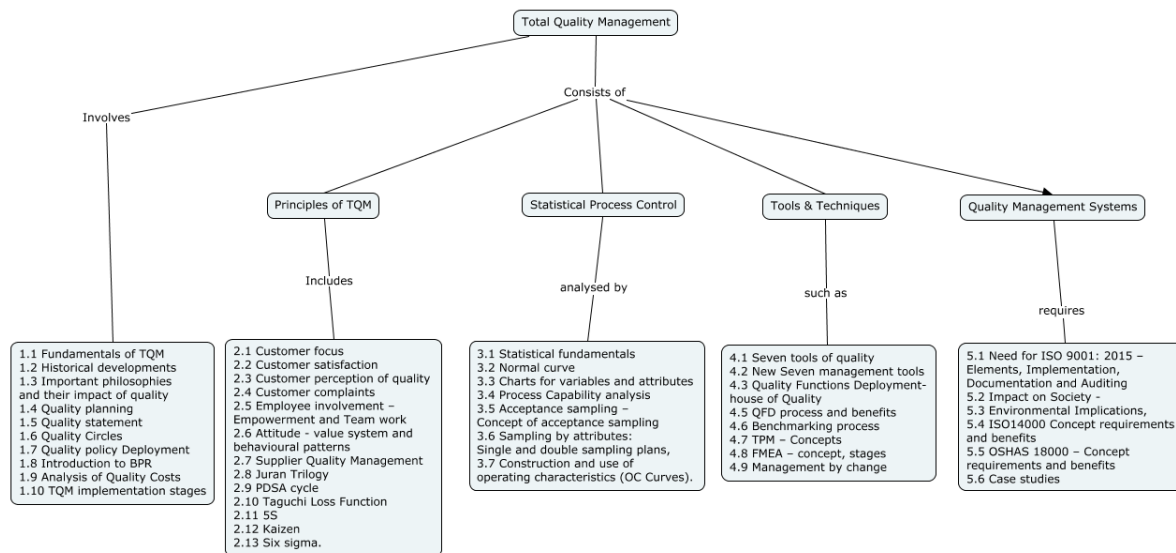

Syllabus

Introduction: Fundamentals of TQM – Historical developments – important philosophies- (Deming, Juran, Crosby, Ishikawa) and their impact of quality – Quality planning, Quality statement, Quality Circles, Quality policy Deployment, introduction to BPR and analysis of Quality Costs- TQM implementation stages

Principles of TQM: Customer focus - Customer satisfaction – customer perception of quality, customer complaints, Employee involvement – Empowerment and Team work, Attitude - value system and behavioural patterns, Supplier Quality Management, Juran Trilogy, PDCA cycle, Taguchi Loss Function, 5S, Kaizen, Six sigma.

Statistical Quality Control (SQC): Statistical fundamentals – Normal curve, charts for variables and attributes, Process Capability analysis, Acceptance sampling – Concept of acceptance sampling, Sampling by attributes: Single and double sampling plans, Construction and use of operating characteristics (OC Curves).

TQM Tools and Techniques: Seven tools of quality, New Seven management tools, Quality Functions Deployment (QFD) – house of Quality, QFD process and benefits, Benchmarking process, TPM – Concepts, FMEA – concept, stages, Management by change.

Quality Management Systems: Need for ISO 9001: 2015 – Elements, Implementation, Documentation and Auditing, Impact on Society - Environmental Implications, ISO14000 and OSHAS 18000 – Concept requirements and benefits – Case studies.

Text Books

1. Dale H.Besterfield, Carol Besterfield-Michna. Glen H. Besterfield and Mary Besterfield-Sacre., **“Total Quality Management”**, Pearson Education Asia, 3rd edition, 2011.
2. D.C.Montgomery, **“Introduction to Statistical Quality Control”**, John-Wiley & Sons Inc. New York, 6th edition, 2009

Reference Books

1. Amitava Mitra, "**Fundamentals of Quality control and Improvement**", John Wiley and Sons, Inc, New Jersey, 2016
1. Shridhara Bhat, "**TQM – Text and Cases**", Himalaya publishing House, 2002.
2. Janakiraman.B and Gopal .R.K, "Total Quality Management – Text and Cases", Prentice Hall(India) Pvt. Ltd., 2006.
3. James R.Evans and William M.Lindsay, "The management and control of Quality", 8th edition, 2012
4. Sharma, D.D, "**Total Quality Management**", Sultan Chand & Sons, 2005.

Course contents and Lecture schedule

No	Topic	No. of Lectures
1.0	Introduction	
1.1	Fundamentals of TQM – Historical developments	1
1.2	Important philosophies- (Deming, Juran, Crosby, Ishikawa) and their impact of quality –	2
1.3	Quality planning, Quality statement	1
1.4	Quality Circles	1
1.5	Quality policy Deployment	1
1.6	Introduction to BPR	1
1.7	Analysis of Quality Costs	1
1.8	TQM implementation stages	1
2.0	Principles of TQM	
2.1	Customer focus - Customer satisfaction, Customer perception of quality, customer complaints	1
2.2	Employee involvement – Empowerment and Team work	1
2.3	Attitude - value system and behavioural patterns	1
2.4	Supplier Quality Management	1
2.5	Juran Trilogy, PDSA cycle, Taguchi Loss Function	1
2.6	5S	1
2.7	Kaizen	1
2.8	Six sigma.	1
3.0	Statistical Quality Control (SQC)	
3.1	Statistical fundamentals- Normal curve	2

No	Topic	No. of Lectures
3.2	Charts for variables	1
3.3	Charts for attributes	1
3.4	Process Capability analysis,	1
3.5	Acceptance sampling – Concept of acceptance sampling, Sampling by attributes: Single and double sampling plans	2
3.6	Construction and use of operating characteristics (OC Curves).	1
4.0	TQM Tools and Techniques	
4.1	Seven tools of quality, New Seven management tools	1
4.2	Quality Functions Deployment (QFD) – house of Quality, QFD process and benefits	1
4.3	Benchmarking process	1
4.4	TPM – Concepts	1
4.5	FMEA – concept, stages	1
4.6	Management by change.	1
5.0	Quality Management Systems:	
5.1	Need for ISO 9001: 2015 – Elements, Implementation, Documentation and Auditing	1
5.2	Impact on Society - Environmental Implications	1
5.3	ISO14000 - Concept requirements and benefits	1
5.4	OSHAS 18000 – Concept requirements and benefits	1
5.5	Case studies.	1
	TOTAL	36

Course Designers:

1.Dr.M.Palaninatharaja
2.Mr.B.Praveen Kumar

pnatharaja@tce.edu
bpkmech@tce.edu

14MTGD0

SENSORS

Preamble

This course attempts to make the students familiar with sensor physics, characteristics and function. This course will enable the students to learn the basic principles of different sensors used in instruments/equipment used in the industry. Also student will get to know about various smart sensor and its techniques used for applying in crucial environments.

Prerequisite

Course Name: Analog and Digital Electronics.

Course Outcomes

On the successful completion of the course, students will be able to

CO1	Define sensors and its principles	Remember
CO2	Exemplify the characteristics of sensors	Understand
CO3	Sensor measurements and error calculations	Apply
CO4	Exemplify the functionality of sensors in instruments	Understand

Mapping with Programme Outcomes

Cos	PO1	PO2	PO3	PO4	PO5	PO6	PO7	PO8	PO9	PO10	PO11
CO1	L	L	L	S	S						L
CO2	L	L	L	S	S						L
CO3	M	M	L	S	S		M	M	M		M
CO4	M	M	M	S	S	S	S	S	S		S

S- Strong; M-Medium; L-Low

Assessment Pattern

Bloom's Category	Continuous Assessment Tests			Terminal Examination
	1	2	3	
Remember	30	30	30	30
Understand	50	50	50	50
Apply	20	20	20	20
Analyse	-	-	-	-
Evaluate	-	-	-	-
Create	-	-	-	-

Course Level Assessment Questions

Course Outcome 1 (CO1):

1. Define Accuracy.
2. How calibration is done for instruments?
3. Define resolution.

Course Outcome 2 (CO2):

1. How the calibration error can be measured?
2. How to sense the hysteresis?

3. State the nonlinearities present in a sensor measurements.

Course Outcome 3 (CO3):

1. Calculate the step size for a given input span of a sensor.
2. A force sensor has an output range of 1 to 5 V corresponding to an input range of 0 to 2×10^5 N. Find the equation of the ideal straight line.
3. A differential pressure transmitter has an input range of 0 to 2×10^4 Pa and an output range of 4 to 20 mA. Find the equation to the ideal straight line.

Course Outcome 4 (CO4):

1. Explain the bridge utilization of identifying the unknown strain.
2. Explain about the position sensing.
3. Discuss the role of MR and ER fluids as a dampers in automobiles.

Concept Map

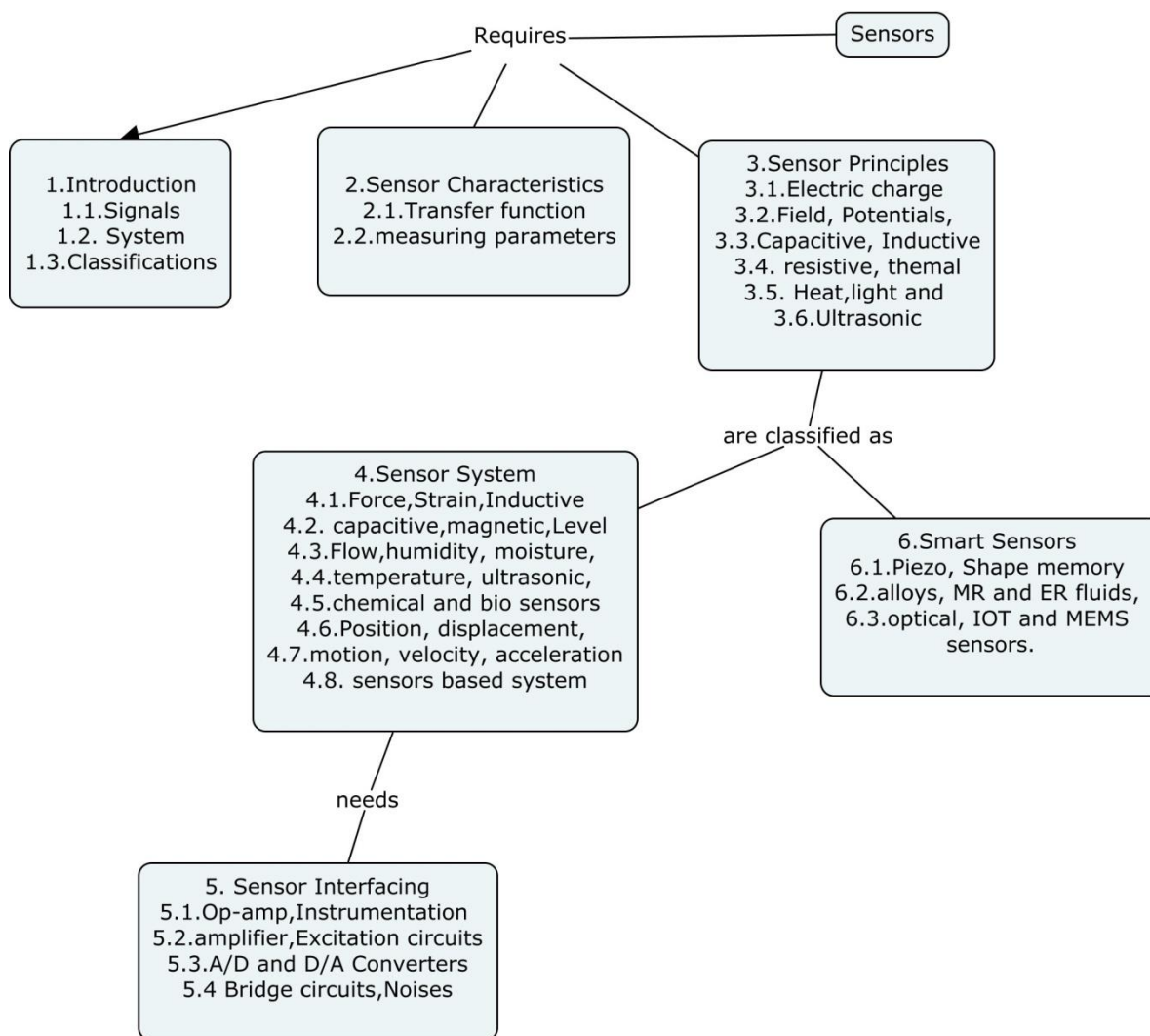

Syllabus

Introduction to Sensors: Sensor signals and systems, classification and measurement units.

Sensor Characteristics: Transfer function, measuring parameters.

Sensor Principles: Electric charge, field and potentials, capacitor and dielectric constant, magnetism, Induction, resistance, Seebeck, peltier and thermal effects, Heat transfer, light and ultrasonic.

Sensor Interfacing: op-amp and Instrumentation amplifier, Excitation circuits, A/D and D/A converters and bridge circuits. Noises in sensor circuits.

Sensor systems: force, strain, Inductive, capacitive, magnetic, level, Flow, pressure, acoustic, humidity, moisture, temperature, ultrasonic, chemical, image and bio sensors.

Position, displacement, motion, velocity, acceleration sensors based system.

Smart sensors: Piezo, Shape memory alloys, MR and ER fluids, optical, IOT and MEMS sensors.

Text Book/Learning Resources

1. Jacob Fraden, "**Hand book of modern sensors: Physics design and applications**", Springer, 2003, 3rd edition, AIP press.

Reference Books/Learning Resources

1. Ian R. Sinclair, "Sensors and transducers", Newness, Oxford, 2001, 3rd edition.
2. Doebelin E.O. and Manik D.N., "Measurement Systems", 6th Edition, Tata McGraw-Hill Education Pvt. Ltd., 2011.
3. John P. Bently, "Principle of measurement systems", Pearson education, Prentice Hall publication, 2004, 4th edition.
4. S.Renganathan, "Transducer Engineering", Allied publishers, New Delhi 2003.
5. Neubert, H.K.P., "Instrument Transducers – An Introduction to their Performance and Design", Oxford University Press, Cambridge, 2003.
6. Albert, D. Helfrick and Cooper, W. D., "Modern Electronic Instrumentation and Measurement Techniques", PHI Learning Pvt. Ltd., 2011.
7. Murthy, D.V.S., "Transducers and Instrumentation", 2nd Edition, Prentice Hall of India Pvt. Ltd., New Delhi, 2010.
8. Bolton, W., "Engineering Science", Elsevier Newnes, 5th Edition, 2006.
9. Patranabis, D., "Sensors and Transducers", 2nd Edition, Prentice Hall of India, 2010.

Course Contents and Lecture Schedule

Module No.	Topic	No. of Lectures
1.	Introduction to sensors	
1.1	Sensor signals and systems	1
1.2	Sensor classification	1
1.3	Sensor measurement units	1
2	Sensor Characteristics:	
2.1	Sensor Transfer function	1
2.2	Sensor characteristics measurements	2
3	Sensor Principles:	
3.1	Electric charge, field and potentials	1
3.2	capacitor and dielectric constant	1
3.3	Magnetic and Induction	1
3.4	Resistive, Seebeck, peltier and thermal effects	2
3.5	Heat transfer, light and ultrasonic	2
4	Sensor Interfacing:	
4.1	Op-amp and Instrumentation amplifier	2
4.2	Excitation circuits	2
4.3	A/D and D/A converters	2
4.4	Bridge circuits for sensors	2
4.5	Noises in sensor circuits	1
5	Sensor systems:	
5.1	Force, strain systems	2
5.2	Inductive, capacitive, magnetic systems	2
5.3	Level, Flow, pressure, acoustic systems	2
5.4	Humidity, moisture, temperature	2
5.5	Ultrasonic, chemical, image and bio sensors	2
5.6	Position, displacement, motion	2
5.7	Velocity, acceleration sensors based system	2
	Smart sensors:	
6.1	Piezo and SMA Sensors	2
6.2	MR and ER fluids, optical, IOT and MEMS sensors	2
	Total	40

Course Designer:

1. Dr. L.R. Karlmarx lrkarlmarx@tce.edu

Preamble

An elevator or lift is a type of vertical transportation that moves people or goods between floors (levels, decks) of a building, vessel, or other structure. Elevators are generally powered by electric motors that either drive traction cables or counterweight systems like a hoist, or pump hydraulic fluid to raise a cylindrical piston like a jack.

In agriculture and manufacturing, an elevator is any type of conveyor device used to lift materials in a continuous stream into bins or silos. Several types exist, such as the chain and bucket elevator, grain auger screw conveyor using the principle of Archimedes' screw, or the chain and paddles or forks of hay elevators.

Prerequisite

- Nil

Course Outcomes

On successful completion of the course, students will be able to

CO 1.	Understand the fundamentals of Elevator.	Understand
CO 2	Differentiate the control methods and choose according to the application.	Understand
CO 3.	Analyze the characteristics of elevator according to the application.	Apply

Mapping with Programme Outcomes

Cos	PO1	PO2	PO3	PO4	PO5	PO6	PO7	PO8	PO9	PO10	PO11	PO12
CO1.	M	-	S	-	-	-	-	-	-	-	-	M
C02.	M	-	M	-	-	-	-	-	-	-	-	M
CO3.	L	-	L	-	-	-	-	-	-	-	-	L

S- Strong; M-Medium; L-Low

Assessment Pattern

Bloom's Category	Continuous Assessment Tests	Terminal Examination
	1	
Remember	20	20
Understand	20	40
Apply	60	40
Analyse	-	-
Evaluate	-	-
Create	-	-

Course Level Assessment Questions

Course Outcome 1 (CO1):

1. Advantages of hydraulic elevators.
2. List the main components of Elevator
3. What are the types of pumps
4. What are the basic sensors used in an intelligent elevator.

Course Outcome 2(CO2):

1. Types of Encoders and differentiate them.
2. How will you choose a control method according to the application?
3. Consider an industrial application where elevator is used to lift construction materials.
Select a control method, components, drives and sensors to be used.
4. Describe the commutation of BLDC motors.
5. Explain with block diagram, the field oriented control of motor.

Course Outcome 3 (CO3):

1. How will you analyse the ride of an elevator.
2. Apply ride analysis using 3D Accelerometer to a roller coaster
3. Suggest other ways by which you can analyse the ride.
4. Use encoder, implement position and speed calculations and design a elevator.

Concept Map

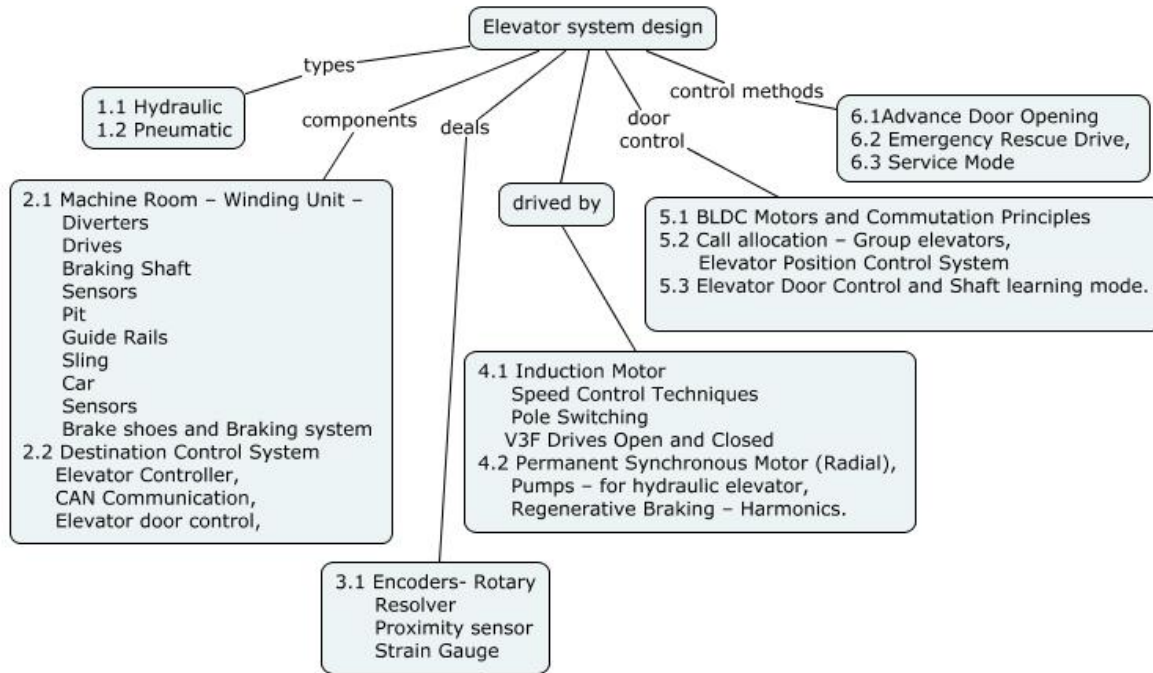

Syllabus

Types of Elevators

Electrical Construction, Advantage Hydraulic Construction, Advantage

Elevators Components

Machine Room – Winding Unit – Diverters – Drives – Braking Shaft – Sensors – Pit – Guide Rails – Sling – Car – Sensors – Brake shoes and Braking system with governors – Advanced - Destination Control System – Elevator Controller, CAN Communication, Elevator door control, door setup with dead weight.

Sensors

Encoders- Rotary- Resolver- Proximity sensor- Strain Gauge.

Hoisting Unit and Drives

Induction Motor – Speed Control Techniques – Pole Switching, V3F Drives Open and Closed loop, Permanent Synchronous Motor (Radial), Pumps – for hydraulic elevator, Regenerative Braking – Harmonics.

Door Controller and Elevator Control

BLDC Motors and Commutation Principles, Call allocation – Group elevators, Elevator Position Control System, Elevator Door Control and Shaft learning mode.

Elevator control and Ride Analysis with Safety Standards:

Advance Door Opening, Emergency Rescue Drive, Service Mode – Operation, Elevator Standards on noise, jerk, and acceleration. **Ride Analysis:** Elevator Ride Analysis with 3D Accelerometer.

Text Books

1. Elevator Engineering by Ben Abbaspour, EVB Publications, On 2010.
2. Elevators 101, 3rd Edition, by Zack McCain

Course Contents and Lecture Schedule

Module No.	Topic	No. of Lectures
1	Types of Elevators	
1.1	Electrical Construction, Advantage	1
1.2	Hydraulic Construction, Advantage	
2.	Elevators Components	
2.1	Machine Room – Winding Unit – Diverters – Drives – Braking Shaft – Sensors – Pit – Guide Rails – Sling – Car – Sensors – Brake shoes and Braking system with governors	1
2.2	Advanced - Destination Control System – Elevator Controller, CAN Communication, Elevator door control, door setup with dead weight.	1
3.	Sensors	
3.1	Encoders- Rotary- Resolver- Proximity sensor- Strain Gauge	1
4.	Hoisting Unit and Drives	
4.1	Induction Motor – Speed Control Techniques – Pole Switching, V3F Drives Open and Closed loop	2
4.2	Permanent Synchronous Motor (Radial), Pumps – for hydraulic elevator, Regenerative Braking – Harmonics.	1
5	Door Controller and Elevator Control	
5.1	BLDC Motors and Commutation Principles	2
5.2	Call allocation – Group elevators, Elevator Position Control	1

Module No.	Topic	No. of Lectures
	System	
5.3	Elevator Door Control and Shaft learning mode.	1
6	Elevator control and Ride Analysis with Safety Standards	
6.1	Advance Door Opening, Emergency Rescue Drive, Service Mode	1
6.2	Operation, Elevator Standards on noise, jerk, and acceleration.	1
6.3	Ride Analysis: Elevator Ride Analysis with 3D Accelerometer.	1
Total		14 Hours

Course Designers:

- | | | |
|-----------------------|---|-------------------------|
| 1. Mr. S. Ananthkumar | - | s.ananthkumar@gmail.com |
| 2. Ms S. Siva Priya | - | siva2692@hotmail.com |
| 3. Mr M.A Ganesh | - | ganeshma2015@tce.edu |

Preamble

Today, Industries are increasingly demanding process automation in all sectors. Automation results into better quality, increased production and reduced costs. Machine tools and Robots are become fundamental components of any automated Manufacturing work cell. The controlling parameters like motion, Speed, Position and torque are paramount in raising productivity and quality and reducing energy and equipment costs in all industries. Electric drives share most of industrial machine control applications. The heart of the modern machine tool are the motion control elements, which includes a numerical controller and a number of servo drives. The servo drives which drives machine tools need to achieve a high precision and accuracy.

Prerequisite

- 14MT330-Sensors and PLC

Course Outcomes

On successful completion of the course, students will be able to

CO 1.	Explain about the product specifications, range, hardware / constructional details and features of the product.	Understand
CO 2.	Perform drive start-up and parameterize drive for different configurations including use of programmable digital and analog inputs and outputs.	Understand
CO 3.	Select a drive and develop a program for given motion control applications	Apply

Mapping with Programme Outcomes

Cos	PO1	PO2	PO3	PO4	PO5	PO6	PO7	PO8	PO9	PO10	PO11	PO12
CO1.	M	M	L	S	M	S	S	S	M	S	S	M
CO2.	M	M	L	S	M	S	S	M	M	M	M	M
CO3.	M	M	S	S	M	S	S	S	M	M	M	M

S- Strong; M-Medium; L-Low

Assessment Pattern

Bloom's Category	Continuous Assessment Test	Terminal Examination
Remember	20	20
Understand	40	40
Apply	40	40
Analyse	-	-
Evaluate	-	-
Create	-	-

Course Level Assessment Questions

Course Outcome 1 (CO1):

1. List the application of servo drive.
2. Write the important specifications of servo drive.
3. Describe the features of servo drive .
4. Draw the block diagram of the servo system.

Course Outcome 2(CO2):

1. Explain the hard ware components of servo drive.
2. Explain the software components of servo drive.
3. Describe the methods of configuring servo drive parameters

Course Outcome 3 (CO3):

1. Explain different methods of controlling servo drives.
2. Describe the method of configuring servo drive for machine tool applications.

Course Outcome 4 (CO4):

1. Select a drive and program servo drive using PLC for a robotic application with a payload of 10 Kg.
2. Develop servo drive program for driving axis motor of CNC turning Machine .
Develop a servo program to control 3 axis CNC Milling Machine.

Concept Map

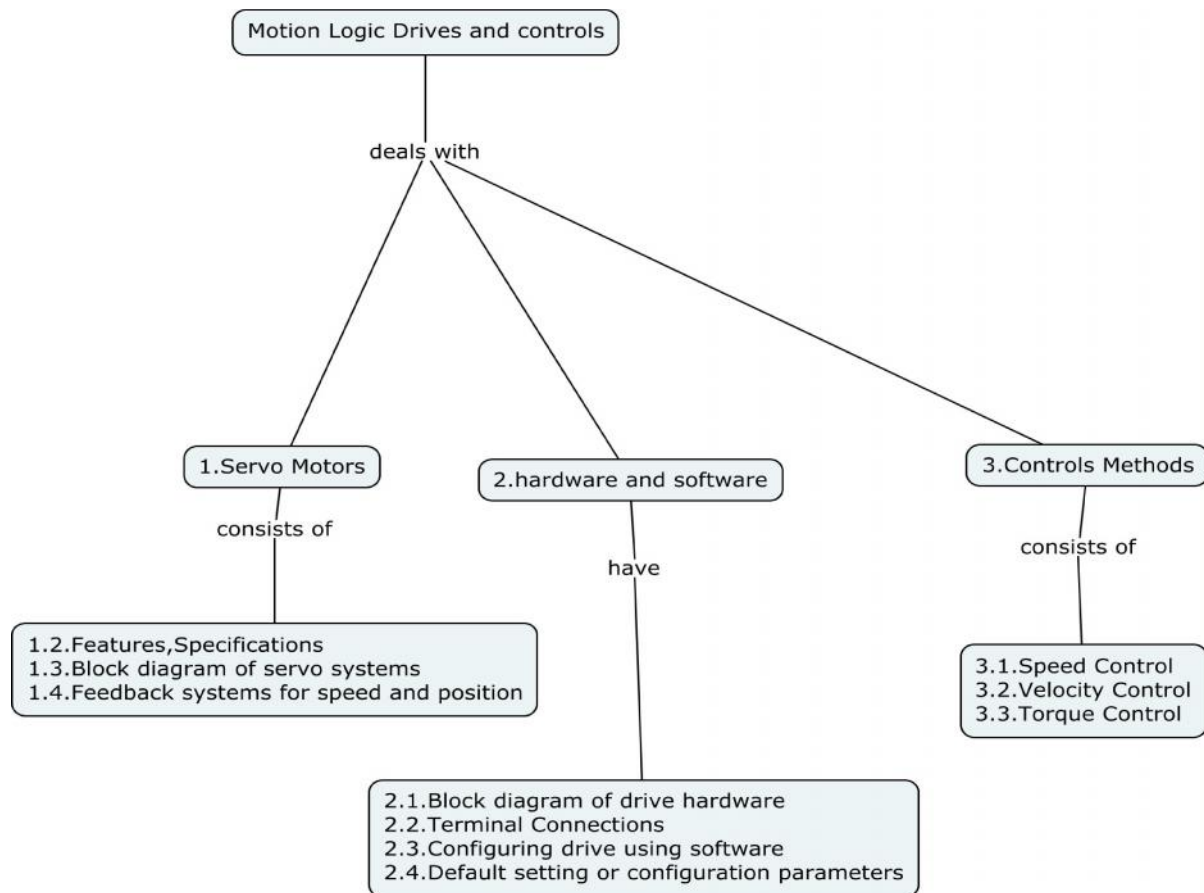

Syllabus

Basics of Servo motor-Features, types, Specifications - Block Diagram of a Servo System.

- Difference between Induction Motor & Servo Motor - Various feedback systems for Speed & Position feedback- Selection of servo motor

Hardware and Software components of Servo Drive-Block diagram of position controlled (Servo) drive- Hardware details of servo drive-Motor-Drive Connection details-Switch on sequence and signal Details-Configuring drive using software-Software features- Loading the default settings or default parameters of the drive- Start Up Axis Configuration & testing- Programming with LAD/FBD-Speed control using Digital and analog Signals-Positioning using Digital and analog signals- Creating Functions , Function Blocks & Libraries with ST.

Servo Drive Control methods- Motion control concept like Axis, Types of Axis, Types of Positioning, Homing- Comparison between Servo & other conventional methods of Speed Control of Motors—Running the motor in different operating modes-Velocity, Position, Torque control- Running the motor with different command signals-Analog ,Digital, bus interface-

Running the Motor in different operating modes using the PLC inside the Drive- Running the drives in Master/Slave Configuration.

Text Books

1. Ion Boldea, S.A Naser “**Electric Drives**” CRC Taylor & Francis group edition,2009
2. Austin hughes, “**Electric motors and Drives fundamentals, types, applications**” ,third edition elseveir,2006.
3. Indra Motion Logic Drives ,Indra works Software User Manual Bosch Rexroth.

Course Contents and Lecture Schedule

Module No.	Topic	No. of Lectures
1	Basics Of Servo Motors	
1.1	Servo Features, Types, Specifications, Selection	1
1.2	Block Diagram of servo system	
1.3	Difference between Induction Motor & Servo Motor	1
1.4	Various feedback systems for Speed & Position	1
2	Hardware and Software Components of Servo Drive	
2.1	Block diagram of position controlled Servo drive	1
2.2	Hardware details of servo drive	1
2.3	Motor-Drive Connection details	1
2.4	Switch on sequence and signal Details	1
2.5	Configuring drive using software-Software features	1
2.6	Loading the default settings or default parameters of the drive	1
3	Servo Drive Control Methods	
3.1	Start Up Axis Configuration & testing	1
3.2	Motion control concept like Axis, Types of Axis, Types of Positioning, Homing	1
3.3	Speed and Position control using Digital and analog Signals	1
3.4	Configuring servo drives for Motion control applications.	1
3.5	Running the motor in different operating modes-Velocity, Position, Torque control	1
3.6	Running the Motor in different operating modes using the PLC inside the Drive	1
3.7	Running the drives in Master/Slave Configuration.	1
Total		16 Hours

Course Designers:

- | | | |
|---------------------|---|------------------------|
| 1. Mr.Milind Tavree | - | milindtavree@bosch.com |
| 2. Mr H.Ramesh | - | rameshh@tce.edu |

Preamble

Hydraulics is applied in a wide range of Industries: From construction machinery, automobiles, and air planes (outdoor) to machine tools and Press machines (Indoor).Hydraulic systems are extremely important to the operation of heavy equipment. Hydraulic principles are used when designing steering systems , brake systems, power train systems and automatic transmissions. Hydraulics play a major role in mining, construction, agricultural and material handling equipments.

Prerequisite

- 14MT450 -Fluid Power Automation
-

Course Outcomes

On successful completion of the course, students will be able to

CO 1	Identify different components used in Mobile Hydraulics	Remember
CO 2	Explain control types in mobile machines	Understand
CO 3	Explain construction, functioning and maintenance of hydraulic units used in mobile systems.	Understand
CO4	Develop Circuits for Different types of mobile machines.	Apply

Mapping with Programme Outcomes

Cos	PO1	PO2	PO3	PO4	PO5	PO6	PO7	PO8	PO9	PO10	PO11	PO12
CO1	M	M	L	S	M	S	S	S	M	S	S	M
CO2	M	M	L	S	M	S	S	M	M	M	M	M
CO3	M	M	S	S	M	S	S	S	M	M	M	M
CO4	M	S	S	S	S	S	S	S	M	S	S	M

S- Strong; M-Medium; L-Low

Assessment Pattern

Bloom's Category	Continuous Assessment Test	Terminal Examination
Remember	20	20
Understand	40	40
Apply	40	40
Analyse	-	-
Evaluate	-	-
Create	-	-

Course Level Assessment Questions

Course Outcome 1 (CO1):

1. List the types of Hydraulic cylinders
2. Draw the symbol of throttle check valve.
3. List the types of Hydraulic Pumps used in Mobile applications.
4. List the types of hydraulic motors used in Mobile applications.

Course Outcome 2(CO2):

1. Explain throttle control used in Mobile vehicle.
2. Explain Load sensing Valve control.
3. Explain sandwich type mobile control valves
4. List the disadvantages of hydraulic drive.

Course Outcome 3 (CO3):

1. List the technical Specifications of the hydraulic Cylinder.
2. Explain the function of flow control valve.
3. Explain proportional and servo technology for mobile applications.

Course Outcome 4 (CO4):

1. Develop a Speed Control Circuit for Automobile
2. Develop a Pressure control circuit for Forklift
3. Describe the function of CAN bus in Mobile hydraulics

Concept Map

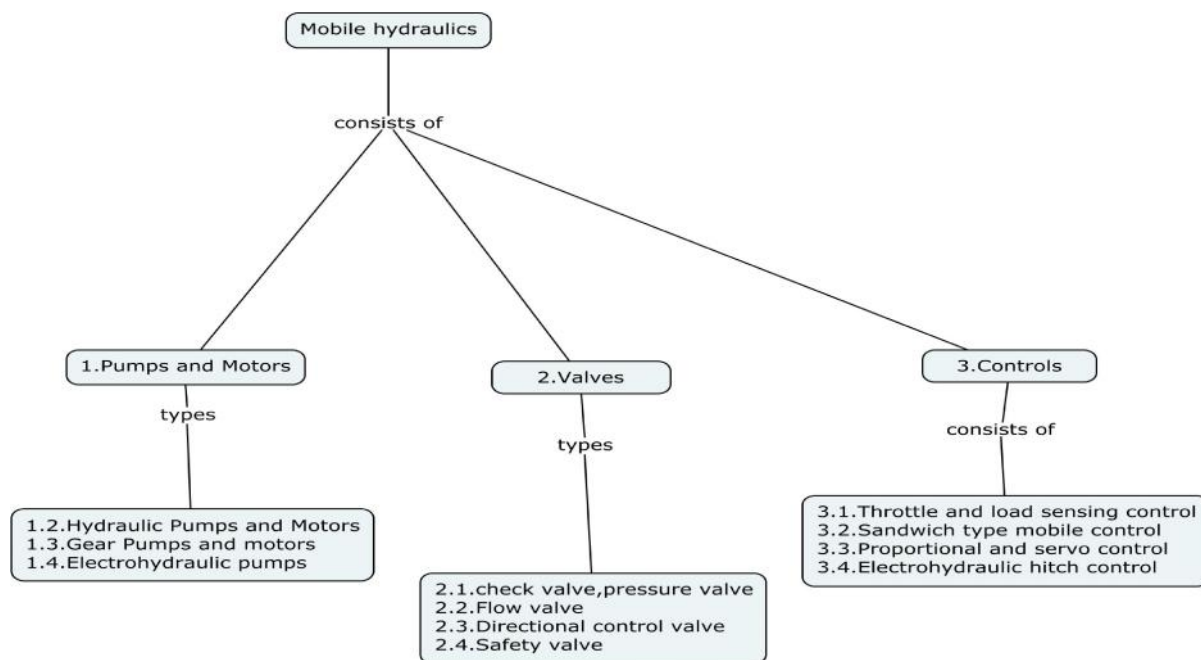

Syllabus

Pumps and Motors : Basics of mobile hydraulics – Hydraulics Pumps and Motors for mobile applications-Gear pumps and gear motors-Electro hydraulic pumps-Hydrostatic fan drives in vehicles.

Valves: Check valves, Pressure valves, Flow control valves, Directional Control valves, Safety valves.

Controls and Circuits of Mobile Hydraulics: Throttle control, Load Sensing Control, Sandwich type mobile control valves, Mobile Control blocks, Proportional and servo technology for mobile applications, Electro hydraulic hitch control for tractors, CAN bus in Mobile hydraulics, Various types of Mobile machines and its typical circuits.

Text Books

1. Hydraulics in Mobile Equipment, Text book from Bosch Rexroth Literature.
2. Compact Knowledge hydraulics -basic principles, Text book of Bosch Rexroth
3. Knowledge in detail hydraulics in tractors, Text book from bosch Rexroth

Course Contents and Lecture Schedule

Module No.	Topic	No. of Lectures
1	Pumps and Motors used in Mobile Hydraulics	
1.1	Basics of Mobile hydraulics	1
1.2	Hydraulic pumps and motors for Mobile Applications	
1.3	Gear Pumps and Gear Motors	1
1.4	Electro hydraulic pumps	1
1.5	Hydrostatic fan drives in Vehicles	1
2	Valves	
2.1	Check valves ,Pressure valves	1
2.2	Flow Control valves	1
2.3	Directional Control Valves	1
2.4	Safety Valves	1
3	Controls and circuits of Mobile hydraulics	
3.1	Throttle control, Load sensing control	1
3.2	Sandwich type mobile control valves, Mobile Control blocks	2
3.3	Proportional and servo technology for mobile applications	2
4.1	Electro hydraulic hitch control for tractors	1
4.2	CAN bus in Mobile hydraulics	1
4.3	Various types of Mobile machines and its typical circuits.	1
Total		16 Hours

Course Designers:

1. Mr.Bharath.T.S - bharath.t.s@bosch.com
2. Mr H.Ramesh - rameshh@tce.edu

14MT691

ROBOTICS LABORATORY

Category	L	T	P	Credit(s)
PC	0	0	2	1

Preamble

It provides in-depth knowledge on modelling of robots, simulating them in a particular environment and programming them to perform a particular task. This course is useful for those students interested in control engineering, robotics and systems engineering.

Prerequisite

- 14MT620 – Industrial Robotics

Course Outcomes

On the successful completion of the course, students will be able to

CO Number	Course Outcome Statement
CO1	To simulate and verify a particular environment of an industrial robot using MOTO SIM
CO2	Program and execute inspection application using robot
CO3	Program and execute assembly, deburring application using GP12 robot
CO4	Program and execute collaborative operation using GP12 and MH5LS robot
CO5	Program and analyse the kinematics of a mobile robot
CO6	Program the mobile robot for a particular application

Mapping with Programme Outcomes and Programme Specific Outcomes

Cos	PO1	PO2	PO3	PO4	PO5	PO6	PO7	PO8	PO9	PO10	PO11	PO12
CO1	S	M	S	S	S	M	S	-	S	M	L	M
CO2	S	M	S	S	S	M	-	-	S	M	L	M
CO3	S	M	S	S	S	M	-	-	S	M	L	M
CO4	S	S	S	S	S	M	-	-	S	M	L	S
CO5	S	M	S	S	S	M	-	-	S	M	L	M
CO6	S	M	S	S	S	M	-	-	S	M	L	M

S – Strong

M – Medium

L – Low

List of Experiments/Activities with CO Mapping

Ex.No	Experiments/Exercise	Hours
1	To simulate and evaluate the performance of the industrial robot using MOTO SIM software	2
2	To program and evaluate the inspection operation using MH5LS robot	2
3	To program and perform the Pick and place operation using GP12 robot	2
4	To program and perform the Palletizing operation using GP12 robot	2
5	To program and perform the Deburring operation using GP12 robot	2
6	To program and perform the Assembly operation using GP12 robot	2
7	To program and perform a collaborative operation using MH5LS and GP12 robot	2
8	To program and evaluate the differential drive kinematics of a wheeled robot using QBOT2	2
9	To program and evaluate the forward drive kinematics of a wheeled robot using QBOT2	2
10	To program and evaluate a sorting operation using QBOT2	2

11	To program and evaluate a surveillance operation using QBOT2	2
12	To program and evaluate Autonomous navigation operation using QBOT2	2
	Total	24

Course Designers:

Sl. No.	Name	E-mail Id
1	Prof M.A.Ganesh	ganeshma2015@tce.edu

REVISED CO - PO MAPPING**14MT210****ENGINEERING MATHEMATICS II**Category L T P Credit(s)
BS 2 2 0 3**Course Outcomes**

On the successful completion of the course, students will be able to

CO1	Solve linear and constant coefficient difference equations using Z-transforms	Apply
CO2	Apply the vector differential operators to represent the physical phenomena like gradient, directional derivative, curl, divergence and to verify vectors for irrotational and solenoidal.	Apply
CO3	Find work done by line integral of vector point function and inferring the relations among line integral, surface integral and volume integral using Green's, Stoke's and Gauss Divergence theorems.	Apply
CO4	Apply Laplace transform to solve the given ordinary differential equation and system of ODE	Apply
CO5	Construct an analytic function, when its real or imaginary part is known and discuss about the transformations of standard functions such as $\sin z$, z^2 , e^z and identify the singular points of a given complex function	Apply

Mapping with Programme Outcomes and Programme Specific Outcomes

Cos	PO1	PO2	PO3	PO4	PO5	PO6	PO7	PO8	PO9	PO10	PO11	PO12	PSO1	PSO2
CO1	S	M	L	-	L	L	L	L	M	M	L	S	S	M
CO2	S	M	L	-	L	L	L	L	M	M	L	S	M	L
CO3	S	M	L	-	L	L	L	L	M	M	L	S	-	-
CO4	S	M	L	-	L	L	L	L	M	M	L	S	L	M
CO5	S	M	L	-	L	L	L	L	M	M	L	S	S	S

S – Strong M – Medium L – Low

14MT220**FREE BODY MECHANICS**Category L T P Credit(s)
PC 2 2 0 3**Course Outcomes**

On the successful completion of the course, students will be able to

CO1	Enumerate the basic of concept of mechanics and fundamentals of friction	Remember
CO2	Solve problems in engineering systems using the concept of static equilibrium	Apply
CO3	Determine the centroid of a line, areas, and volumes, center of mass of body and moment of inertia of composite areas.	Apply
CO4	Solve problems involving frictional phenomena in machines	Apply
CO5	Solve problems involving kinematics and kinetics of particles in two- and three-dimensions	Apply
CO6	Solve problems involving kinematics and kinetics of rigid bodies in plane motion.	Apply
CO7	Solve problems using D'Alembertz principles.	Apply

Mapping with Programme Outcomes and Programme Specific Outcomes

Cos	PO1	PO2	PO3	PO4	PO5	PO6	PO7	PO8	PO9	PO10	PO11	PO12	PSO1	PSO2
CO1	L	-	-	-	-	-	-	-	-	-	M	-	L	M
CO2	S	M	L	-	-	-	-	-	L	-	M	-	L	M
CO3	S	M	L	-	-	-	-	-	L	-	M	-	L	-
CO4	S	M	L	-	-	-	-	-	L	-	M	-	L	-
CO5	S	M	L	-	-	-	-	-	L	-	M	-	M	M
CO6	S	M	L	-	-	-	-	-	L	-	M	-	M	-
CO7	S	M	L	-	-	-	-	-	L	-	M	-	-	L

S – Strong

M – Medium

L – Low

14MT230**ELECTRICAL MACHINES**

Category L T P Credit(s)

PC 3 0 0 3

Course Outcomes

On the successful completion of the course, students will be able to

CO1	Explain the various types of Machines, principle and operation.	Understand
CO2	Explain the Construction principle and control of different types of Machines.	Understand
CO3	Explain the characteristics, Application of different types of Machines.	Understand
CO4	Determine the EMF and Torque equation of different types of Machines to solve problems based on its application	Apply
CO5	Select the suitable machine & working principle for a given situation and application.	Apply

Mapping with Programme Outcomes and Programme Specific Outcomes

Cos	PO1	PO2	PO3	PO4	PO5	PO6	PO7	PO8	PO9	PO10	PO11	PO12	PSO1	PSO2
CO1	M	L	-	-	-	-	-	-	-	-	-	-	-	-
CO2	M	L	-	-	-	-	-	-	-	-	-	-	-	-
CO3	M	L	-	-	-	-	-	-	-	-	-	-	-	-
CO4	S	M	L	-	-	-	-	-	M	-	-	-	L	S
CO5	S	M	L	-	-	L	-	-	M	M	L	L	L	M

S – Strong

M – Medium

L – Low

14MT240

**MATERIALS FOR MECHANICAL AND
ELECTRONIC SYSTEMS**Category L T P Credit(s)
PC 3 0 0 3**Course Outcomes**

On the successful completion of the course, students will be able to

CO1	Compute the thermal and electrical and magnetic properties of different types of materials	Apply
CO2	Interpret the basic mechanical properties and illustrate the procedure for testing of materials	Apply
CO3	Compute the conductivity and bandgap of a given semiconductor for different carrier concentration and temperatures	Apply
CO4	Explain the properties, structures and characteristics of materials used in LED and solar cells	Understand
CO5	Explain the properties and application of new engineering materials like nano materials and shape memory alloys.	Understand

Mapping with Programme Outcomes and Programme Specific Outcomes

Cos	PO1	PO2	PO3	PO4	PO5	PO6	PO7	PO8	PO9	PO10	PO11	PO12	PSO1	PSO2
CO1	L	-	-	-	-	-	-	-	-	-	M	-	L	M
CO2	S	M	L	-	-	-	-	-	L	-	M	-	L	M
CO3	S	M	L	-	-	-	-	-	L	-	M	-	L	-
CO4	S	M	L	-	-	-	-	-	L	-	M	-	L	-
CO5	S	M	L	-	-	-	-	-	L	-	M	-	M	M

S – Strong

M – Medium

L – Low

14MT250

**ENVIRONMENTAL SCIENCE AND
ENGINEERING**Category L T P Credit(s)
HSS 3 0 0 3**Course Outcomes**

On the successful completion of the course, students will be able to

CO1	Comprehend the structure and function of the ecosystem	Understand
CO2	Account for ecological succession of ecosystem	Understand
CO3	Illustrate the features of biodiversity	Apply
CO4	Recall the uses of natural resource	Remember
CO5	Recommend the solution for reduce pollution from automobiles.	Apply
CO6	Relate the EURO and Bharat stage norms for pollutants	Understand
CO7	Identify the suitable disaster management for natural calamities	Apply
CO8	Conserve and follow the environmental ethics and Act	Understand

Mapping with Programme Outcomes and Programme Specific Outcomes

Cos	PO1	PO2	PO3	PO4	PO5	PO6	PO7	PO8	PO9	PO10	PO11	PO12	PSO1	PSO2
CO1	M	L	-	-	L	S	M	M	L	L	M	M	S	S
CO2	M	L	-	-	L	M	M	M	L	L	M	M	M	M
CO3	S	M	L	-	L	M	M	M	L	L	M	M	L	M
CO4	L	-	-	-	L	S	M	M	L	L	M	M	S	S
CO5	S	M	L	-	M	S	S	S	L	L	S	S	S	M
CO6	M	L	-	-	L	S	S	S	L	M	S	S	M	M
CO7	S	M	L	-	L	M	M	M	L	L	M	M	L	L
CO8	M	L	-	-	L	M	M	S	L	M	M	M	M	M

S – Strong

M – Medium

L – Low

14MT270 ANALOG AND DIGITAL DEVICES

Category L T P Credit(s)
PC 2 0 1 3

Course Outcomes

On the successful completion of the course, students will be able to

CO1	state the basic laws pertaining to the analog and digital system for Mechatronics application	Remember
CO2	Explain the components of analog and digital system and their functions	Understand
CO3	Select suitable analog design Techniques for mechatronic system to a given real time applications such as robot, automobile and bio-medical equipment's	Apply
CO4	Select suitable type of digital system and design Techniques for mechatronic system to a given real time applications such as robot, automobile and bio-medical equipment's	Apply

Mapping with Programme Outcomes and Programme Specific Outcomes

Cos	PO1	PO2	PO3	PO4	PO5	PO6	PO7	PO8	PO9	PO10	PO11	PO12	PSO1	PSO2
CO1	L	-	-	-	-	-	-	-	S	S	-	-	S	S
CO2	M	L	M	-	-	-	-	-	S	S	-	-	S	S
CO3	S	M	L	-	-	-	-	-	S	S	-	-	M	M
CO4	S	M	L	-	-	-	-	-	S	S	-	-	M	M

S – Strong M – Medium L – Low

14MT290**WORK SHOP**

Category L T P Credit(s)
PC 0 0 2 1

Course Outcomes

On the successful completion of the course, students will be able to

CO1	Construct the different laminas of regular shapes.	Apply
CO2	Prepare the different types of fitting using MS plate.	Apply
CO3	Create simple sheet metal components.	Apply
CO4	Prepare the different types of joints using wooden material.	Apply

Mapping with Programme Outcomes and Programme Specific Outcomes

Cos	PO1	PO2	PO3	PO4	PO5	PO6	PO7	PO8	PO9	PO10	PO11	PO12	PSO1	PSO2
CO1	S	M	L	-	L	L	L	L	L	L	L	L	S	M
CO2	S	M	L	-	L	L	L	L	L	L	L	L	-	-
CO3	S	M	L	-	L	L	L	L	L	L	L	L	S	L
CO4	S	M	L	-	L	L	L	L	L	L	L	L	M	S

S – Strong M – Medium L – Low

14MT310

**FOURIER ANALYSIS AND PARTIAL
DIFFERENTIAL EQUATIONS**Category L T P Credit(s)
BS 2 2 0 3**Course Outcomes**

On the successful completion of the course, students will be able to

CO1	Obtain the periodic functions arising in the study of engineering problems in terms of Sines and Cosines or complex exponentials by using Fourier series, Discrete Fourier series.	Apply
CO2	Obtain the piece wise continuously differentiable and integrable functions arising in the study of engineering problems in terms of integral involving Sines and Cosines or complex exponentials by using Fourier transform, Sine and Cosine Fourier transform, discrete Fourier transform and Fast Fourier transform.	Apply
CO3	Formulate and Solve Partial Differential Equations (linear, nonlinear, homogeneous and non-homogeneous) by various methods.	Apply
CO4	Solve the boundary value problems arising in engineering problems involving one dimensional vibration problems, one dimensional heat flow problems by Fourier series.	Apply
CO5	Solve the boundary value problems arising in engineering problems represented by two dimensional heat flow problems by Fourier series.	Apply

Mapping with Programme Outcomes and Programme Specific Outcomes

Cos	PO1	PO2	PO3	PO4	PO5	PO6	PO7	PO8	PO9	PO10	PO11	PO12	PSO1	PSO2
CO1	S	M	L	-	-	-	-	-	-	M	-	M	M	M
CO2	S	M	L	-	-	-	-	-	-	M	-	M	M	M
CO3	S	M	L	-	-	-	-	-	-	M	-	M		
CO4	S	M	L	-	-	-	-	-	-	M	-	M	L	L
CO5	S	M	L	-	-	-	-	-	-	M	-	M		

S – Strong

M – Medium

L – Low

14MT320	KINEMATICS AND DYNAMICS OF MACHINERY	Category	L	T	P	Credit(s)
		PC	2	2	0	3

Course Outcomes

On the successful completion of the course, students will be able to

CO1	Define the working principles of various mechanism and inversions	Remember
CO2	Determine velocity and acceleration for simple mechanism	Apply
CO3	Construct the turning moment diagram for flywheel	Apply
CO4	Develop the cam profile for various types of follower	Apply
CO5	Identify the speed and no of tooth of gear and gear trains	Apply
CO6	Construct the governing differential equations and its solution for a vibrating system	Apply

Mapping with Programme Outcomes and Programme Specific Outcomes

Cos	PO1	PO2	PO3	PO4	PO5	PO6	PO7	PO8	PO9	PO10	PO11	PO12	PSO1	PSO2
CO1	L	L	-	-	-	-	-	-	-	-	-	-	M	S
CO2	S	M	L	-	-	-	-	-	-	-	-	-	M	M
CO3	S	M	L	-	-	-	-	-	-	-	-	-	M	M
CO4	S	M	L	-	-	-	-	-	-	-	-	-	-	-
CO5	S	M	L	-	-	-	-	-	-	-	-	-	-	L
CO6	S	M	L	-	-	-	-	-	-	-	-	-	L	-

S – Strong M – Medium L – Low

14MT330	SENSORS AND PLC	Category	L	T	P	Credit(s)
		PC	3	0	0	3

Course Outcomes

On the successful completion of the course, students will be able to

CO1	Explain the function of sensor system and its method of measurements	Understand
CO2	Select a suitable sensor and implement it for given application	Apply
CO3	Exemplify the functionality along with PLC components	Understand
CO4	Develop PLC program for an application	Apply

Mapping with Programme Outcomes and Programme Specific Outcomes

Cos	PO1	PO2	PO3	PO4	PO5	PO6	PO7	PO8	PO9	PO10	PO11	PO12	PSO1	PSO2
CO1	M	L	-	-	S	-	-	-	-	S	L	M	S	S
CO2	S	M	L	L	S	S	S	S	S	S	S	S	M	M
CO3	M	L	-	-	S	-	-	-	-	S	L	L	L	-
CO4	S	M	L	L	S	S	S	S	S	S	S	S	-	L

S – Strong M – Medium L – Low

14MT340**THERMAL ENGINEERING AND FLUID
MECHANICS**Category L T P Credit(s)
PC 2 2 0 3**Course Outcomes**

On the successful completion of the course, students will be able to

CO1	Determine the properties and energy interaction in the closed and open system.	Apply
CO2	Determine the efficiency of heat engine and COP of heat pump and refrigerator.	Apply
CO3	Determine the performance parameters of an internal combustion engine and air compressor.	Apply
CO4	Determine the properties of fluids.	Apply
CO5	Apply the kinematic and dynamic concepts to fluids related to the conservation principles of mass and energy.	Apply

Mapping with Programme Outcomes and Programme Specific Outcomes

Cos	PO1	PO2	PO3	PO4	PO5	PO6	PO7	PO8	PO9	PO10	PO11	PO12	PSO1	PSO2
CO1	S	M	L	-	M	-	L	-	L	-	L	M	S	M
CO2	S	M	L	-	M	-	L	-	L	-	L	M	M	-
CO3	S	M	L	-	M	-	L	-	L	-	L	M	-	M
CO4	S	M	L	-	M	-	L	-	L	-	L	M	S	L
CO5	S	M	L	-	M	-	L	-	L	-	L	M	M	L

S – Strong

M – Medium

L – Low

14MT350**MANUFACTURING PROCESSES**Category L T P Credit(s)
PC 3 0 0 3**Course Outcomes**

On the successful completion of the course, students will be able to

CO1	Explain the principle, types and various operations of metal casting, metal forming, metal joining and machining processes.	Understand
CO2	Explain the process capabilities of various metal casting, metal forming, metal joining and machining processes.	Understand
CO3	Select the suitable metal casting and forming processes for a given product or component.	Apply
CO4	Suggest the suitable joining methods for fabrication / assembly of product.	Apply
CO5	Select a suitable process for machining of a given part.	Apply

Mapping with Programme Outcomes and Programme Specific Outcomes

Cos	PO1	PO2	PO3	PO4	PO5	PO6	PO7	PO8	PO9	PO10	PO11	PO12	PSO1	PSO2
CO1	M	L	-	-	-	-	-	-	-	-	-	-	S	S
CO2	M	L	-	-	-	-	-	-	-	-	-	-	M	-
CO3	S	M	L	-	-	-	-	-	-	-	-	-	L	L
CO4	S	M	L	-	-	-	-	-	-	-	-	-	S	-
CO5	S	M	L	-	-	-	M	-	-	-	M	-	S	M

S – Strong

M – Medium

L – Low

14MT370	PROBLEM SOLVING USING COMPUTER	Category	L	T	P	Credit(s)
		PC	2	0	2	3

Course Outcomes

On the successful completion of the course, students will be able to

CO1	Construct algorithms for solving simple mathematical and engineering problems using appropriate control structures like repetition and selection.	Apply
CO2	Build flow charts for modelling solutions to solve numerical and engineering problems.	Apply
CO3	Construct solutions for problems related to merging, searching, sorting and string manipulation using either iteration or recursion as applicable.	Apply
CO4	Construct solutions involving structures to store, manipulate and retrieve records of data.	Apply

Mapping with Programme Outcomes and Programme Specific Outcomes

Cos	PO1	PO2	PO3	PO4	PO5	PO6	PO7	PO8	PO9	PO10	PO11	PO12	PSO1	PSO2
CO1	S	M	L	-	-	-	-	-	-	-	-	M	L	L
CO2	S	M	L	-	-	-	-	-	-	-	-	M	L	L
CO3	S	M	L	-	S	-	-	-	M	M	-	M	S	S
CO4	S	M	L	-	S	-	-	-	M	M	-	M	S	S

S – Strong M – Medium L – Low

14MT390	MANUFACTURING PROCESSES LAB	Category	L	T	P	Credit(s)
		PC	0	0	2	1

Course Outcomes

On the successful completion of the course, students will be able to

CO1	Construct the mould using single and split piece pattern and prepare for casting.	Apply
CO2	Perform Arc/MIG/Spot welding and Brazing /Soldering.	Apply
CO3	Perform various operations in lathe, milling, drilling and grinding machines.	Apply

Mapping with Programme Outcomes and Programme Specific Outcomes

Cos	PO1	PO2	PO3	PO4	PO5	PO6	PO7	PO8	PO9	PO10	PO11	PO12	PSO1	PSO2
CO1	S	M	L	L	L	L	L	L	L	L	L	L	S	M
CO2	S	M	L	L	L	L	L	L	L	L	L	L	S	M
CO3	S	M	L	L	L	L	L	L	L	L	L	L	-	-

S – Strong M – Medium L – Low

14MT410	LINEAR ALGEBRA AND NUMERICAL METHODS	Category	L	T	P	Credit(s)
		BS	2	2	0	3

Course Outcomes

On the successful completion of the course, students will be able to

CO1	Solve linear system of equations and to apply it in technical situations, and to represent linear transformations in terms of matrices also to factorise matrices.	Apply
CO2	Understand the concept of vector space, Basis, dimension and rank of vector space, null space, column space, linear transformation.	Understand
CO3	Calculate dimension, rank of a vector space, also to apply Eigen values, Eigen vectors in linear transformation and discrete evaluation of dynamic systems.	Apply
CO4	Orthogonalize a basis and to solve system of equations $AX = b$ using least square method and to factorise matrices using singular value decomposition also to apply inner product space to evaluate weighted least square.	Apply
CO5	Solve algebraic and transcendental equations, linear simultaneous equation and ordinary differential equations, numerically.	Apply

Mapping with Programme Outcomes and Programme Specific Outcomes

Cos	PO1	PO2	PO3	PO4	PO5	PO6	PO7	PO8	PO9	PO10	PO11	PO12	PSO1	PSO2
CO1	S	M	L	-	-	-	-	-	-	-	M	S	S	S
CO2	M	L	-	-	-	-	-	-	-	-	M	S	M	M
CO3	S	M	L	-	-	-	-	-	-	-	M	S	S	S
CO4	S	M	L	-	-	-	-	-	-	-	M	S	M	-
CO5	S	M	L	-	-	-	-	-	-	-	M	S	-	M

S – Strong

M – Medium

L – Low

14MT420	ENGINEERING DESIGN	Category	L	T	P	Credit(s)
		PC	1	0	4	3

Course Outcomes

On the successful completion of the course, students will be able to

CO1	Explain engineering and the qualities required in an engineering solution and in an engineer	Understand
CO2	Identify the need and define the problem statement	Apply
CO3	Apply engineering design process for the identified problem	Apply
CO4	Develop design specifications for the identified problem	Analyze
CO5	Develop working structure and concepts for the identified problem	Analyze
CO6	Provide embodiment and detail design for the identified problem	Analyze

Mapping with Programme Outcomes and Programme Specific Outcomes

Cos	PO1	PO2	PO3	PO4	PO5	PO6	PO7	PO8	PO9	PO10	PO11	PO12	PSO1	PSO2
CO1	M	L	L	-	-	S	M	S	-	-	-	S	S	M
CO2	S	M	L	-	-	S	M	S	M	M	-	S	S	M
CO3	S	M	L	-	L	S	M	S	M	M	L	S	S	M
CO4	S	S	M	L	M	M	M	S	S	M	L	S	S	M
CO5	S	S	M	L	M	-	S	S	S	M	L	S	S	M
CO6	S	S	M	L	M	S	S	S	S	S	M	S	S	M

S – Strong

M – Medium

L – Low

14MT430 ANALOG AND DIGITAL CIRCUITS DESIGN Category L T P Credit(s)
PC 3 0 0 3

Course Outcomes

On the successful completion of the course, students will be able to

CO1	Design feedback circuits and applications	Apply
CO2	Design op-amp and its applications	Apply
CO3	Design filters and controller circuits	Apply
CO4	Design synchronous and asynchronous sequential circuits	Apply
CO5	Design of Combinational and sequential circuits using VHDL	Apply

Mapping with Programme Outcomes and Programme Specific Outcomes

Cos	PO1	PO2	PO3	PO4	PO5	PO6	PO7	PO8	PO9	PO10	PO11	PO12	PSO1	PSO2
CO1	S	M	L	-	M	L	-	-	-	S	M	M	S	S
CO2	S	M	L	-	M	L	-	-	-	S	M	M	M	M
CO3	S	M	L	L	M	L	-	-	-	S	M	M	M	-
CO4	S	M	L	-	M	L	-	-	-	S	M	M	-	M
CO5	S	M	L	L	M	L	-	-	-	S	M	M	M	-

S – Strong M – Medium L – Low

14MT440 METROLOGY AND MEASUREMENTS Category L T P Credit(s)
PC 3 0 0 3

Course Outcomes

On the successful completion of the course, students will be able to

CO1	Explain the concepts and usage methods of measuring Instruments, gauges and measuring machines.	Understand
CO2	Choose appropriate Measuring system for the measurement of different industrial applications.	Apply
CO3	Select appropriate instruments/gauges to measure/inspect for different component.	Apply
CO4	Illustrate suitable measurement system along with its acquisition system for measuring dynamic variables in different industrial application.	Apply

Mapping with Programme Outcomes and Programme Specific Outcomes

Cos	PO1	PO2	PO3	PO4	PO5	PO6	PO7	PO8	PO9	PO10	PO11	PO12	PSO1	PSO2
CO1	M	L	-	-	-	-	-	-	-	M	-	-	S	L
CO2	S	M	L	-	-	-	-	-	M	-	-	L	M	M
CO3	S	M	L	-	-	-	-	-	-	M	-	-	M	M
CO4	S	M	L	-	M	L	-	-	M	-	-	M	M	S

S – Strong M – Medium L – Low

14MT450 FLUID POWER AUTOMATION

Category	L	T	P	Credit(s)
PC	3	0	0	3

Course Outcomes

On the successful completion of the course, students will be able to

CO1	Classify the properties of pneumatic and hydraulic systems and their applications	Understand
CO2	Classify and select the pumps and motors for the required applications.	Understand
CO3	Design the fluid systems with speed, pressure and direction control	Apply
CO4	Design the hydraulic and pneumatic circuits for the given application.	Apply

Mapping with Programme Outcomes and Programme Specific Outcomes

Cos	PO1	PO2	PO3	PO4	PO5	PO6	PO7	PO8	PO9	PO10	PO11	PO12	PSO1	PSO2
CO1	M	L	-	-	-	-	-	-	-	-	-	-	-	-
CO2	M	L	-	-	-	-	-	-	-	-	-	-	-	-
CO3	S	M	L	-	M	-	-	-	M	M	L	L	M	M
CO4	S	M	L	-	M	-	-	-	M	M	L	L	M	M

S – Strong M – Medium L – Low

14MT470 PROFESSIONAL COMMUNICATION

Category	L	T	P	Credit(s)
HSS	1	0	2	2

Course Outcomes

On the successful completion of the course, students will be able to

CO1	Plan, organise, write, and present project reports, and technical papers in the frame of the scientific method	Apply
CO2	Establish themselves through communication skills in corporate environment.	Apply
CO3	Solve verbal aptitude questions related to placement and higher studies.	Apply
CO4	Apply their interpersonal skills in technical, professional and social contexts.	Apply

Mapping with Programme Outcomes and Programme Specific Outcomes

Cos	PO1	PO2	PO3	PO4	PO5	PO6	PO7	PO8	PO9	PO10	PO11	PO12	PSO1	PSO2
CO1	-	-	-	-	-	-	-	-	M	M	-	-	-	-
CO2	-	-	-	-	-	-	-	-	M	M	-	-	M	M
CO3	-	-	-	-	-	-	-	-	M	M	-	-	-	-
CO4	-	-	-	-	-	-	-	-	M	M	-	-	-	-

S – Strong M – Medium L – Low

14MT480**AUTOMATION LAB**

Category	L	T	P	Credit(s)
PC	0	0	2	1

Course Outcomes

On the successful completion of the course, students will be able to

CO1	Design and Simulate Pneumatic and hydraulic circuits using software	Apply
CO2	Design and implement Pneumatic circuits using hardware	Apply
CO3	Design and implement electro pneumatic and PLC interfacing circuits	Apply
CO4	Develop PLC program for Motor control applications	Apply

Mapping with Programme Outcomes and Programme Specific Outcomes

Cos	PO1	PO2	PO3	PO4	PO5	PO6	PO7	PO8	PO9	PO10	PO11	PO12	PSO1	PSO2
CO1	S	M	L	-	S	L	M	M	S	S	M	S	S	S
CO2	S	M	L	-	S	M	M	M	S	S	M	S	M	M
CO3	S	M	L	-	S	L	M	M	S	S	S	S	-	-
CO4	S	M	L	-	S	M	M	M	S	S	S	S	M	M

S – Strong M – Medium L – Low

14MT490 METROLOGY AND MEASUREMENTS LAB

Category	L	T	P	Credit(s)
PC	0	0	2	1

Course Outcomes

On the successful completion of the course, students will be able to

CO1	Measure Linear, angular, thread elements, 2D & 3D profiles, surface roughness, flatness and straightness.	Apply
CO2	Check and calibrate different dimensions for given components.	Apply
CO3	Measure and Verify displacement, force, level, torque, strain, speed temperature.	Apply

Mapping with Programme Outcomes and Programme Specific Outcomes

Cos	PO1	PO2	PO3	PO4	PO5	PO6	PO7	PO8	PO9	PO10	PO11	PO12	PSO1	PSO2
CO1	S	M	L	-	M	L	-	-	S	M	L	L	L	L
CO2	S	M	L	-	M	L	-	-	S	M	L	L	M	M
CO3	S	M	L	-	M	L	-	-	S	M	L	L	S	M

S – Strong M – Medium L – Low

14MT4C1**CAPSTONE COURSE – I**

Category	L	T	P	Credit(s)
PC	0	0	4	2

Course Outcomes

On the successful completion of the course, students will be able to

CO1	Explain the basic concepts of core engineering courses in the programme	Understand
CO2	Explain the importance of the mathematics and science courses in the programme and its correlation with the core engineering courses	Understand
CO3	Solve basic problems in core engineering courses of the programme	Apply
CO4	Solve complex problems by applying the concepts of core engineering, mathematics and science courses	Apply
CO5	Analyze complex problems in core engineering courses of the programme	Analyze

Mapping with Programme Outcomes and Programme Specific Outcomes

Cos	PO1	PO2	PO3	PO4	PO5	PO6	PO7	PO8	PO9	PO10	PO11	PO12	PSO1	PSO2
CO1	M	L	-	-	-	-	-	-	-	-	-	L	L	L
CO2	M	L	-	-	-	-	-	-	-	-	-	L	L	-
CO3	S	M	L	-	L	-	-	-	M	-	-	L	M	M
CO4	S	M	L	-	M	-	-	-	M	-	-	L	M	L
CO5	S	S	M	L	S	-	-	-	M	-	-	L	S	M

S – Strong M – Medium L – Low

14MT510**OPTIMIZATION TECHNIQUES**

Category	L	T	P	Credit(s)
BS	2	2	0	3

Course Outcomes

On the successful completion of the course, students will be able to

CO1	Formulate mathematical models of Linear Programming (LP), Integer Programming (IP), Dynamic Programming (DP), Non-linear Programming (NLPP) problems	Apply
CO2	Solve Linear Programming Problems (LPP) by graphical, simplex and dual-simplex methods	Apply
CO3	Solve Integer Programming Problems (IPP) using branch and bound, and cutting plane method	Apply
CO4	Solve deterministic Dynamic Programming Problems using tabular approach	Apply
CO5	Solve unconstrained and constrained Non-Linear Programming Problems (NLPP) using appropriate techniques.	Apply
CO6	Explain the concept and working of emerging intelligent search techniques such as Genetic Algorithm (GA), Ant Colony Optimization (ACO), Particle Swarm Optimization (PSO), Simulated Annealing Algorithm (SAA) and Tabu Search (TS).	Understand

Mapping with Programme Outcomes and Programme Specific Outcomes

Cos	PO1	PO2	PO3	PO4	PO5	PO6	PO7	PO8	PO9	PO10	PO11	PO12	PSO1	PSO2
CO1	S	M	L	-	-	-	-	-	M	-	-	S	S	S
CO2	S	M	L	-	-	-	-	-	M	-	-	S	M	M
CO3	S	M	L	-	-	-	-	-	M	-	-	S	S	M
CO4	S	M	L	-	-	-	-	-	M	-	-	S	M	-
CO5	S	M	L	-	-	-	-	-	M	-	-	S	-	S
CO6	M	L	-	-	-	-	-	-	M	-	-	S	M	L

S – Strong

M – Medium

L – Low

14MT520**CONTROL SYSTEM**

Category L T P Credit(s)

PC 3 0 0 3

Course Outcomes

On the successful completion of the course, students will be able to

CO1	Develop transfer function of a described physical system	Apply
CO2	System Analysis based on time and frequency domain	Apply
CO3	Design compensator: Lead, Lag and Lead-Lag	Apply
CO4	Able to calculate the stability of discrete systems	Understand
CO5	Implement Digital PID Controller	Apply

Mapping with Programme Outcomes and Programme Specific Outcomes

Cos	PO1	PO2	PO3	PO4	PO5	PO6	PO7	PO8	PO9	PO10	PO11	PO12	PSO1	PSO2
CO1	S	M	-	L	S	-	-	-	S	S	L	S	M	M
CO2	S	M	-	L	S	-	-	-	S	S	L	L	M	M
CO3	S	M	-	L	S	-	-	-	S	S	L	-	M	M
CO4	S	M	-	L	S	-	-	-	S	S	L	L	M	M
CO5	S	M	-	L	S	-	-	-	S	S	L	L	M	M

S – Strong

M – Medium

L – Low

14MT530**POWER ELECTRONICS AND DRIVES**

Category L T P Credit(s)

PC 3 0 0 3

Course Outcomes

On the successful completion of the course, students will be able to

CO1	Explain the operation, characteristics and performance parameters of controlled converters.	Understand
CO2	Explain the working principle of pulse width modulated inverters.	Understand
CO3	Select a suitable power drive for a given application.	Apply
CO4	Choose appropriate converter technique to control electric drive for a given application.	Apply

Mapping with Programme Outcomes and Programme Specific Outcomes

Cos	PO1	PO2	PO3	PO4	PO5	PO6	PO7	PO8	PO9	PO10	PO11	PO12	PSO1	PSO2
CO1	M	L	-	-	-	-	-	-	-	-	-	-	-	-
CO2	M	L	-	-	-	-	-	-	-	-	-	-	-	-
CO3	S	M	L	-	-	-	-	-	M	-	-	-	M	M
CO4	S	M	L	-	M	L	-	-	M	L	-	L	M	M

S – Strong

M – Medium

L – Low

14MT540**CNC TECHNOLOGY**

Category	L	T	P	Credit(s)
PC	3	0	0	3

Course Outcomes

On the successful completion of the course, students will be able to

CO1	Explain the evolution and importance of CNC technology in manufacturing industry.	Understand
CO2	Describe the construction features and specification of various mechanical components used in a CNC system.	Understand
CO3	Select suitable drives and sensors for a CNC system for a specific application.	Apply
CO4	Develop CNC part program for basic turning and milling operations as per product geometry.	Apply
CO5	Suggest methodologies for CNC system maintenance and troubleshooting.	Apply

Mapping with Programme Outcomes and Programme Specific Outcomes

Cos	PO1	PO2	PO3	PO4	PO5	PO6	PO7	PO8	PO9	PO10	PO11	PO12	PSO1	PSO2
CO1	M	L	-	-	-	-	-	-	-	-	-	-	-	-
CO2	M	L	-	-	-	-	-	-	-	-	-	-	-	-
CO3	S	M	L	-	-	-	-	-	-	-	-	-	M	M
CO4	S	M	L	-	S	-	-	-	M	L	L	L	L	L
CO5	S	M	L	-	S	-	-	-	M	L	L	L	L	L

S – Strong M – Medium L – Low

14MT570**MICROCONTROLLER**

Category	L	T	P	Credit(s)
PC	2	0	2	3

Course Outcomes

On the successful completion of the course, students will be able to

CO1	Explain the architecture and its functional blocks of microcontroller	Understand
CO2	Develop ASM and C program using internal and external peripherals	Apply
CO3	Illustrate ADC, DAC and Sensor interfacing	Understand
CO4	Design a microcontroller-based system	Apply

Mapping with Programme Outcomes and Programme Specific Outcomes

Cos	PO1	PO2	PO3	PO4	PO5	PO6	PO7	PO8	PO9	PO10	PO11	PO12	PSO1	PSO2
CO1	L	-	-	-	-	L	-	-	-	-	L	M	S	S
CO2	S	L	-	-	-	-	-	L	-	M	L	-	M	M
CO3	L	-	-	M	-	-	-	L	-	-	-	-	-	-
CO4	S	L	-	-	-	L	-	-	L	-	-	M	M	M

S – Strong M – Medium L – Low

14MT580**CAD/CAM LABORATORY**

Category	L	T	P	Credit(s)
PC	0	0	2	1

Course Outcomes

On the successful completion of the course, students will be able to

CO1	Develop and manipulate CAD model/features for the given part /assembly drawing using operations such as extrusion, revolve, pattern hole, chamfer and rib	Apply
CO2	write/generate CNC part programming for given part drawing for performing operations in a CNC Lathe such as plain, stepped, thread and taper turning, and facing /Vertical milling machine such as profiling, pocketing and drilling and to simulate tool path for the machining.	Apply

Mapping with Programme Outcomes and Programme Specific Outcomes

Cos	PO1	PO2	PO3	PO4	PO5	PO6	PO7	PO8	PO9	PO10	PO11	PO12	PSO1	PSO2
CO1	S	M	L	-	S	-	-	-	-	M	M	-	M	S
CO2	S	M	L	-	S	-	-	-	-	M	M	-	M	M

S – Strong

M – Medium

L – Low

14MT590**ANALOG AND DIGITAL CIRCUIT DESIGN
LAB**

Category	L	T	P	Credit(s)
PC	0	0	2	1

Course Outcomes

On the successful completion of the course, students will be able to

CO1	Design and implement of basic OPAMP and IC555 circuits	Apply
CO2	Design and implement of various Analog system using Opamp	Apply
CO3	Design and Develop combinational circuits using digital design	Apply
CO4	Design and Develop sequential circuits using digital design	Apply

Mapping with Programme Outcomes and Programme Specific Outcomes

Cos	PO1	PO2	PO3	PO4	PO5	PO6	PO7	PO8	PO9	PO10	PO11	PO12	PSO1	PSO2
CO1	S	M	L		S	M	M	M	S	-	M	-	S	M
CO2	S	M	L		S	M	M	M	-	S	M	-	L	M
CO3	S	M	L		S	L	M	M	S	S	S	S	M	
CO4	S	M	L		S	M	M	M	-	-	S	S	M	L

S – Strong

M – Medium

L – Low

14MT610 ACCOUNTING AND FINANCE

Category L T P Credit(s)
HSS 3 0 0 3

Course Outcomes

On the successful completion of the course, students will be able to

CO1	Prepare financial statements and analyse them with common size statements, comparative statements and trend percentage methods	Apply
CO2	Prepare cost sheet.	Apply
CO3	Apportionment of overheads to production and service departments, service department overheads to production departments and Allocation of overheads based on the activities performed.	Apply
CO4	Prepare various functional budgets and cash budget and Calculation of material, labour and overhead cost variance and to identify the reasons for the variances.	Apply
CO5	Evaluate the probability of capital budgeting decisions by using pay back, accounting rate of return, net present value and internal rate of return methods and estimation of working capital management.	Apply

Mapping with Programme Outcomes and Programme Specific Outcomes

Cos	PO1	PO2	PO3	PO4	PO5	PO6	PO7	PO8	PO9	PO10	PO11	PO12	PSO1	PSO2
CO1	S	M	L	-	-	-	-	-	-	-	S	-	-	-
CO2	S	M	L	-	-	-	-	-	-	-	S	-	-	-
CO3	S	M	L	-	-	-	-	-	-	-	S	-	-	-
CO4	S	M	L	-	-	-	-	-	M	-	S	L	-	-
CO5	S	M	L	-	S	-	-	-	-	-	S	L	-	-

S – Strong M – Medium L – Low

14MT620 INDUSTRIAL ROBOTICS

Category L T P Credit(s)
PC 3 0 0 3

Course Outcomes

On the successful completion of the course, students will be able to

CO1	Describe the working of the subsystems of robotic manipulator and mobile robot	Understand
CO2	Develop the forward kinematic model of multi-degree of freedom (DOF) manipulator (for determining the position of end-effectors with respect to base) and inverse kinematic model (two degrees of freedom robot arm and wheeled robot) and dynamic model of two degrees of freedom robot arm	Apply
CO3	Develop a cubic polynomial trajectory in joint space with given kinematic constraints of multi-degree of freedom (DOF) manipulator	Apply
CO4	Explain various types of control schemes, sensors and interfaces used in the operation of robot/ with the robot controller	Understand

Mapping with Programme Outcomes and Programme Specific Outcomes

Cos	PO1	PO2	PO3	PO4	PO5	PO6	PO7	PO8	PO9	PO10	PO11	PO12	PSO1	PSO2
CO1	M	L	-	-	-	-	-	-	-	-	-	-	-	-
CO2	S	M	L	L	S	-	-	-	M	M	-	M	M	S
CO3	S	M	L	L	S	-	-	-	M	M	-	M	M	M
CO4	M	L	-	-	-	-	-	-	-	-	-	M	-	-

S – Strong M – Medium L – Low

14MT630 MECHATRONICS SYSTEM DESIGN

Category	L	T	P	Credit(s)
PC	3	0	0	3

Course Outcomes

On the successful completion of the course, students will be able to

CO1	Discuss about modelling of Mechatronic System	Understand
CO2	Explain the design process involved in mechatronics	Understand
CO3	Select the sensor and Actuator for a Mechatronic application	Apply
CO4	Develop a Mechatronic product for the given problem	Apply

Mapping with Programme Outcomes and Programme Specific Outcomes

Cos	PO1	PO2	PO3	PO4	PO5	PO6	PO7	PO8	PO9	PO10	PO11	PO12	PSO1	PSO2
CO1	S	L	-	L	S	-	-	-	S	S	-	S	M	M
CO2	S	L	-	L	-	-	-	-	S	S	-	S	M	M
CO3	S	S	-	L	-	-	-	-	S	L	-	S	M	M
CO4	S	S	-	L	S	-	-	-	S	L	-	S	M	M

S – Strong M – Medium L – Low

14MT640 DIGITAL SIGNAL PROCESSING

Category	L	T	P	Credit(s)
PC	2	2	0	3

Course Outcomes

On the successful completion of the course, students will be able to

CO1	Differentiate between the various digital signals such as periodic/aperiodic, Energy/Power, Even/Odd, Causal/Non-Causal and systems such as Static/Dynamic, Linear/Non-Linear, Time Variant/Time Invariant, Causal/Non-Causal	Understand
CO2	Describe the process of sampling and the effects of under sampling	Understand
CO3	Compute DFT and IDFT coefficients of a given discrete time sequence using Fast Fourier Transform algorithms.	Apply
CO4	Draw the implementation structure of IIR and FIR systems using block diagram and signal flow graph representation.	Apply

Mapping with Programme Outcomes and Programme Specific Outcomes

Cos	PO1	PO2	PO3	PO4	PO5	PO6	PO7	PO8	PO9	PO10	PO11	PO12	PSO1	PSO2
CO1	M	L	-	-	-	-	-	-	-	-	-	-	L	L
CO2	M	L	-	-	S	-	-	-	S	S	-	-	S	S
CO3	S	M	L	-	M	-	-	-	-	-	-	-	M	M
CO4	S	M	L	-	S	-	-	-	S	S	-	L	S	S

S – Strong M – Medium L – Low

14MT680 DYNAMICS AND CONTROL LAB

Category	L	T	P	Credit(s)
PC	0	0	2	1

Course Outcomes

On the successful completion of the course, students will be able to

CO1	Analyse and predict the dynamic response of rotating systems behaviour such as force, torque, speed and mass.	Apply
CO2	Design and implement PID controller using ZN tuning technique in practical/simulation environment	Apply
CO3	Design Controller based on the specifications by root locus and/or frequency domain analysis	Apply

Mapping with Programme Outcomes and Programme Specific Outcomes

Cos	PO1	PO2	PO3	PO4	PO5	PO6	PO7	PO8	PO9	PO10	PO11	PO12	PSO1	PSO2
CO1	S	M	L	-	S	M	-	-	S	M	M	S	S	S
CO2	S	M	L	-	S	M	-	-	S	M	M	S	M	L
CO3	S	M	L	-	S	-	-	-	S	M	L	S	L	-

S – Strong M – Medium L – Low

14MT690 ROBOTICS LABORATORY

Category	L	T	P	Credit(s)
PC	0	0	2	1

Course Outcomes

On the successful completion of the course, students will be able to

CO1	Implement the programming and control of robots	Apply
CO2	Predict the Path and trajectory planning for given environment	Apply

Mapping with Programme Outcomes and Programme Specific Outcomes

Cos	PO1	PO2	PO3	PO4	PO5	PO6	PO7	PO8	PO9	PO10	PO11	PO12	PSO1	PSO2
CO1	S	M	L		S	S	M	L	M	M	L	S	M	M
CO2	S	M	L		S	S	M	L	M	M	S	S	S	M

S – Strong M – Medium L – Low

14MT710 PROJECT MANAGEMENT

Category	L	T	P	Credit(s)
HSS	3	0	0	3

Course Outcomes

On the successful completion of the course, students will be able to

CO1	Understand the importance of project management and the role of a project Manager.	Understand
CO2	Identify the critical path in scheduling a set of project-activities by using the Activity-On-Node method.	Apply
CO3	Optimize resources of projects using scheduling, fast tracking and re-estimation techniques	Apply
CO4	Understand the importance and various activities performed for resource management, Outsourcing, risk assessment and project closure.	Understand
CO5	Apply the agile techniques for the project Management.	Understand

Mapping with Programme Outcomes and Programme Specific Outcomes

Cos	PO1	PO2	PO3	PO4	PO5	PO6	PO7	PO8	PO9	PO10	PO11	PO12	PSO1	PSO2
CO1	M	L	-	-	-	-	-	-	-	M	M	L	-	-
CO2	S	M	L	-	-	-	-	-	M	-	S	-	-	-
CO3	S	M	L	-	-	-	-	-	M	-	S	-	-	-
CO4	M	L	-	-	-	-	-	-	-	M	S	-	-	-
CO5	M	L	-	-	-	-	-	-	M	-	S	M	-	-

S – Strong M – Medium L – Low

14MT720 UNMANNED AERIAL VEHICLE

Category	L	T	P	Credit(s)
PC	3	0	0	3

Course Outcomes

On the successful completion of the course, students will be able to

CO1	Explain components and parts, fundamentals of aerodynamics	Remember
CO2	Describe static stability and control	Understand
CO3	Describe and derive flight dynamics and equation of motion	Understand
CO4	Derive Quadrotor kinematics, dynamics and control equations	Apply

Mapping with Programme Outcomes and Programme Specific Outcomes

Cos	PO1	PO2	PO3	PO4	PO5	PO6	PO7	PO8	PO9	PO10	PO11	PO12	PSO1	PSO2
CO1	L	-	-	-	-	-	-	-	-	-	-	-	L	L
CO2	M	L	-	-	-	-	-	-	-	-	-	-	L	L
CO3	M	L	-	-	-	-	-	-	-	M	-	-	M	M
CO4	S	M	L	-	-	-	-	-	-	M	-	-	S	S

S – Strong M – Medium L – Low

14MT770 SYSTEM INTEGRATION

Category	L	T	P	Credit(s)
PC	3	0	2	4

Course Outcomes

On the successful completion of the course, students will be able to

CO1	Describe the characteristics and function of sensors, actuators and controllers.	Remember
CO2	Interface sensor, actuator and controller with suitable driver.	Understand
CO3	Select a suitable sensor and actuator for Mechatronics system integration	Apply
CO4	Develop a controller program to integrate all Mechatronics components using communication network.	Apply

Mapping with Programme Outcomes and Programme Specific Outcomes

Cos	PO1	PO2	PO3	PO4	PO5	PO6	PO7	PO8	PO9	PO10	PO11	PO12	PSO1	PSO2
CO1	L	-	-	-	-	-	-	-	-	-	-	-	-	-
CO2	M	L	-	-	-	-	-	-	-	-	-	-	-	-
CO3	S	M	L	-	-	L	L	L	M	M	M	L	M	M
CO4	S	M	L	-	S	L	L	L	M	M	M	L	M	M

S – Strong M – Medium L – Low

14MT7C0**CAPSTONE COURSEII**

Category	L	T	P	Credit(s)
PC	0	0	4	2

Course Outcomes

On the successful completion of the course, students will be able to

CO1	Explain the basic concepts of core engineering courses in the programme	Understand
CO2	Solve complex problems in core engineering courses of the programme	Apply
CO3	Identify and formulate a complex engineering problem	Analyze
CO4	Develop solution methodology for the chosen engineering problem	Analyze
CO5	Provide solution for the chosen engineering problem	Analyze
CO6	Analyze the performance of the proposed methodology and prepare a technical report	Analyze

Mapping with Programme Outcomes and Programme Specific Outcomes

Cos	PO1	PO2	PO3	PO4	PO5	PO6	PO7	PO8	PO9	PO10	PO11	PO12	PSO1	PSO2
CO1	M	L	-	-	-	-	-	-	-	-	-	S	L	-
CO2	S	M	L	-	-	S	-	-	M	M	-	S	L	L
CO3	S	S	M	L	L	S	M	S	M	M	L	S	S	M
CO4	S	S	M	L	L	M	M	S	S	M	L	S	S	M
CO5	S	S	M	L	S		S	S	S	M	L	S	S	M
CO6	S	S	M	L	S	S	S	S	S	S	M	S	S	M

S – Strong

M – Medium

L – Low

14MTPA0**MACHINE VISION SYSTEM**

Category	L	T	P	Credit(s)
PE	3	0	0	3

Course Outcomes

On the successful completion of the course, students will be able to

CO1	Explain the components of a machine vision system and their functions	Understand
CO2	Select the appropriate sensor and illumination techniques of machine vision system for the given manufacturing application	Apply
CO3	Select suitable image processing technique for the specified manufacturing requirement	Apply
CO4	Select suitable components of machine vision system for the given manufacturing applications such as part identification, counting, measurement and gauging	Apply

Mapping with Programme Outcomes and Programme Specific Outcomes

Cos	PO1	PO2	PO3	PO4	PO5	PO6	PO7	PO8	PO9	PO10	PO11	PO12	PSO1	PSO2
CO1	M	L	-	-	-	-	-	-	-	-	-	-	L	L
CO2	S	M	L	-	-	-	-	-	-	-	-	-	L	L
CO3	S	M	L	-	S	-	-	-	S	S	-	-	S	S
CO4	S	M	L	-	S	-	-	-	S	S	-	-	S	S

S – Strong

M – Medium

L – Low

14MTPB0 MICRO ELECTRO MECHANICAL SYSTEMS Category L T P Credit(s)
PE 3 0 0 3

Course Outcomes

On the successful completion of the course, students will be able to

CO1	Explain the working principles of MEMS and Microsystems	Understand
CO2	Solve problems in scaling laws applicable to miniaturization.	Apply
CO3	Explain Materials for MEMS and Microsystems	Understand
CO4	Select micro-system fabrication and Micro-manufacturing process for a given application	Apply
CO5	Explain the packaging aspects of Micro System	Understand

Mapping with Programme Outcomes and Programme Specific Outcomes

Cos	PO1	PO2	PO3	PO4	PO5	PO6	PO7	PO8	PO9	PO10	PO11	PO12	PSO1	PSO2
CO1	M	L	-	-	-	-	-	-	L	L	-	L	M	L
CO2	S	M	L	L	-	-	-	-	L	L	-	L	M	-
CO3	M	L	-	-	-	-	-	-	L	L	-	L	S	M
CO4	S	M	L	L	-	-	-	-	L	L	-	L	-	M
CO5	M	L	-	-	-	-	-	-	L	L	-	L	M	-

S – Strong M – Medium L – Low

14MTPC0 ADDITIVE MANUFACTURING Category L T P Credit(s)
PE 3 0 0 3

Course Outcomes

On the successful completion of the course, students will be able to

CO1	Explain the concepts of prototypes and AM process chain	Understand
CO2	Select the suitable AM process for a given product/part drawing.	Apply
CO3	Explain rapid tooling methods for Additive Manufacturing	Apply

Mapping with Programme Outcomes and Programme Specific Outcomes

Cos	PO1	PO2	PO3	PO4	PO5	PO6	PO7	PO8	PO9	PO10	PO11	PO12	PSO1	PSO2
CO1	S	L	-	-	M	-	-	-	M	-	L	-	M	L
CO2	S	M	-	-	M	-	-	-	S	-	S	-	M	L
CO3	S	M	-	-	M	-	-	-	S	-	S	-	M	L

S – Strong M – Medium L – Low

14MTPD0 INTEGRATED PRODUCT DEVELOPMENT

Category	L	T	P	Credit(s)
PE	3	0	0	3

Course Outcomes

On the successful completion of the course, students will be able to

CO1	Explain Concept of product development, Sustenance Engineering and End of life Product development in Industry versus Academia, Trade-offs, Intellectual Property Rights and Confidentiality	Understand
CO2	Classify the Product Development methodologies.	Understand
CO3	Perform the PESTLE Analysis and Requirement Engineering Analysis.	Apply
CO4	Develop System Integration, Testing, Certification and Documentation.	Apply
CO5	Identify the specific product development process for a given industry.	Apply
CO6	Transform customer needs into technical specification of a product.	Apply

Mapping with Programme Outcomes and Programme Specific Outcomes

Cos	PO1	PO2	PO3	PO4	PO5	PO6	PO7	PO8	PO9	PO10	PO11	PO12	PSO1	PSO2
CO1	M	L	-	-	L	S	S	L	S	M	S	M	M	M
CO2	M	L	-	-	L	S	S	L	S	S	S	M	S	L
CO3	S	M	L	-	L	S	M	M	S	S	M	M	L	M
CO4	S	M	L	-	L	S	M	S	S	S	S	S	L	L
CO5	S	M	L	-	L	S	M	L	S	M	M	M	M	L
CO6	S	M	L	-	L	S	S	L	S	S	S	M	S	M

S – Strong

M – Medium

L – Low

14MTPE0**VERILOG HDL**

Category	L	T	P	Credit(s)
PE	3	0	0	3

Course Outcomes

On the successful completion of the course, students will be able to

CO1	Introduce VERILOG programming and design concepts for combinational and sequential circuits	Remember
CO2	list and describe various programmable logical devices	Understand
CO3	Design and demonstrate the working of various arithmetic operations using VERILOG	Apply
CO4	Illustrate the state machine design concepts used in digital design of various circuits	Apply

Mapping with Programme Outcomes and Programme Specific Outcomes

Cos	PO1	PO2	PO3	PO4	PO5	PO6	PO7	PO8	PO9	PO10	PO11	PO12	PSO1	PSO2
CO1	L			-	-	-	-	-	-	-	L	-	L	-
CO2	M	L		-	-	M	-	L	-	-	-	-	L	M
CO3	S	M	L	-	-	M	-	L	-	-	-	-	M	S
CO4	S	M	L	-	-	-	-	-	L	-	L	-	M	S

S – Strong

M – Medium

L – Low

14MTPG0 SMART MATERIALS FOR MECHATRONICS

Category	L	T	P	Credit(s)
PE	3	0	0	3

Course Outcomes

On the successful completion of the course, students will be able to

CO1	Understand the basic mechanisms of Smart Materials	Remember
CO2	Select the Smart Materials for Magneto-Thermo-Mechanical Applications	Understand
CO3	Investigate the parameters used in strain measurements	Apply
CO4	Analyse the Smart Materials based micro sensors and micro actuators	Apply
CO5	Review the newly discovered smart materials	Understand

Mapping with Programme Outcomes and Programme Specific Outcomes

Cos	PO1	PO2	PO3	PO4	PO5	PO6	PO7	PO8	PO9	PO10	PO11	PO12	PSO1	PSO2
CO1	L	-	-	-	-	-	-	-	-	-	-	-	L	-
CO2	M	L	-	-	-	-	-	-	-	-	-	-	M	-
CO3	S	M	L	-	-	-	-	-	-	-	-	-	M	L
CO4	S	M	L	-	-	-	-	-	-	-	-	S	S	M
CO5	M	L	-	-	-	-	-	-	-	-	-	S	L	-

S – Strong M – Medium L – Low

14MTPH0**EMBEDDED SYSTEM**

Category	L	T	P	Credit(s)
PE	3	0	0	3

Course Outcomes

On the successful completion of the course, students will be able to

CO1	List and describe the RISC and CISC architecture	Understand
CO2	Distinguish between feature of ARM7 and cortex microcontroller	Understand
CO3	Illustrate the effectiveness of programming model in cortex M	Apply
CO4	Develop efficient coding for multiple interrupt handling	Apply
CO5	Design a control electronic system for industrial automation	Apply
CO6	Develop an embedded system for data acquisition and monitoring	Apply

Mapping with Programme Outcomes and Programme Specific Outcomes

Cos	PO1	PO2	PO3	PO4	PO5	PO6	PO7	PO8	PO9	PO10	PO11	PO12	PSO1	PSO2
CO1	S	M	L	-	-	-	-	-	-	-	-	-	-	-
CO2	S	M	L	-	-	-	-	-	-	-	-	-	-	-
CO3	S	M	M	-	M	-	-	-	M	-	-	M	-	-
CO4	S	M	M	-	M	-	-	-	M	-	-	M	-	-
CO5	S	M	M	-	M	-	-	-	M	-	-	M	S	S
CO6	S	S	S	-	M	-	-	-	M	-	-	M	S	S

S – Strong M – Medium L – Low

14MTPK0 INDUSTRIAL INTERNET OF THINGS

Category	L	T	P	Credit(s)
PE	3	0	0	3

Course Outcomes

On the successful completion of the course, students will be able to

CO1	Explain various technology used in IIOT and its applications	Understand
CO2	Discuss different protocols used in IOT	Understand
CO3	Design a Industrial Internet system	Apply
CO4	Develop a Industry 4.0 Smart factories	Apply

Mapping with Programme Outcomes and Programme Specific Outcomes

Cos	PO1	PO2	PO3	PO4	PO5	PO6	PO7	PO8	PO9	PO10	PO11	PO12	PSO1	PSO2
CO1	M	L	-	-	-	-	-	-	-	-	-	-	L	-
CO2	M	L	-	-	M	L	-	-	-	-	-	L	L	-
CO3	S	M	L	-	-	L	-	-	-	-	-	-	M	L
CO4	S	M	L		M	L	-	-	-	-	-	M	M	L

S – Strong M – Medium L – Low

14MTPM0 INDUSTRIAL COMMUNICATION NETWORKS

Category	L	T	P	Credit(s)
PE	3	0	0	3

Course Outcomes

On the successful completion of the course, students will be able to

CO1	Explain the operation, characteristics and performance of different data networks	Understand
CO2	Identify different cables, connectors and network connecting devices available in the market for data communication.	Understand
CO3	Discuss development of different communication protocols in industries for interconnecting automation systems.	Understand
CO4	Choose appropriate communication network for given industrial applications.	Apply

Mapping with Programme Outcomes and Programme Specific Outcomes

Cos	PO1	PO2	PO3	PO4	PO5	PO6	PO7	PO8	PO9	PO10	PO11	PO12	PSO1	PSO2
CO1	M	L	-	-	-	-	-	M	M	-	-	S	L	-
CO2	M	L	-	-	-	-	-	M	S	S	M	S	L	-
CO3	M	L	-	-	M	M	S	S	S	S	M	S	M	L
CO4	S	M	L	-	M	M	S	S	S	S	M	S	L	M

S – Strong M – Medium L – Low

14MTPN0 AUTOMOTIVE MECHATRONICS

Category	L	T	P	Credit(s)
PE	3	0	0	3

Course Outcomes

On the successful completion of the course, students will be able to

CO1	Identify basic automotive mechatronic systems	Understand
CO2	Explain transmission control, Cruise Control and Engine control system dynamics.	Understand
CO3	Illustrate braking control Traction Control and Suspension Control dynamics.	Apply
CO4	Solve the Stability Control, Steering control dynamics	Apply

Mapping with Programme Outcomes and Programme Specific Outcomes

Cos	PO1	PO2	PO3	PO4	PO5	PO6	PO7	PO8	PO9	PO10	PO11	PO12	PSO1	PSO2
CO1	M	L	-	-	-	-	S	-	-	M	L	S	L	L
CO2	M	L	-	-	-	S	-	-	-	M	L	S	M	L
CO3	S	M	L	-	M	M	-	-	-	L	L	M	M	M
CO4	S	M	L	-	M	S	S	-	-	M	M	M	S	M

S – Strong M – Medium L – Low

14MTPP0 ARTIFICIAL INTELLIGENCE

Category	L	T	P	Credit(s)
PE	3	0	0	3

Course Outcomes

On the successful completion of the course, students will be able to

CO1	Ability to adhere Different AI concepts and its need in problem solving.	Understand
CO2	Learning Fuzzy logic, its orientation to AI and Implementation using python programming language.	Understand
CO3	Illustrate the working of Neural networks and its different learning techniques.	Apply
CO4	Providing solutions using different types of genetic algorithms for optimization and implementation using High level languages.	Apply
CO5	Developing knowledge on different opensource AI tools for using Python programming language	Apply

Mapping with Programme Outcomes and Programme Specific Outcomes

Cos	PO1	PO2	PO3	PO4	PO5	PO6	PO7	PO8	PO9	PO10	PO11	PO12	PSO1	PSO2
CO1	M	L	-	-	-	-	-	-	-	-	-	-	M	-
CO2	M	L	-	-	-	-	M	-	-	M	-	-	M	-
CO3	S	M	L	-	-	-	-	-	-	-	-	-	M	L
CO4	S	M	L	-	M	M	-	M	-	L	-	M	S	L
CO5	S	M	L	-	M	-	-	-	-	-	-	-	S	S

S – Strong M – Medium L – Low

14MTPR0 MECHANICAL AND THERMAL PACKAGING OF ELECTRONICS Category L T P Credit(s)
PE 3 0 0 3

Course Outcomes

On the successful completion of the course, students will be able to

CO1	Calculate Thermal Resistance and surface temperature of electronic component using conductive cooling laws	Apply
CO2	Solve problems related to radiation heat transfer from electronic components	Apply
CO3	Estimate Convection heat transfer requirements for electronic equipment	Apply
CO4	Understand the significance of vibration shock and reliability	Understand

Mapping with Programme Outcomes and Programme Specific Outcomes

Cos	PO1	PO2	PO3	PO4	PO5	PO6	PO7	PO8	PO9	PO10	PO11	PO12	PSO1	PSO2
CO1	S	M	L	-	-	L	-	-	M	-	-	-	M	L
CO2	S	M	L		-	-	-	L	-	-	-	L	M	L
CO3	S	M	L		-	-	-	-	-	L	L	-	M	M
CO4	M	L		-	L	-	L	-	L	L	-	M	L	

S – Strong

M – Medium

L – Low

14MTPT0

DATA ANALYTICS

Category L T P Credit(s)
PE 3 0 0 3

Course Outcomes

On the successful completion of the course, students will be able to

CO1	Identify the big data environment for performing data quality analysis on large data sets.	Apply
CO2	Apply NoSQL data models for unstructured data	Apply
CO3	Perform predictive analytics for text and streaming data	Apply
CO4	Interpret machine learning methods and strategies for data analysis.	Apply

Mapping with Programme Outcomes and Programme Specific Outcomes

Cos	PO1	PO2	PO3	PO4	PO5	PO6	PO7	PO8	PO9	PO10	PO11	PO12	PSO1	PSO2
CO1	S	M	L	-	S	-	S	-	-	-	-	M	M	L
CO2	S	M	L	-	S	-	-	-	-	-	-	M	M	L
CO3	S	M	L	-	S	-	-	S	S	S	-	M	S	M
CO4	S	M	L	-	S	-	-	S	S	S	-	M	S	M

S – Strong

M – Medium

L – Low

14MTPU0**MOBILE ROBOTICS**

Category L T P Credit(s)

PE 3 0 0 3

Course Outcomes

On the successful completion of the course, students will be able to

CO1	Derive the kinematics of various mobile robots	Understand
CO2	Explain the selection and significance of sensor implementation in mobile robots	Understand
CO3	Develop the control architecture for the mobile robot.	Apply
CO4	Implement path planning algorithms according to the environment	Apply

Mapping with Programme Outcomes and Programme Specific Outcomes

Cos	PO1	PO2	PO3	PO4	PO5	PO6	PO7	PO8	PO9	PO10	PO11	PO12	PSO1	PSO2
CO1	M	L	-	-	-	-	L	-	-	M	S	L	L	-
CO2	M	L	-	-	-	-	-	-	-	M	S	L	L	-
CO3	S	M	L	-	M	-	-	-	-	S	S	M	M	L
CO4	S	M	L	-	S	-	M	-	-	S	S	S	M	M

S – Strong

M – Medium

L – Low

14MTPW0**VIRTUAL INSTRUMENTATION**

Category L T P Credit(s)

PE 3 0 0 3

Course Outcomes

On the successful completion of the course, students will be able to

CO1	Define the terminologies and concepts used in virtual instrumentation	Remember
CO2	Will write graphical programs effectively.	Apply
CO3	Discuss in detail about ADC, DAC and Plug in boards used in Virtual Instrument	Understand
CO4	Choose appropriate Architecture/Template for realizing a given application	Apply
CO5	Develop virtual instrument programs for realizing Mechatronic Application	Apply

Mapping with Programme Outcomes and Programme Specific Outcomes

Cos	PO1	PO2	PO3	PO4	PO5	PO6	PO7	PO8	PO9	PO10	PO11	PO12	PSO1	PSO2
CO1	L	-	-	-	S	-	-	-	-	-	L	-	L	-
CO2	S	M	L	-	S	-	-	-	-	-	M	-	L	L
CO3	M	L	-	-	M	-	-	-	-	-	L	-	M	-
CO4	S	M	L	-	S	-	-	-	-	-	L	-	M	L
CO5	S	M	L	-	S	-	-	-	-	-	M	-	M	-

S – Strong

M – Medium

L – Low

14MTPY0 DESIGN OF MACHINE ELEMENTS

Category	L	T	P	Credit(s)
PE	3	0	0	3

Course Outcomes

On the successful completion of the course, students will be able to

CO1	Explain the design concepts of static and fatigue strength of mechanical components.	Understand
CO2	Design the shafts, rigid and flexible couplings parametrically for different loading conditions.	Apply
CO3	Design a suitable flat belt, V-belt, chain drive and spur gear for specified loading condition	Apply
CO4	Design a rolling contact bearing and sliding contact bearing for given power transmission application.	Apply
CO5	Determine the efficiency of a power screw and the amount of load to be raised & lowered.	Apply

Mapping with Programme Outcomes and Programme Specific Outcomes

Cos	PO1	PO2	PO3	PO4	PO5	PO6	PO7	PO8	PO9	PO10	PO11	PO12	PSO1	PSO2
CO1	M	L	-	-	-	-	-	-	-	-	-	-	L	-
CO2	S	M	L	-	-	-	-	-	-	-	-	-	M	L
CO3	S	M	L	-	-	-	-	-	-	-	-	M	M	M
CO4	S	M	L	-	-	-	-	-	-	-	-	M	M	M
CO5	S	M	L	-	-	M	M	-	-	-	-	M	S	M

S – Strong

M – Medium

L – Low

14MT2C0 MUSICAL PARAMETERS AND MIDI

Category	L	T	P	Credit(s)
PEES	2	0	0	2

Preamble

MIDI is a technical standard that describes a communications protocol, digital interface, and electrical connectors that connect a wide variety of electronic musical instruments, computers, and a wide variety of mechanical applications like MIDI controlled fountain, and other similar applications. An introduction to the musical parameters and MIDI, will help to acquire a basic knowledge of MIDI, a gateway to explore new entrepreneur and career options. Also, MIDI related interdisciplinary research will prove to be added advantage for those planning for R & D related career options.

Prerequisite

- Nil

Course Outcomes

On the successful completion of the course, students will be able to

CO1	Explain the basic concepts of the sound parameters and musical parameters	Understand
CO2	Explain the Basic concepts of MIDI Hardware MIDI Data & MIDI signals transmission	Understand
CO3	Demonstrate the computer keyboard input to MIDI synthesiser for music composing	Apply
CO4	Demonstrate the MIDI signal transmission using Laptop., MIDI synthesizer and MIDI cable	Apply
CO5	Explain the MIDI Application & MIDI controlled water fountain	Understand

Mapping with Programme Outcomes and Programme Specific Outcomes

Cos	PO1	PO2	PO3	PO4	PO5	PO6	PO7	PO8	PO9	PO10	PO11	PO12
CO1	-	-	-	-	-	-	-	-	-	-	-	S
CO2	-	-	-	-	-	-	-	-	-	-	-	S
CO3	-	-	-	-	S	-	-	-	S	-	-	S
CO4	-	-	-	-	S	-	-	-	S	-	-	S
CO5	-	-	-	-	-	-	-	-	-	-	-	S

S – Strong

M – Medium

L – Low

Assessment Pattern

Assessment	Marks
Internal Assessment (Music Composing using MIDI and Laptop / Desktop)	50
Terminal Practical (Music Composing using MIDI and Musical Keyboard)	50

Concept Map

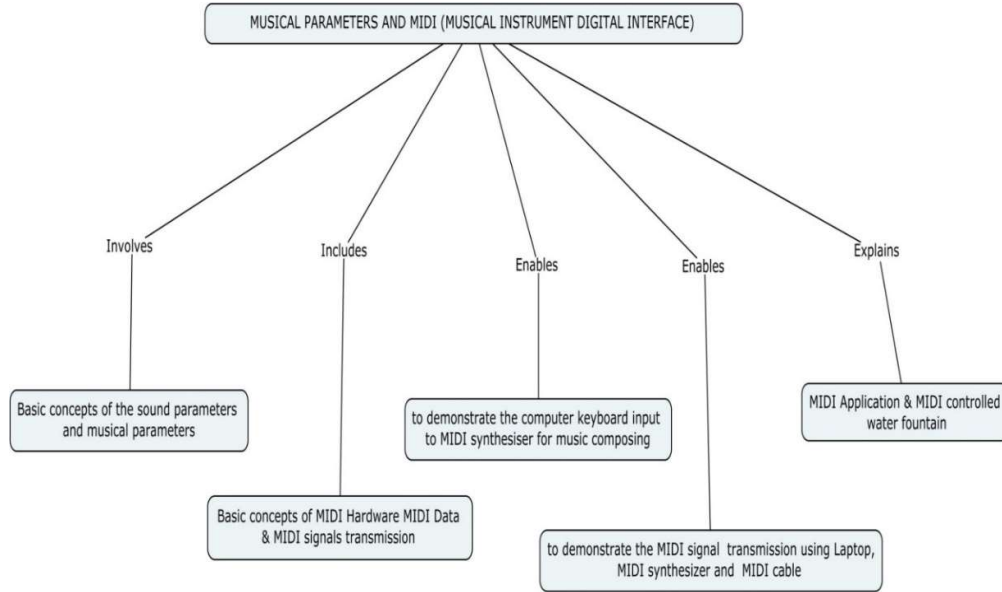

Syllabus

Introduction to Musical Parameters

Basic Acoustic Parameters - Pitch, Intensity and Loudness – Consonance and Dissonance- Resonance – Beats – Harmonic and Non-harmonic Overtones – Timbre- Musical Intervals – Octave, Cycle of Fifth – Cycle of Fourth – Tuning System - Equal Temperament – Just Intonation- Introduction to Western Music Scales related to MIDI

Introduction to MIDI

Introduction to Music related Applications of MIDI – MIDI Hardware- MIDI Port- IN, THRU, OUT- USB -UART chip -Interface- MIDI messages- STATUS byte- DATA byte- MIDI Protocol- MIDI signals Transmission- Standard MIDI Files- Wave to MIDI & MIDI to Wave - MIDI driver program – channels- General MIDI standard- controllers- Daisy Chaining - performance set up - MIDI-sequencing setup - MIDI Applications- MIDI controlled Water Fountain

Learning Resources

1. MIDI Power. The Comprehensive Guide [Paperback]- Robert Guerin - Course Technology CENGAGE learning – 2008
2. A Beginner’s Guide To MIDI: What Is It? How Does It Work? <https://musicianshq.com/a-beginners-guide-to-midi/> & <http://morganstudios.com/Tutorials/MIDI.htm>
3. MIDI Tutorials - <https://www.midi.org/articles-old/tutorials>
4. Modern MIDI by Sam McGuire, Focal Press 2013
5. Music Technology and the Project Studio: Synthesis and Sampling By Dan Hosken
6. https://www.nutsvolts.com/magazine/article/h_2_opus_water_music_lights_and_microcontrollers

Course Contents and Lecture Schedule

Module No.	Topic	No. of Hours	Course Outcome
1	Introduction to Musical Parameters		

1.1	Introduction to MIDI and the significance of Musical Parameters	1	CO1
1.2	Vibration – The Source of Sound – Frequency and its role in pitch and tuning system	1	CO1
1.3	How the sound parameters become the musical parameters	1	CO1
1.4	Important aspects of the Western Music Score view and its significance to MIDI sequencer	1	CO1
1.5	Laptop demonstration of MIDI sequencer - Students hands on training for MIDI input through Laptop keyboard	1	CO3
1.6	Hands on Training to students to understand musical note beats, time signature, in score view and entering the music notes of a simple musical composition	1	CO3
1.7	Equal Temperament - Just Intonation –introduction to other tuning systems	1	CO3
1.8	Pitch and frequency calculation for any kind of world music- Role of beats in Consonance and Dissonance	1	CO3
1.9	Amplitude and its role in loudness - Harmonics and its role in timbre	1	CO3
1.10	Western major and minor scales related to MIDI	1	CO3
1.11	Online down loading of a MIDI file - Score View of the file - writing down the music notes of the file	1	CO3
1.12	Entering the music notes and playing the file – Tips for MIDI music composing	1	CO3
2	Introduction to MIDI		
2.1	Introduction to Music related Applications of MIDI	1	CO5
2.2	MIDI Hardware	1	CO2
2.3	MIDI Port- IN, THRU, OUT- USB	1	CO2
2.4	UART chip –Interface	1	CO2
2.5	MIDI messages- STATUS byte- DATA byte	2	CO2
2.6	MIDI Protocol- MIDI signals Transmission- Standard MIDI Files	1	CO3
2.7	MIDI driver program – channels	1	CO3
2.8	General MIDI standard- controllers- Daisy Chaining - performance set up - MIDI-sequencing setup	1	CO4
2.9	Protocol- MIDI signals Transmission	1	CO4
2.10	Standard MIDI Files, MIDI Applications-Wave to MIDI & MIDI to Wave	1	CO4
2.11	MIDI controlled Water Fountain – Discussion	1	CO5
TOTAL		24	

Course Designers:

Sl. No.	Name	E-mail Id
1	Dr.S.A.Veerapandian	pannpandi@yahoo.co.in
2	Dr. G.Kumaraguruparan	gkgmech@tce.edu